

United Space Alliance (USA)

---

# Solid Rocket Booster Illustrated Systems Manual

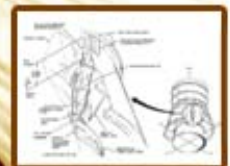
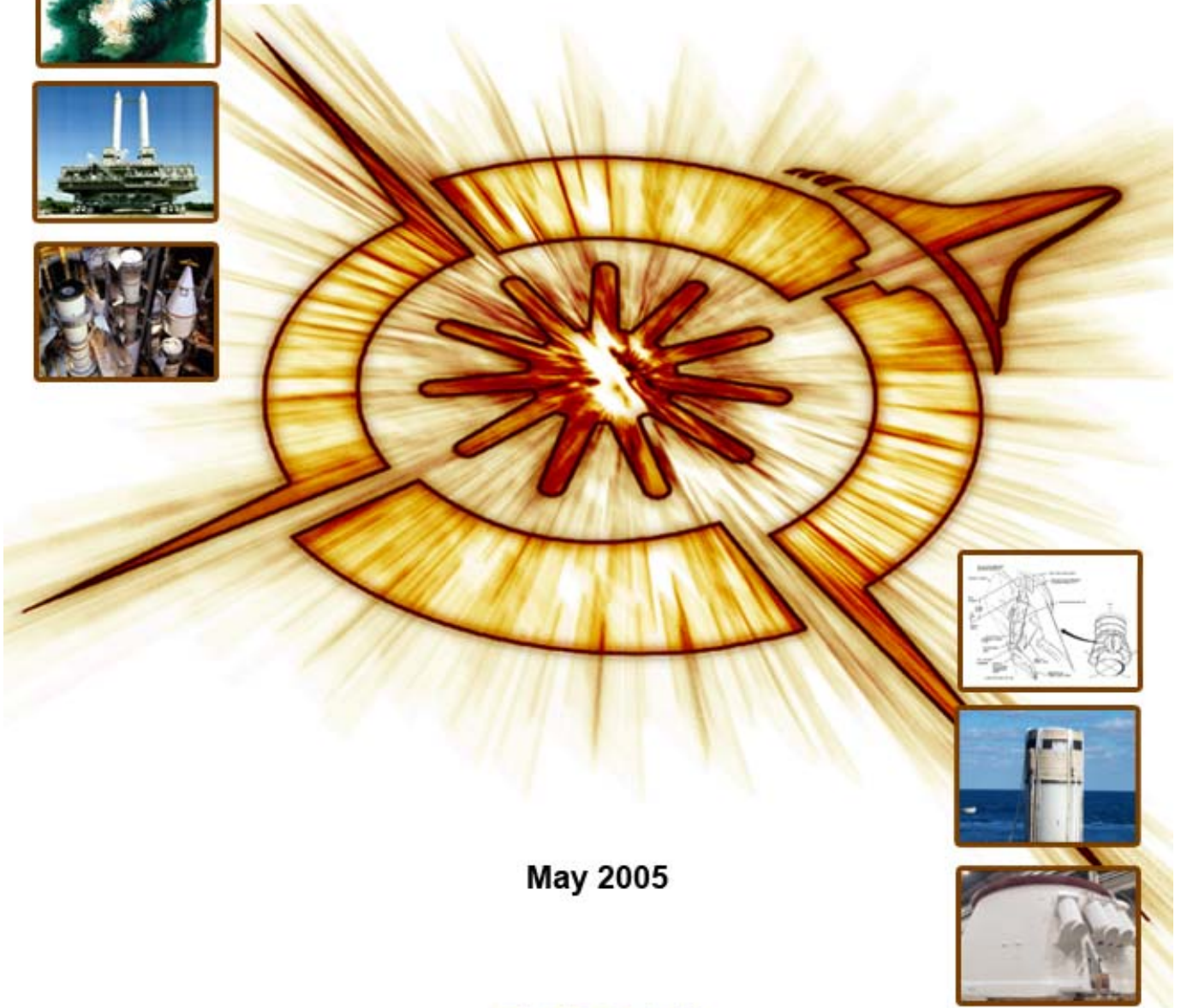

May 2005

**[This page intentionally left blank.]**

**SRB Illustrated Systems Manual  
10PMC-0001**

**Prepared by**

---

**Charles E. Martin  
Sr. Propulsion Engineer  
USA**

### REVISION LOG

<b>Rev. letter</b>	<b>Change no.</b>	<b>Description</b>	<b>Date</b>
Basic 2.0		Initial Release Graphics presentation updates from MSFC	06/08/2005 06/28/2005

## PREFACE

This document was authored and illustrated by Charles E. Martin at ERC, Inc., Huntsville, AL, and released by United Space Alliance. Final document layout was performed for USA by Kyle Simmons. For questions regarding this publication, please contact Charles E. Martin (USA-HSV) at 256-544-5424.

The SRB Illustrated Systems manual was prepared by the United Space Alliance (USA), in cooperation with ERC, Incorporated, as a special study from the NASA SRB Project Office at Marshall Space Flight Center (MSFC), Alabama. This document is to be used as a reference tool for training and visualization purposes. This document is not sufficient as verification of engineering or design data.

The primary responsibility is with the USA SRB Element Program Management Office, 03/64400. Updates and revisions to this document will be implemented upon request from the NASA SRB Project Office at MSFC. Requests for update shall be submitted to the Special Studies and Strategic Development office of USA SRB Element, 03/64460.

This document has an accompanying CD-ROM entitled the Multimedia Illustrated Handbook. This multimedia CD-ROM contains all the text and illustrations found in this document, and allows users to search, view, copy and paste text and images directly to other documents.

To request additional copies of the CD-ROM, contact Kyle Simmons (Technical Publications, Sr.) at 321/867-2558, USK-873, 03/64410.

## TABLE OF CONTENTS

ABBREVIATIONS AND ACRONYMS .....	xiii
1.0 SCOPE .....	1
1.1 Purpose. ....	1
1.2 SRB Configuration Description.....	1
1.3 Drawings.....	1
2.0 APPLICABLE DOCUMENTS .....	7
2.1 Specifications.....	7
2.2 Other Publications. ....	7
2.3 Other Documents - National Aeronautics and Space Administration.....	7
3.0 STRUCTURAL SUBSYSTEM.....	10
3.1 General.....	10
3.2 Nose CAP Assembly AND Frustum .....	10
3.3 Forward Separation Ring.....	11
3.4 Forward Skirt .....	11
3.5 Forward Attach Fitting .....	12
3.6 Aft ET Attach Ring.....	12
3.7 SRB/ET Aft Attach Struts .....	12
3.8 Systems Tunnel.....	12
3.9 Aft Skirt .....	13
3.10 SRB Thermal Protection Subsystem (TPS).....	13
4.0 ELECTRICAL AND INSTRUMENTATION SUBSYSTEM .....	30
4.1 General.....	30
4.2 E&I Subsystem Description. ....	31
4.3 E&I Subsystem Functions .....	32
4.3.1 Prelaunch Functions.....	32
4.3.2 Ascent Phase Functions. ....	32
4.3.2.1 E&I Components Active During the Boost Flight Phase .....	32
4.3.2.2 Functions Controlled or Monitored by the Orbiter through the E& I Subsystem .....	32
4.3.3 SRB Recovery Functions.....	32
4.3.3.1 E&I Subsystem Components Active During the Recovery Phase .....	33
4.3.3.2 Sequence of Events Controlled by the E&I Subsystem During SRB Recovery. ....	33
4.3.4 Data Acquisition System (DAS).....	33
4.4 Aft IEA Physical Description, .....	33
4.5 Aft IEA Functional Description.....	34
4.5.1 Distributor Function.....	34
4.5.1.1 PICs.....	34
4.5.1.2 Switching Cards.....	35
4.5.1.3 EMI Filters.....	35
4.5.1.4 Miscellaneous Component Boards. ....	35
4.5.1.5 APU Controller Assemblies. ....	35
4.5.1.6 Harnesses. ....	36
4.5.1.7 Data Bus Coupler.....	36
4.5.1.8 BITE .....	36
4.5.2 Multiplexer/Demultiplexer (MDM) Function. ....	36
4.5.2.1 MDM. ....	36
4.5.3 Signal Conditioner Functions. ....	37

4.5.3.1	PBISs.....	37
4.5.3.2	ABAs.....	37
4.5.3.3	CPDs.....	37
4.5.3.4	CVRDs.....	37
4.5.3.5	Calibration Cards.....	37
4.5.3.6	Harness Assemblies.....	37
4.5.4	Pressure Transducer.....	38
4.6	Forward IEA Physical Description.....	38
4.7	Forward IEA Functional Description.....	38
4.7.1	Distributor Function.....	38
4.7.1.1	PICs.....	38
4.7.1.2	Switching Cards.....	38
4.7.1.3	EMI Filters.....	38
4.7.1.4	Miscellaneous Component Boards.....	38
4.7.1.5	Recovery Logic.....	38
4.7.1.6	Current Shunt.....	38
4.7.1.7	Harness Assemblies.....	39
4.7.2	MDM Function.....	39
4.7.3	Signal Conditioner Functions.....	39
4.7.4	Pressure Transducer.....	39
4.8	Rate Gyro Assembly (RGA).....	39
4.9	Instrumentation Sensors.....	39
4.10	Altitude Switch Assembly.....	39
4.11	Cable Assemblies and Circuits.....	39
4.12	Subsystem Redundancy.....	40
4.13	Instrumentation and Signal Conditioners.....	40
4.13.1	Wideband Signal Conditioner (WBSC) Unit.....	40
4.13.2	Dedicated Signal Conditioner.....	41
4.13.3	Pressure Sensors.....	41
4.13.4	Temperature Sensors.....	41
4.13.5	Current Sensors.....	41
4.13.6	Voltage Sensors.....	41
4.13.7	Camera Subsystem.....	42
5.0	SOLID ROCKET BOOSTER THRUST VECTOR CONTROL SUBSYSTEM.....	54
5.1	General Description.....	54
5.2	TVC Subsystem Operational Sequence.....	55
5.3	Contingency Modes.....	56
5.3.1	110 Percent Operation.....	56
5.3.2	112 Percent Operation.....	57
5.4	Gimbal Capability.....	57
5.5	TVC Component Descriptions.....	57
5.5.1	Fuel Supply Module (FSM).....	58
5.5.2	Fuel Filter.....	58
5.5.3	Single Mission Fuel Isolation Valve (SMFIV).....	58
5.5.4	Auxiliary Power Unit (APU).....	58
5.5.5	Gearbox Pressure Equalization Device (GPED).....	58
5.5.6	Hydraulic Pump.....	58
5.5.7	Hydraulic Bootstrap Reservoir.....	59

5.5.8	Hydraulic Fluid Manifold.....	59
5.5.9	APU Controller.....	59
5.5.10	Hydraulic Fluid Check Valve and Filter.....	60
5.5.11	Hydraulic Pressure Block.....	60
5.5.12	Subsystem Service Panels.....	60
5.5.13	Accumulator.....	60
5.5.14	Servoactuators.....	60
6.0	SEPARATION SUBSYSTEM.....	99
6.1	General.....	99
6.2	SRB Separation Sequence.....	99
6.3	Attachments Release.....	99
6.3.1	Electrical Disconnects.....	100
6.3.2	Separation Bolts.....	100
6.4	BSM General.....	100
6.4.1	BSM Case.....	101
6.4.2	BSM Nozzle/Aft Closure Assembly.....	101
6.4.3	BSM Propellant.....	102
6.4.4	BSM Case Liner.....	102
6.4.5	BSM Igniter.....	102
6.4.6	BSM Covers.....	102
6.4.7	BSM Ignition.....	102
6.4.8	BSM Thermal Protection.....	102
7.0	SOLID ROCKET BOOSTER RECOVERY SUBSYSTEM.....	114
7.1	General Description.....	114
7.2	Recovery Subsystem Operational Sequence.....	115
7.2.1	Separation and Recovery Initialization.....	115
7.2.2	Nose Cap Jettison.....	115
7.2.3	Pilot Parachute Deployment.....	116
7.2.4	Drogue Parachute Deployment.....	116
7.2.5	Frustum Separation.....	116
7.2.6	Main Parachute Deployment.....	117
7.2.7	Nozzle Extension Jettison.....	117
7.2.8	SRB Water Impact.....	117
7.3	Recovery Subsystem Components.....	118
7.3.1	Pilot Parachute Pack Assembly.....	118
7.3.2	Drogue Parachute Pack Assembly.....	118
7.3.3	Drogue-Pilot Assembly.....	118
7.3.4	Main Parachute Pack Assembly.....	119
7.3.5	Main Parachute Cluster Assembly.....	119
7.3.6	Recovery Electronics and Instrumentation.....	119
7.4	At-Sea Retrieval Operations.....	119
8.0	RANGE SAFETY SUBSYSTEM.....	141
8.1	General.....	141
8.2	RSS Control Interfaces.....	142
8.2.1	LPS Command Control.....	142
8.2.2	In-flight Commands.....	142
8.3	Destruct Subsystem Description.....	142
8.3.1	RSS ARM Sequence.....	143



8.3.2	RSS FIRE Sequence.....	143
8.4	RSD Assembly Interfaces Functions.....	144
8.4.1	Interface Between the GSE and the S&A Device.....	144
8.4.2	Inhibit/Reset.....	144
8.4.3	RSS Power Supply.....	144
8.4.4	S&A Device ARM & SAFE.....	144
8.5	RSS Ground Transmission.....	145
8.6	RSS Ordnance Subsystem Description.....	145
8.6.1	SRB RSS Ordnance.....	145
8.7	RSS Activation Sequence.....	145
8.8	Solid Rocket Booster Tracking System (SRBTS).....	146
8.8.1	SRBTS Operational Description.....	146
8.8.2	SRBTS Components.....	146
8.8.3	SRBTS Functional Description.....	147
9.0	SOLID ROCKET MOTOR.....	154
9.1	General.....	154
9.2	SRM Integrated Ignition Sequence of Operation.....	154
9.3	SRM Case.....	155
9.3.1	Forward Segment.....	155
9.3.2	Cylindrical Segment.....	156
9.3.3	SRB/ET Attachment Segment.....	156
9.3.4	Case Stiffener Segment.....	156
9.3.5	Aft Dome.....	156
9.3.6	Stiffener Ring.....	156
9.4	Propellant.....	156
9.4.1	Propellant Formulation.....	156
9.4.2	Composition.....	156
9.4.3	Properties.....	157
9.4.4	Grain Design.....	157
9.5	Insulation and Liner.....	158
9.5.1	Insulation.....	158
9.5.1.1	Forward Casting Segment.....	158
9.5.1.2	Center Casting Segments.....	158
9.5.1.3	Aft Casting Segment.....	158
9.5.2	Liner.....	159
9.6	Nozzle.....	159
9.6.1	Cowl Assembly.....	159
9.6.2	Nose/Inlet Assembly.....	159
9.6.3	Throat/Inlet Assembly.....	160
9.6.4	Exit Cone Assembly, Forward.....	160
9.6.5	Exit Cone Assembly, Aft.....	160
9.6.6	SRM Nozzle Plug.....	160
9.6.7	Fixed Housing Assembly.....	160
9.6.8	Flexible Bearing Boot.....	161
9.6.9	Passive Snubber Assembly.....	161
9.7	Flexible Bearing Assembly.....	161
9.8	Ignition Subsystem Components.....	161
9.9	Ignition Design Characteristics.....	161

9.9.1	Igniter Adapter.....	162
9.9.2	Igniter Initiator.....	162
9.9.3	Rocket Motor Igniter .....	162
9.9.4	S&A Device.....	163

## LIST OF ILLUSTRATIONS

Figure 1-1. Composite Space Shuttle and Mobile Launch Platform .....	2
Figure 1-2. Solid Rocket Boosters and Space Transportation System on Mobile Launch Platform .....	2
Figure 1-3. Solid Rocket Booster (SRB) .....	3
Figure 1-4. SRB Component Drawing .....	3
Figure 1-5. SRB Basic Assembly and Orientation to MLP and ET .....	4
Figure 1-6. SRB Orientation to Space Shuttle on the MLP .....	4
Figure 1-7. Space Transportation System and SRB Orientation .....	5
Figure 1-8. SRB Systems .....	6
Figure 3-1. Nose Cap Assembly Exterior and View showing Separation Thrusters .....	10
Figure 3-2. Nose Cap and Frustum Assembly .....	11
Figure 3-3. SRB Forward Separation Ring Cross Section .....	11
Figure 3-4. SRB Forward Skirt Showing Details .....	14
Figure 3-5. SRB Forward Assembly (Nose Cap, Frustum, Forward Skirt) .....	15
Figure 3-6. Right SRB/ET Forward Attach and RSS Crossover .....	15
Figure 3-7. Right SRB/ET Forward Attach and SRB Cable Routing .....	16
Figure 3-8. SRB E&I Hardware Locations (Fwd Skirt) .....	16
Figure 3-9. SRB/ET Forward RH Attach Fitting .....	16
Figure 3-10a. SRB/ET Component View and Picture of Forward Attach Thrust Post .....	17
Figure 3-10b. Forward Attach Bolt Catcher (cutaway) .....	17
Figure 3-11a. External Tank Attach Ring Structure Overview (Insulation Omitted for Clarity) .....	17
Figure 3-11b. ETA Ring Strut Connections .....	18
Figure 3-11c. ETA Ring Segments Structure .....	18
Figure 3-11d. ETA Ring Splice Plates and Joints Configuration .....	18
Figure 3-12. External Tank Attach Ring Showing System Tunnel and IEA Cover .....	18
Figure 3-13. External Tank Attach Ring Showing Connection Struts .....	19
Figure 3-14. External Tank Attach Ring Showing Pre and Post Separation Strut Condition. ....	19
Figure 3-15a. SRB/ETA Ring Structure .....	20
Figure 3-15b. SRB/ETA Struts Orientation to Flight Configuration .....	20
Figure 3-16. SRB/ET Attach Strut Lower and Diagonal .....	21
Figure 3-17. SRB/ET Lower And Diagonal Attach Strut Expanded View .....	21
Figure 3-18. SRB/ET Upper Strut Assembly .....	21
Figure 3-19. SRB/ET Upper Attach Strut Expanded View .....	22
Figure 3-20. Upper Strut Cable Pass-through Connections .....	22
Figure 3-21. Systems Tunnel Configuration .....	23
Figure 3-22. Systems Tunnel Configuration Section Details .....	23
Figure 3-23. SRB Systems Tunnel Floor Geometry and Layout .....	24
Figure 3-24. Systems Tunnel on RSRM .....	25
Figure 3-25. Systems Tunnel Configuration Fwd & Aft Connections (Canoe and Rooster Tail) .....	25
Figure 3-26. SRB Aft Skirt Detail (SRM Nozzle not shown for Clarity) .....	26
Figure 3-27. SRB Holddown Connection Components at MLP .....	26
Figure 3-28. SRB Holddown Section and Components .....	27
Figure 3-29a. SRB Holddown Views .....	27
Figure 3-29b. SRB Holddown Stud showing Frangible Nut and NSI Cabling .....	28
Figure 3-30. SRB Aft Skirt/SRM Case Attach Detail .....	28
Figure 3-31. SRB Aft Skirt Thermal Curtain Configuration .....	29
Figure 3-32. SRB Thermal Protection Subsystem General Configuration .....	29

Figure 4-1. Forward and Aft IEA Locations within SRB Hardware.....	30
Figure 4-2. Forward and Aft IEA Locations Relative to SRB Assembly. ....	30
Figure 4-3. Typical IEA Assembly Components .....	42
Figure 4-4. IEA Component Locations and Description.....	43
Figure 4-5. IEA Components Showing Current Flight Configuration. ....	46
Figure 4-6. IEA Connector Arrangement for Forward and Aft Assemblies .....	46
Figure 4-7. IEA Aft Connector Images (typical).....	47
Figure 4-8. Integrated Electronics Assembly (IEA) Water Impact Sensors.....	47
Figure 4-9. Electrical and Instrumentation (E&I) Subsystem Functional Diagram .....	48
Figure 4-10. PIC Simplified Schematic.....	48
Figure 4-11. SRB TVC APU Controller .....	49
Figure 4-12. SRB MDM Connectors.....	49
Figure 4-13. SRB MDM Component Pictures .....	50
Figure 4-14. SRM Chamber Pressure Transducer.....	51
Figure 4-15. Rate Gyroscope Assemblies (Right Hand) .....	51
Figure 4-16. IEA/MDM Code Plug.....	52
Figure 4-17. SRB Data Acquisition System.....	52
Figure 4-18. SRB Data Acquisition System.....	53
Figure 5-1. SRB Tilt Thrust Vector Control Subsystem in Aft Skirt.....	62
Figure 5-2. SRB Thrust Vector Control Subsystem in Aft Skirt.....	62
Figure 5-3. SRB As Installed in Aft Skirt .....	63
Figure 5-4. TVC Schematic Views.....	63
Figure 5-5. TVC Access Ports in Aft Skirt.....	64
Figure 5-6. HPU A/Rock Actuator Hydraulic Control Subsystem .....	64
Figure 5-7. Fuel Supply Module Schematic views.....	65
Figure 5-8. Fuel Supply Module Components and Installed in TVC Framework .....	65
Figure 5-9. Fuel Isolation Valve Isometric Views .....	65
Figure 5-10. Fuel Isolation Valve Cutaway.....	66
Figure 5-11. Auxiliary Power Unit Detail Orthogonal View 1 .....	66
Figure 5-12. Auxiliary Power Unit Detail Orthogonal View 2 .....	67
Figure 5-13. Auxiliary Power Unit Cutaway Views .....	67
Figure 5-14. APU :Mounting Axes and Mounts .....	68
Figure 5-15. Gas Generator Valve Module .....	68
Figure 5-16. Gas Generator Valve Module Cutaway .....	68
Figure 5-17. APU Gas Generator View 1.....	69
Figure 5-18. APU Gas Generator View 2.....	69
Figure 5-19. APU Turbine Wheel & Balance Assembly .....	70
Figure 5-20. APU Turbine Wheel and Shaft .....	70
Figure 5-21. APU Turbine Wheel & Balance Assembly Cutaway .....	71
Figure 5-22. APU Turbine Wheel & Balance Assembly Expanded View.....	71
Figure 5-23. APU and Hydraulic Pump Assembly .....	72
Figure 5-24. TVC Hydraulic Pump Envelope.....	72
Figure 5-25. Hydraulic Pump Sectional View.....	73
Figure 5-26. TVC Hydraulic Pump Piston Barrel Assembly .....	73
Figure 5-27. Hydraulic Pump Depressurizing System & Pump Compensator Operation .....	74
Figure 5-28. Hydraulic Pump Compensating Mechanism .....	75
Figure 5-29. TVC Hydraulic Bootstrap Reservoir .....	75
Figure 5-30. Hydraulic Bootstrap Reservoir Connection Hardware .....	76

Figure 5-31. TVC Bootstrap Reservoir Expanded View.....	76
Figure 5-32. TVC Bootstrap Reservoir Operational Schematic.....	77
Figure 5-33. TVC Hydraulic Fluid Manifold.....	77
Figure 5-34. TVC Hydraulic Fluid Manifold Schematic and Envelope.....	78
Figure 5-35. TVC Hydraulic Fluid Manifold Sectional Views.....	78
Figure 5-36. TVC Hydraulic Fluid Manifold Port Description.....	79
Figure 5-37. TVC Hydraulic Fluid Manifold Installation.....	79
Figure 5-38. High Pressure Relief Valve.....	80
Figure 5-39. Low Pressure Relief Valve.....	80
Figure 5-40. TVC Hydraulic Check Valve and Filter Assembly (CVFA).....	81
Figure 5-41. Hydraulic CVFA Schematic.....	81
Figure 5-42. TVC Service Panels and Location.....	82
Figure 5-43. SRB TVC Quick Disconnect.....	82
Figure 5-44. SRB TVC Manual Shutoff Valve Assembly.....	83
Figure 5-45. SRB TVC Manual Shutoff Valve Assembly (Expanded View).....	83
Figure 5-46. TVC Hydraulic Accumulator-Piston Type.....	84
Figure 5-47. TVC Hydraulic Accumulator-Bellows Type.....	84
Figure 5-48. TVC Hydraulic Accumulator-Types Installation.....	85
Figure 5-49. SRB TVC Lube Oil Accumulator (Bellows Type).....	85
Figure 5-50. TVC Servoactuator Location.....	86
Figure 5-51. Section View of Servovalve Assembly.....	86
Figure 5-52. Servovalve Schematic (1 of 2).....	87
Figure 5-53. Servovalve Schematic (2 of 2).....	88
Figure 5-54. Power Valve Assembly.....	89
Figure 5-55. Dynamic Pressure Feedback (DPF) Assembly.....	89
Figure 5-56. Solenoid Isolation Valve Assembly.....	90
Figure 5-57. Differential Pressure Transducer.....	90
Figure 5-58. Lock Valve Assembly.....	91
Figure 5-59. Power Valve And Feedback Configuration.....	91
Figure 5-60. APU Functional Schematic.....	92
Figure 5-61. Electro-Hydraulic Servoactuator.....	93
Figure 5-62. Simplified Schematic Of Thrust Vector Control Servoactuator Pressure Loop.....	94
Figure 5-63. Thrust Vector Control Servoactuator Schematic.....	94
Figure 5-64. SRB Thrust Vector Control Actuator Polarity.....	95
Figure 5-65. SRB TVC Subsystem Schematic.....	95
Figure 5-66. SRB TVC Controls and Measurement.....	96
Figure 5-67. SRB APU Controls and Measurements (Rock A).....	96
Figure 5-68. Hydrazine Control Subsystem.....	97
Figure 5-69. SRB TVC Actuator Schematic and Components.....	98
Figure 6-1. SRB Separation Sequence.....	103
Figure 6-2. BSM Ignition and SRB Structural Release Subsystem.....	103
Figure 6-3. SRB/ET Forward (RH) Attach Fitting Exploded view.....	104
Figure 6-4. SRB/ET Upper Attach Bolt Separation Plane.....	104
Figure 6-5. SRB/ET Fwd Attach & Separation Interfaces.....	105
Figure 6-6. Forward SRB/ET Separation Bolt.....	105
Figure 6-7. SRB/ET Lower and Diagonal Attach Strut Expanded View.....	106
Figure 6-8. SRB/ET Upper Attach Strut Exploded View.....	106
Figure 6-9. Aft Separation Bolt Assembly.....	107

Figure 6-10. Forward Booster Separation Motors Schematic .....	107
Figure 6-11. Forward Booster Separation Motors Pictures Showing Covers .....	108
Figure 6-12. Forward BSM Details and CDF Manifold.....	108
Figure 6-13. Forward BSM Ignition CDF Manifold .....	108
Figure 6-14. SRB AFT BSM Orientation on Aft Skirt.....	109
Figure 6-15. AFT BSM Alternate Configuration Showing Covers.....	109
Figure 6-16. AFT BSM Details .....	110
Figure 6-17. Aft BSM Cluster Showing Insulated and Non-Insulated Configuration .....	110
Figure 6-18a. SRB BSM Section View .....	111
Figure 6-18b. SRB BSM Showing Igniter Re-design .....	111
Figure 6-18c. BSM Nozzle and Throat Cutaway .....	112
Figure 6-19. Forward BSM Nozzle Cover .....	112
Figure 6-20. AFT Booster Separation Motors Heat Seal Configuration.....	113
Figure 7-1. SRB Operational Profile launch to splashdown .....	121
Figure 7-2. Altitude Switch Assembly .....	122
Figure 7-3. SRB Altitude Sensing Subsystem & Forward Main Parachute Support Structure.....	122
Figure 7-4. SRB Nose Cap Thruster-Installation .....	123
Figure 7-5. SRB Nose Cap Separation & Pilot Parachute Deployment.....	123
Figure 7-6. Reefing Line Cutter .....	124
Figure 7-7. Second Stage Reefing Line Cutter On Parachute .....	124
Figure 7-8. SRB Frustum/Separation Ring Assembly.....	125
Figure 7-9. SRM Nozzle Linear Shaped Charge Cutoff Device .....	125
Figure 7-10. SRB Post-Splashdown Spar Mode .....	126
Figure 7-11. SRB Frustum Flotation Model With Drogue Attached .....	126
Figure 7-12. Pilot Parachute Canopy Assembly.....	127
Figure 7-13. Pilot Parachute Pack Assembly .....	127
Figure 7-14. Drogue Parachute Details .....	128
Figure 7-15. SRB Drogue Parachute Gore Configuration.....	128
Figure 7-16. Drogue Parachute Pack Assembly .....	129
Figure 7-17. Pilot Pack connected to Drogue Parachute Pack .....	129
Figure 7-18. Drogue-Pilot Assembly.....	130
Figure 7-19. Drogue-Pilot Assembly Integration .....	130
Figure 7-20. Main Parachutes Deployed .....	131
Figure 7-21a. Main Parachute Details .....	132
Figure 7-22. Main Parachute Pack Assembly .....	133
Figure 7-23. Main Parachute Support Structure .....	133
Figure 7-24. Main Parachute Cluster Assembly and Plenum Chamber .....	134
Figure 7-25. Water Impact Conditions And Post Impact Parachute Placement.....	135
Figure 7-26. SRB Recovery Ship .....	136
Figure 7-27. SRB Recovery Ambar .....	136
Figure 7-28. SRB Diver Operations .....	137
Figure 7-29. SRB Log Mode Orientation and Waterline .....	137
Figure 7-30 SRB In Log Mode Showing Waterline (EDOP not shown) .....	138
Figure 7-31 Enhanced Diver Operating Plug .....	138
Figure 7-32 SRB in Log Mode Being Towed by Recovery Ship during transit to Slip.....	138
Figure 7-33 SRB and Recovery Ship During Hip Operations.....	139
Figure 7-34 SRB Retrieval Operations at SRB Slip.....	140
Figure 8-1 SRB RSS Functional Diagram.....	148

Figure 8-2. RSS Directional Coupler .....	148
Figure 8-3. RSS Hybrid Coupler .....	149
Figure 8-4. SRB Range Safe and Arm (S&A) Device Section View.....	149
Figure 8-5 Safe and Arm Assembly for RSS .....	150
Figure 8-6 Range Safety Panel No. 1 .....	151
Figure 8-7 Range Safety Subsystem Panel No. 2 Forward Skirt.....	151
Figure 8-8. RSS Integrated Receiver/Decoder (IRD).....	152
Figure 8-9. SRB RSS Ordnance Components .....	152
Figure 8-10. SRB Range Safety Command Destruct Subsystem.....	153
Figure 8-11. RSS Antenna Locations .....	153
Figure 9-1. Solid Rocket Motor Configuration .....	164
Figure 9-2. SRB Ignition Functional Circuits .....	164
Figure 9-3a. SRM Dome Joints .....	165
Figure 9-3b. SRB/SRM Joints.....	165
Figure 9-4a. SRM Field & Factory Joints .....	166
Figure 9-4b. SRM Field & Factory Joints Schematic .....	166
Figure 9-5. SRM Nozzle Assembly showing cutaway and Scale .....	166
Figure 9-6 SRM Forward Nozzle and Aft Exit Cone Assemblies .....	167
Figure 9-7a. SRM Nozzle Showing Actuator Connection and Aft Dome Joint.....	167
Figure 9-7b. SRM Nozzle Aft Dome Joint Schematic .....	168
Figure 9-8. SRM Nozzle Showing Five Joints.....	168
Figure 9-9. SRM Ignition Subsystem S&A Device Orthogonal View.....	168
Figure 9-10. SRM Ignition Subsystem Igniter Device Showing Attach Flange and Details .....	169
Figure 9-11. SRM Ignition S&A and Igniter Housing .....	169
Figure 9-12. SRM Ignition S&A Device Attach Flange .....	170
Figure 9-13. SRM Ignition S&A Device.....	170
Figure 9-14. SRM Forward Case Cross Section Showing Star Pattern, S&A, And Igniter.....	171

LIST OF TABLES

TABLE 4-1. Forward IEA Unit, List of Major Assemblies .....	44
TABLE 4-2. Aft IEA Unit, List of Major Assemblies .....	45
TABLE 4-3. Leading Particulars for IEAs .....	47
TABLE 4-4. Module Complement .....	50
TABLE 5-1. Leading Particulars for APU Driven Hydraulic Pump.....	59
TABLE 7-1 Recovery Subsystem Functional Components .....	118
TABLE 9-1 SRM Propellant Composition.....	157
TABLE 9-2 SRM Propellant Burn Data.....	157
TABLE 9-3 SRM Nozzle Characteristics.....	159



## ABBREVIATIONS AND ACRONYMS

A&M	Actuation and Monitoring
A/D	Analog to Digital
A/R	As Required
ABA	Amplifier Buffer Attenuator
ACA	Altitude Controller Assembly
ACCUM	Accumulator
ACE	Acceptance Checkout Equipment
ACO	Acceptance Checkout
AFETRM	Air--Force--Eastern Test Range Manual
AMP	Ampere
APU	Auxiliary Power Unit
ASA	Altitude Switch Assembly
B-B	Booster-Barrier
BH	Bulkhead
BITE	Built In Test Equipment
BPS	Bits per Second
BSM	Booster Separation Motor
BTA	Booster Trowelable Ablative
BTU	British Thermal Unit
CD	Center Director
CDDT	Countdown Demonstration Test
CDF	Confined Detonating Fuse
CDR	Critical Design Review
CMD	Command
CMD DCDR	Command Decoder
CP	Cylindrical Perforated
CPD	Converter, Pulse to Direct Current Voltage
CTPB	Carboxyl Terminated Polybutadiene
CVRDs	Converter, Variable Resistance, Direct Current Voltage
DAS	Data Acquisition System
DC	Direct Current
DCID	Direct Current Input Differential
DCR	Design Certification Review
DDT&E	Design, Development, Test, and Evaluation
DFI	Developmental Flight Instrumentation
DIA	Diameter
DIH	Discrete Input High, 28 Volts
DIL	Discrete Input Low, 5 Volts
DIR	Directional
DMM	Digital Multimeter
DOD	Department of Defense
DOL	Discrete Output Low, 5 Volts
DPFA	Dynamic Pressure Feedback Assembly
DWG	Drawing
ECA	Epoxy Curing Agent
EDAS	Enhanced DAS reserved for future inclusion
EEPROM	Electrically Erasable Programmable Read Only Memory
E&I	Electrical and Instrumentation
EMI	Electromagnetic Interference
EPDM	Ethylene Propylene Diene Monomer
EQSP	Equally Spaced

ET	External Tank
ETR	Eastern Test Range
°F	Degrees Fahrenheit
FDIR	Fault Detection, Isolation and Recovery
FDM	Frequency Division Multiplexer
FEP	Front End Processor
FH	Flex Hose
FIV	Fuel Isolation Valve
FLT	Flight
FM	Frequency Modulation
FPS	Feet per Second
FRF	Flight Readiness Firing
FSC	Flight Control System
FSM	Fuel Supply Module
ft-lb	foot-pounds
ft-lb-sec	foot-pounds-seconds
FWC	Filament Wound Case
FWD	Forward
GEI	Ground Environmental Instrumentation
GG	Gas Generator
GGVM	Gas Generator Valve Module
GN&C	Guidance, Navigation, and Control
GN2	Gaseous Nitrogen
GPC	General Purpose Computer
GPED	Gearbox Pressure Equalization Device
GPM (gpm)	Gallons Per Minute
gr/ft	Grains per Foot
GSE	Ground Support Equipment
HMX	Cyclotetramethylenetetranitramine
HP	High Pressure
HPM	High Performance Motor
HPRV	High Pressure Relief Valve
HPU	Hydraulic Power Unit
HTPB	Hydroxyl Terminated Polybutadiene
HTR	Heater
ICD	Interface Control Document
ID	Inside Diameter
IEA	Integrated Electronics Assembly
in-lb	inch-pounds
IN STL	Installation
ips	Inches per second
IRD	Integrated Receiver/Decoder
IRIG	Interrange Instrumentation Group
Kbps	Thousand Bits per Second
Klbf	Thousand pound feet
KSC	Kennedy Space Center
LBS	Pounds
LDB	Launch Data Bus
lb-sec	pound-second
LSC	Linear Shaped Charge
LH	Left-hand
LP	Low Pressure

LPRV	Low Pressure Relief Valve
LPS	Launch Processing System
LSRB	Left Solid Rocket Booster
MAX	Maximum
MCIU	Mission Control and Interface Unit
MDM	Multiplexer/Demultiplexer
MEC	Master Events Controller
MET	Mission Elapsed Time
MHz	Megahertz
MIA	Multiplexer Interface Adapter
MIN	Minimum
MLP	Mobile Launch Platform
MPU	Magnetic Pickup
ms	Millisecond
MCC	Marshall Convergent Coating
MSFC	Marshall Space Flight Center
MTR	Motor
N2H4	Hydrazine
NASA	National Aeronautics and Space Administration
NBR	Nitrilebutadiene Rubber
NC	Normally Closed
NO	Normally Open
NO.	Number
NOM	Nominal
NSD	NASA Standard Detonator
NSI	NASA Standard Initiator
NSTS	National Space Transportation System
OD	Outside Diameter
OF	Operational Flight
OV	Orbiter Vehicle
PBAN	Polybutadiene/Acrylic Acid/Acrylonitrile Terpolymer
PBIS	Power Bus Isolation Supplies
PCM	Pulse Code Modulator
PCV	Pulse Control Valve
PETN	Penta Erythrite Tetra Nitrate
PIC	Pyrotechnic Initiator Controller
PRI	Primary
PROM	Programmable Read Only Memory
PSI	Pounds Per Square Inch
PSIA	Pounds Per Square Inch, Absolute
PSID	Pounds Per Square Inch, Differential
PSIG	Pounds Per Square Inch, Gage
PWR	Power
QD	Quick Disconnect
REF	Reference
RF	Radio Frequency
RGA	Rate Gyroscope Assembly
RH	Right-hand
RKT	Rocket
RPM	Revolutions Per Minute
RS	Range Safety
RSD	Range Safety Distribution

RSO	Range Safety Officer
RSRB	Right Solid Rocket Booster
RSS	Range Safety Subsystem
RT455	Thermal Ablative Compound
RTD	Resistance Temperature Device
RTV	Room Temperature Vulcanized
RU	Remote Unit
S&A	Safe and Arm
SCU	Sequence Control Unit
sec	Second
SEP	Separation
SFFS	Spot Face Far Side
SII	SRM Ignition Initiator
SOV	Shutoff Valve
SRB	Solid Rocket Booster
SRM	Solid Rocket Motor
SSME	Space Shuttle Main Engine
STA	Station
STD	Standard
STS	Space Transportation System
STU	Sensor Timer Unit
SW	switch
SWAR	Salt Water Activated Release
SYS	System
TM	Telemetry
TPS	Thermal Protection Subsystem
TVC	Thrust Vector Control
TYP	Typical
VAC	Volts, Alternating Current
VCO	Voltage Controlled Oscillator
VDC	Volts, Direct Current
VHF	Very High Frequency
WBSC	Wideband Signal Conditioner
WTR	Western Test Range
WT	Weight

## 1.0 SCOPE

### 1.1 PURPOSE.

The purpose of this document is to provide the reader with a general description of the Solid Rocket Booster (SRB) and explain how the SRB and Redesigned Solid Rocket Motor (RSRM) are used as an integral element of the Space Shuttle. This document is not intended to be a specification and is for reference only. If this document is transmitted, copied, or duplicated in whole or in part, the statement "For Reference Only" should accompany the data. This document is a combination of previously developed manuals 10MNL-0028 - SRB Pictorial Representations and 10MNL-0029 – SRB Systems Data Book.

### 1.2 SRB CONFIGURATION DESCRIPTION.

The basic elements for the space shuttle are the Orbiter Vehicle (OV), External Tank (ET), and the two recoverable SRBs depicted in Figures 1-1, through 1-4. The SRBs consist of the RSRMs and the system components to provide flight control and monitoring to the RSRM performance. The SRBs also provide the primary shuttle ascent boost with an assist from the three Space Shuttle Main Engines (SSMEs) on the OV. The SRB design is based on twenty-mission usage and incorporates seven major subsystems to meet the requirements definition. These subsystems are described herein:

1. Structural
2. Electrical and Instrumentation
3. Thrust Vector Control
4. Separation
5. Recovery
6. Range Safety
7. Re-useable Solid Rocket Motor

This document will provide illustrative schematics and descriptions of the integrated functional subsystems. It will also provide a physical definition of these subsystems related to system characteristics, capabilities, and mission timeline. The prelaunch, ascent, separation, reentry, and recovery phases of the SRB and its subsystems are defined when warranted.

### 1.3 DRAWINGS.

The descriptive illustrations included herein are derived from several sources and are subject to review and update through those source documents. Any configuration information contained herein is subject to verification.

Unless otherwise noted, the majority of schematics represent the left SRB. The right SRB is basically identical, rotated 180°. Minor differences exist in the electrical and instrumentation (E&I) subsystems, booster separation motor locations, SRB/ET attach ring orientations, and forward skirts, as examples.

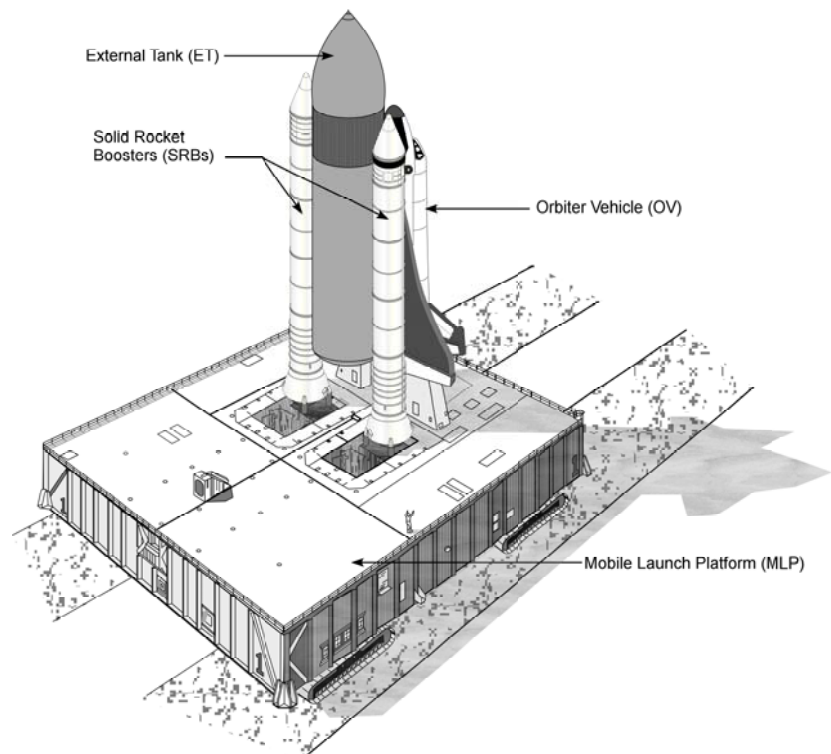

Figure 1-1. Composite Space Shuttle and Mobile Launch Platform



Figure 1-2. Solid Rocket Boosters and Space Transportation System on Mobile Launch Platform

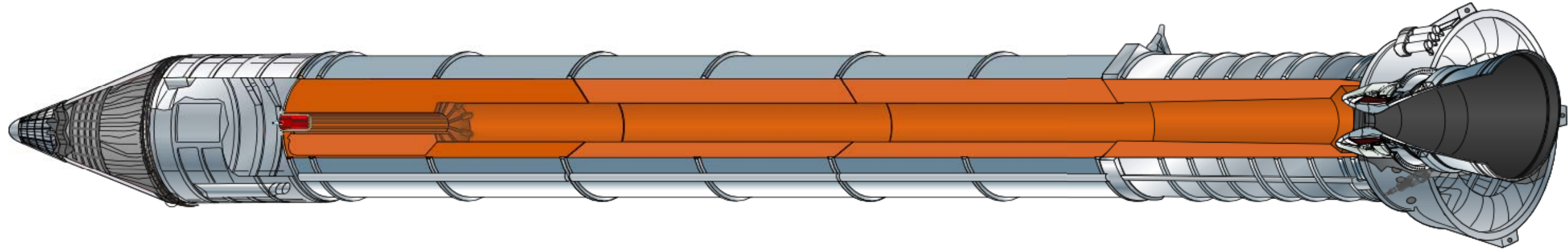

Figure 1-3. Solid Rocket Booster (SRB)

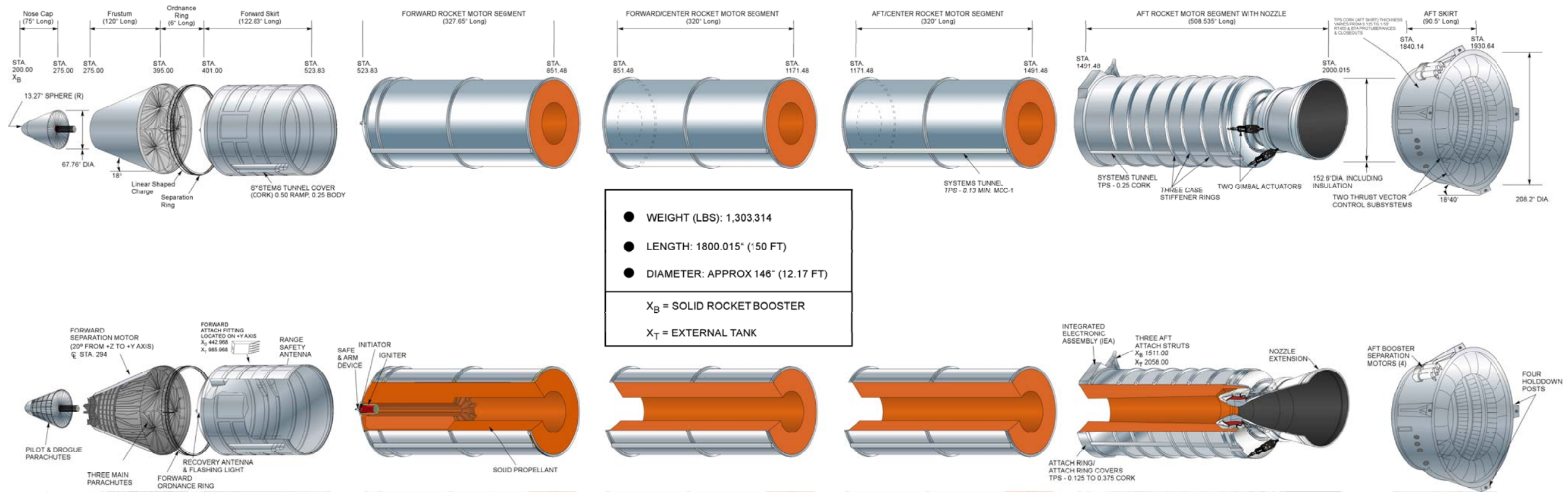

Figure 1-4. SRB Component Drawing

Figures 1-5 and 1-6 shows the basic assembly components for the SRB and its orientation to the External Tank (ET) and MLP. Figure 1-7 illustrates the relationship of the SRBs to the Space shuttle. Figure 1-8 presents the SRB systems as an integrated assembly.

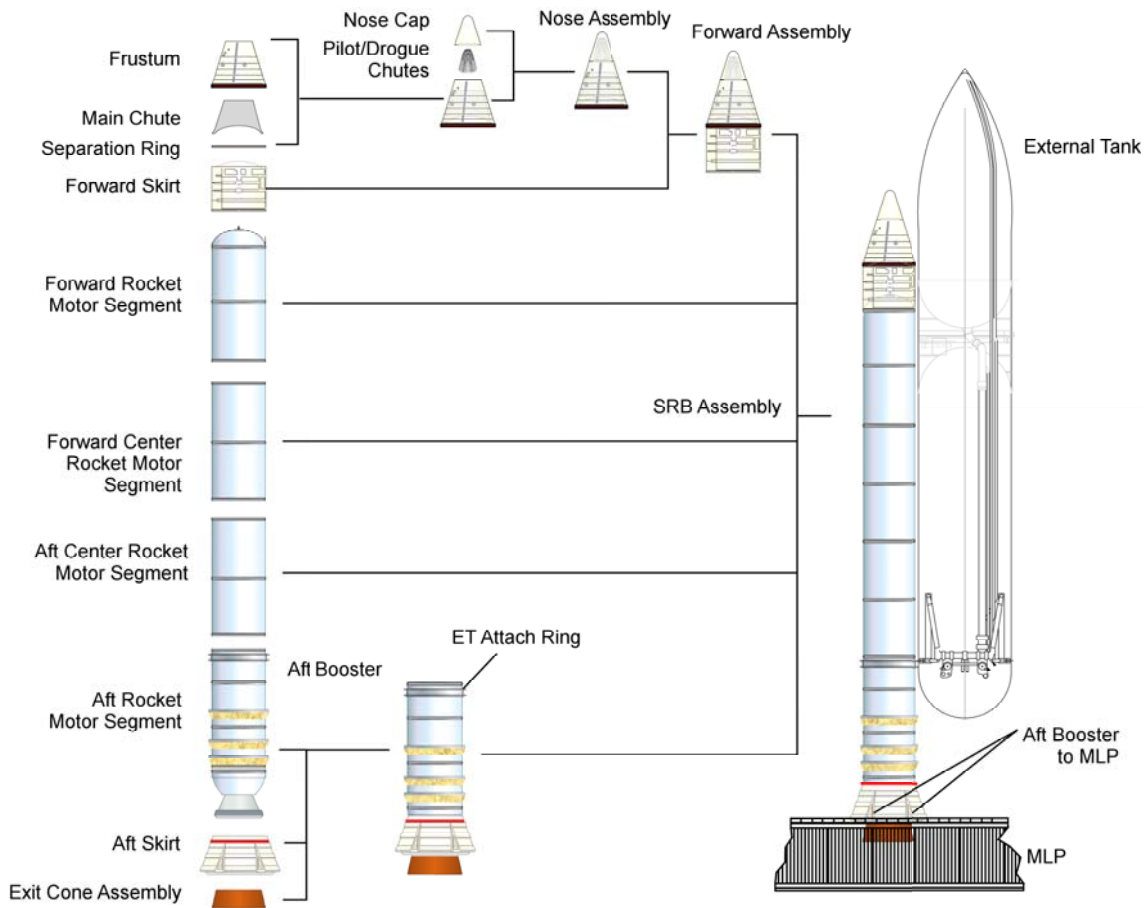

Figure 1-5. SRB Basic Assembly and Orientation to MLP and ET

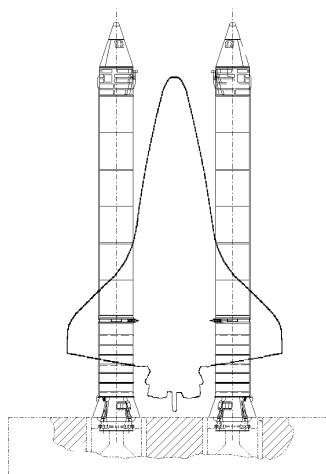

Figure 1-6. SRB Orientation to Space Shuttle on the MLP



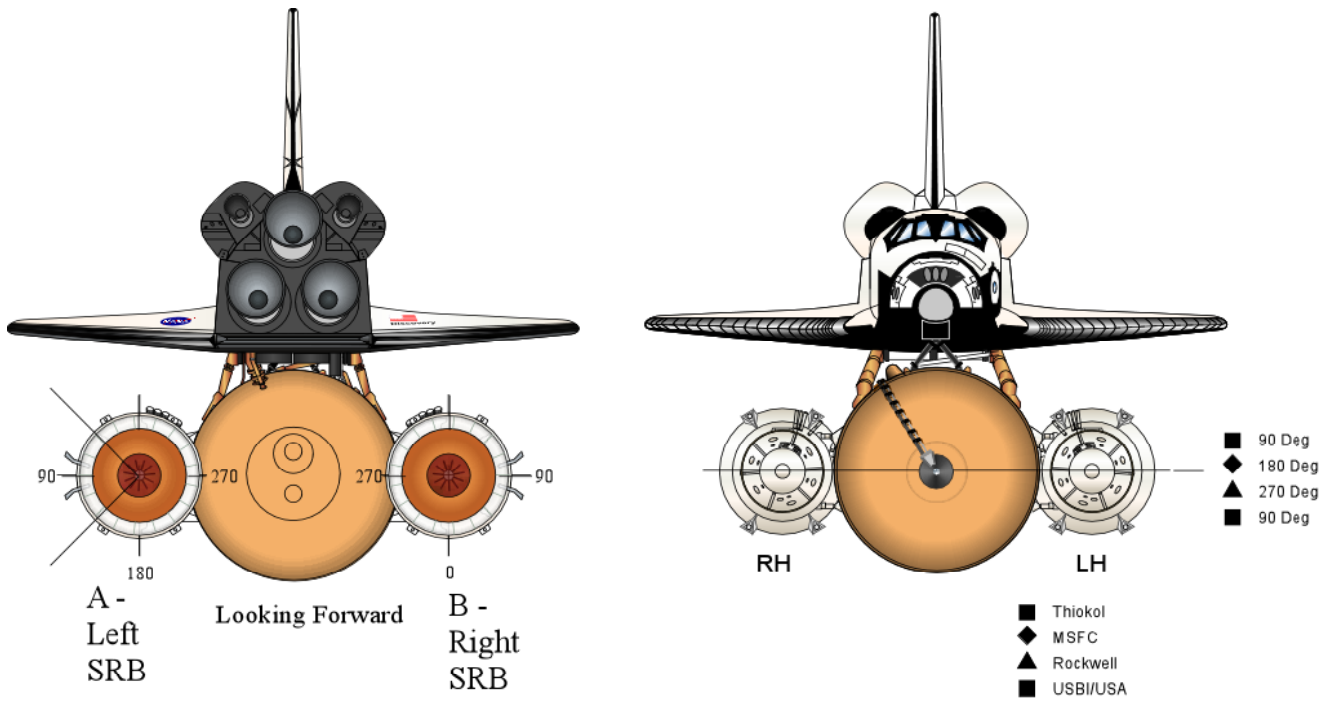

Figure 1-7. Space Transportation System and SRB Orientation

# SRB System Components

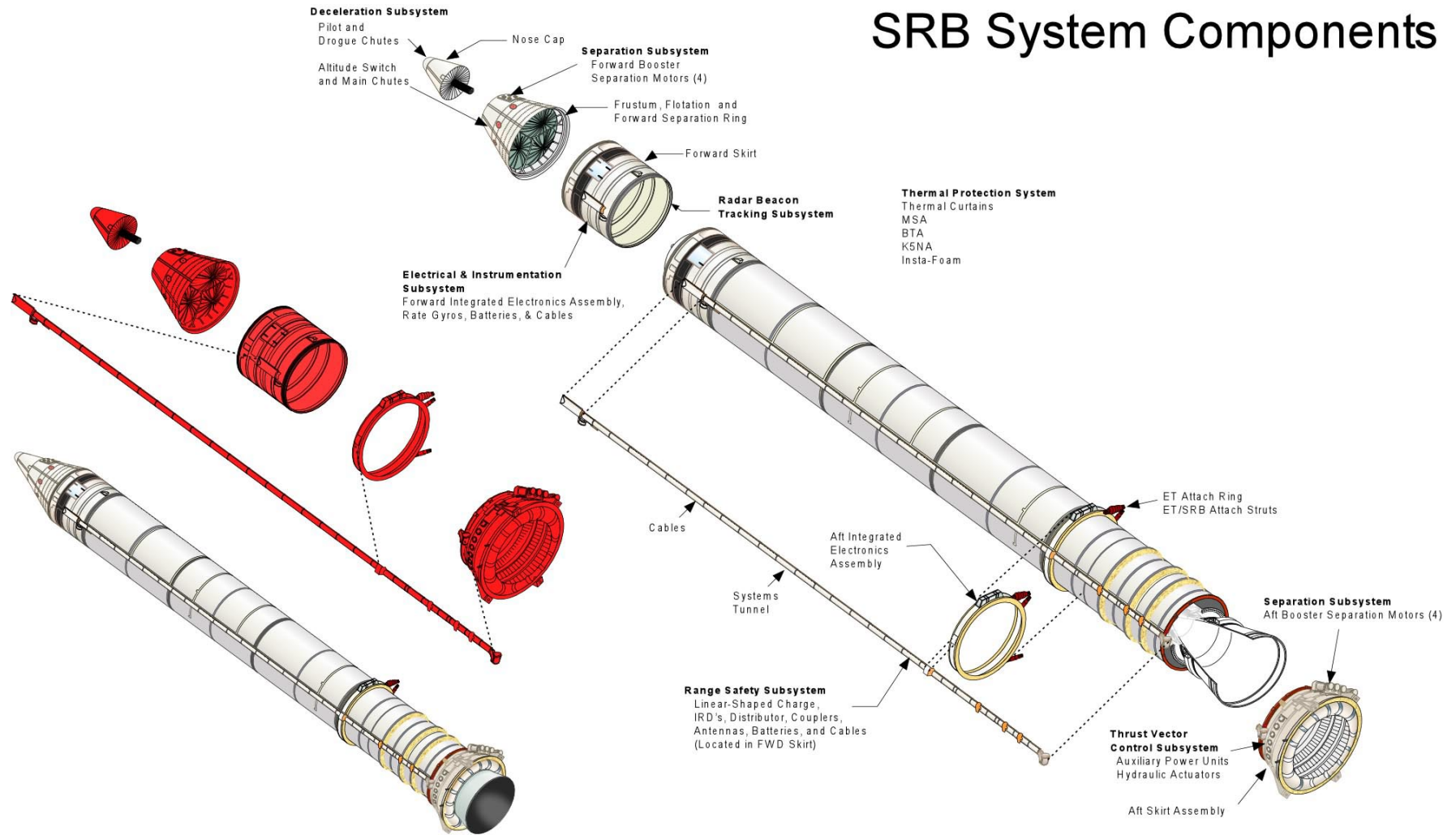

Figure 1-8. SRB Systems

## 2.0 APPLICABLE DOCUMENTS

The following documents may be used for a fuller understanding of the contents of this document.

### 2.1 SPECIFICATIONS

#### National Aeronautics and Space Administration (NASA)

NSTS 07700, Vol.-X- NSTS-08209	Space Shuttle Flight and Ground System Specifications SHUTTLE SYSTEMS DESIGN CRITERIA VOLUME I: SHUTTLE PERFORMANCE ASSESSMENT DATABOOK
--------------------------------------	---

#### Contractor – United Space Alliance, SRB Element.

10CEI-0001	Contract End Item Specification for the Integrated Solid Rocket Booster Operational Flights
------------	--

### 2.2 OTHER PUBLICATIONS.

#### Data Book - National Aeronautics and Space Administration

SE-019-068-2H SE-019-125-2H	SRB Thermal Design Data Book SRB Systems Performance and Design Data
--------------------------------	---

#### Manuals - Military

AFETRM 127-1 SAMTECM 127-1	Range Safety Manual, Volume I, Safety, Air Force Eastern Test Range Manual Range Safety Manual, Volume I, Safety, Range Safety Requirements, Space and Missile Test Center Manual
-------------------------------	---

#### Handbook- National Aeronautics and Space Administration

10A00570	Range Safety Systems Handbook for Space Shuttle SRB/ET
----------	--

### 2.3 OTHER DOCUMENTS - NATIONAL AERONAUTICS AND SPACE ADMINISTRATION

SE-019-090-2H CM-017-016-2H CM-017-017-2H	SRB Mission Events Timeline SRM Interface Control Documents, Contractual Index and Status Report SRB Interface Control Documents, Contractual Index and Status Report
---	---

Contractor – USA (Previous Contractor USBI where Applicable)

10IPL-0003	SRB Instrumentation Program and Component List Thrust Vector Control (TVC)Electronic Notebook
10MNL-0028	SRB Pictorial Representations
10MNL-0029	SRB Subsystems Data Book
10MNL-0045	SRB Subsystem and Component Fact Sheets
10SPC-0027	Specification for Pressure Cartridge NSI Separation System for SS SRB
10SPC-0030	Specification for Frangible Nut SRB/MLP Release System SS SRB
10SPC-0031	Specification for Frangible Nut Booster Cartridge Assembly for SS SRB_MLP Release Subassembly
10SPC-0032	Specification for Initiator Confined Detonating Fuse SS SRB
10SPC-0035	Spec for Assy confined detonation fuse STS
10SPC-0038	Specification for Separation Assembly Frustum Separation SS SRB
10SPC-0039	Command Antenna Model 320 Secure Range Safety Specification
10SPC-0048	Specification for Hydraulic Fluid Check Valve and Filter Assy SRB TVC Sys
10SPC-0049	Specification for Hydrazine Fuel Supply Module SRB TVC Sys
10SPC-0050	Specification for Auxiliary Power Unit SRB TVC Sys
10SPC-0051	Specification for Accumulator and Associated Components SRB TVC Sys
10SPC-0052	Spec for Bootstrap Hyd Reservoir SRB TVC Sys
10SPC-0053	Specification for Hydraulic Pump SRB TVC Sys
10SPC-0054	Spec for Fluid Manifold Assy SRB TVC Sys
10SPC-0057	Specification for Coupling, Quick- Disconnect for the SRB TVC Sys
10SPC-0058	Specification for Auxiliary Power Unit Vibration Isolation System SRB TVC Sys
10SPC-0059	Specification for Altitude Switch Assembly
10SPC-0081	Specification for Manual Shutoff Valve SRB TVC Sys
10SPC-0131	Refurbish Engineering Specifications for SS SRB Assy Project
10SPC-0161	SRB Mechanical Ground Support Equipment (MGSE) Design Requirements Specification
10SPC-0162	SRB Electrical Ground Support Equipment (EGSE) Design Requirements Specification
10SPC-0163	SRB Mechanical Production Support Equipment (PSE) Design Requirements Specification
10SPC-0165	Connectors Electrical Circular Miniature Underwater Specification for
10SPC-0166	Cable Assemblies Watertight Reusable Specification for
10SPC-0169	Reefing Line Cutter, Recovery System SS SRB Specification for
10SPC-0174	Specification for Hydraulic Sampling and Bleed Valve SRB TVC Sys
10SPC-0188	Specification for SRB Decelerator Subsystem
10SPC-0212	Cable Assemblies Non-watertight Reusable Specification for
10SPC-0223	Solid Rocket Booster Separation Subsystem Specification for
10SPC-0226	Silver_Zinc Battery Specification for
10SPC-0227	Nonrefurbished Parts Minor Defect Criteria
10SPC-0228	Electrical Production Support Equipment (PSE) Design Requirements Specification SRB
10SPC-0230	Specification for Range Safety System Safety and Arming Device
10SPC-0231	Specification for Thruster Pressure Cartridge
10SPC-0232	Specification for Shuttle Command Receiver_Decoder
10SPC-0236	Specification for SRB Main Parachute Salt Water Actuated Disconnect Link
10SPC-0239	Lacing Cable Assemblies and Harnesses Specification for
10SPC-0240	Specification for SRB Single Mission FIV
10SPC-0242	Altitude Switch Assembly Contract End Item Design Specification
10SPC-0245	Spec for Reefing Line cutter SRB Recovery
ICD-3-44001	SRM to Forward Skirt
ICD-3-44002	Systems Tunnel
ICD-3-44003	SRM to Aft Skirt and TVC Actuator
ICD-3-44004	SRM to ET Attach Rings
ICD-3-44005	SRM to SRB E&I Subsystem
ICD-3-44010	SRB Retrieval Station

ICD-2-00001	Shuttle Mold protuberances
ICD-2-0a001	Platform and VAB stacking
ICD-2-0a002	Pad and platform
ICD-2-0a003	Computers
ICD-2-0a004	Communication
ICD-2-0d003	Tracking
ICD-2-0d004	RF and Tracking
ICD-2-0h001	Orbiter_ground range
ICD-2-12001	Orbiter_ET
ICD-2-14001	Orbiter_SRB
ICD-2-17001	Orbiter_carrier aircraft
ICD-2-1a001	KSC landing
ICD-2-1a002	OPF and Checkout
ICD-2-1d004	Orbiter_aircraft mate
ICD-2-24001	ET to SRB
ICD-2-2a001	ET Processing
ICD-2-4a001	SRB Processing

DDB TWR 16881      Design Data Book for Space Shuttle Reusable Solid Rocket Motor

### 3.0 STRUCTURAL SUBSYSTEM

#### 3.1 GENERAL.

The SRB structural subsystem provides the necessary structural support for the shuttle vehicle on the launch pad; holds the shuttle vehicle on the launch pad during SSME thrust buildup, vehicle twang, and SRM ignition transient prior to lift-off; transfers thrust loads to the Orbiter and ET; and provides the housing, structural support, and bracketry needed for the recovery subsystem, the range safety subsystem, the electrical components, the separation motors, and the thrust vector control subsystem. The SRB structural subsystems consist of the nose assembly (frustum and nose cap), the forward separation ring, the forward skirt (including the forward SRB/ET attach fitting), the aft SRB/ET attach ring and attach struts, the aft skirt (including the thermal curtain), the systems tunnel, and structures for mounting other SRB subsystem components. In addition, frustum flotation, weighing, hoisting and towing provisions, and structural thermal protection are provided by this subsystem.

#### 3.2 NOSE CAP ASSEMBLY AND FRUSTUM

The nose assembly includes the nose cap assembly and the frustum assembly. The nose cap assembly is shown on Figure 3-1. The nose cap is basically an aluminum structure with a hemispherical section at the forward end. The base is approximately 68 inches in diameter and the overall length is 75 inches. This structure is a riveted assembly consisting of machined 2024 aluminum sheet skins, formed ring segments, machined fittings, formed cap, and a machined frustum separation ring. The nose cap houses both the pilot and drogue parachutes (See Figures 3-1 and 3-2) and is separated from the frustum by three frustum-mounted thrusters. The nose cap thrusters are fired on command to initiate the recovery phase. The nose cap is initially positioned and oriented on the frustum by six frustum mounted alignment pins. These pins serve as guides until sufficient clearance has been attained between the cap and frustum during separation. The frustum structural assembly is composed of six shear beams machined from 2219 aluminum forgings, rings, fittings, separation motor housing, main chute supports, and 7075 aluminum formed skins. The frustum minor base diameter is approximately 68 inches. The height is approximately 10 feet. The major base is 146 inches in diameter. The frustum houses the main parachutes, the altitude sensor and the forward separation motors, and incorporates flotation devices for water recovery. The nose cap is not typically recovered.

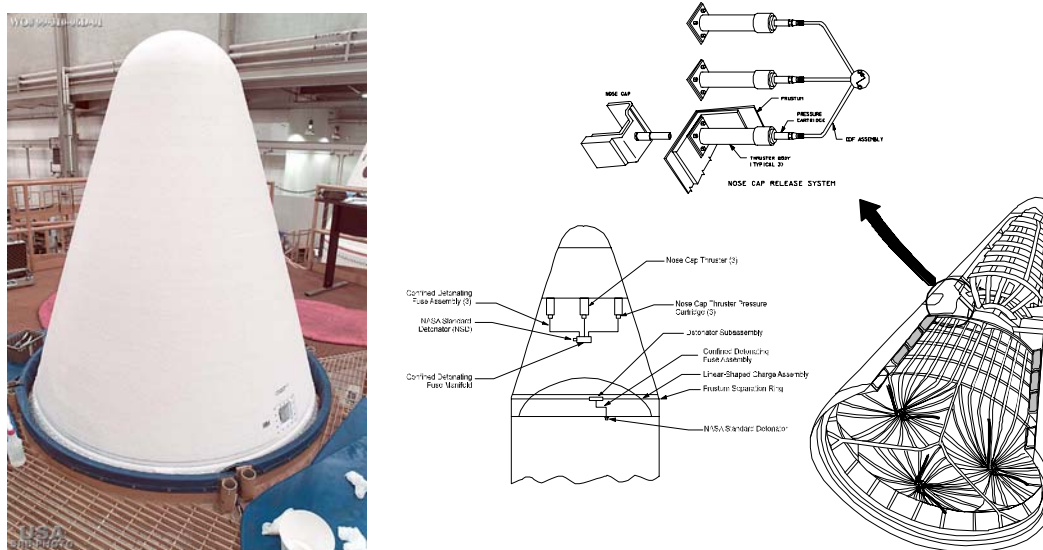

Figure 3-1. Nose Cap Assembly Exterior and View showing Separation Thrusters

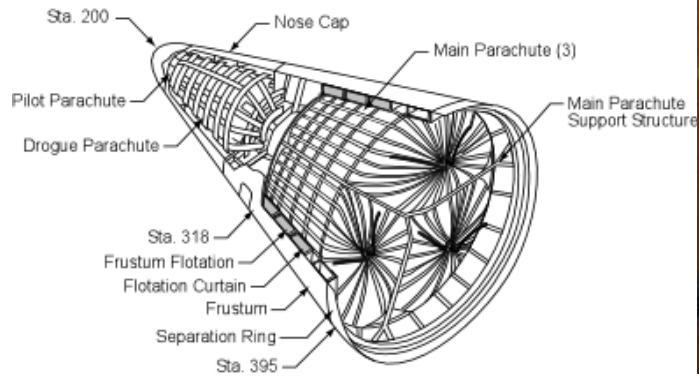

Figure 3-2. Nose Cap and Frustum Assembly

### 3.3 FORWARD SEPARATION RING

The forward separation ring provides a plane of separation between the frustum and forward skirt assemblies. The ring is machined from a 2219 aluminum forging and provides mounting provisions for the linear shaped charge used in the severance function as shown in Figure 3-3.

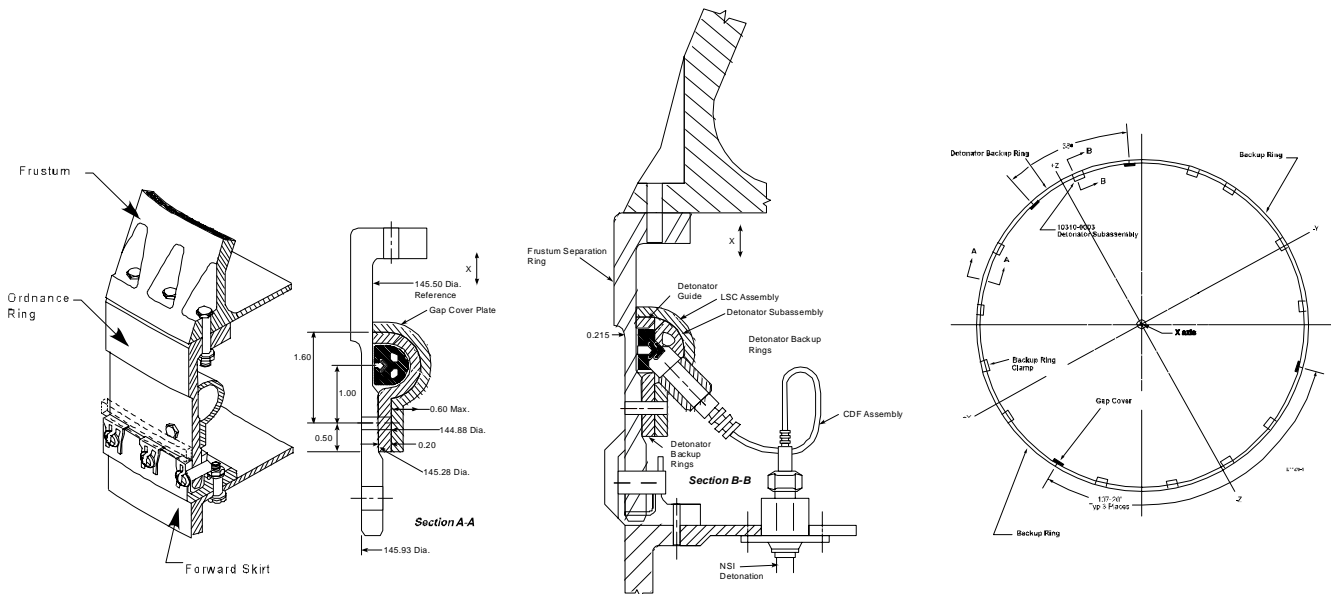

Figure 3-3. SRB Forward Separation Ring Cross Section

### 3.4 FORWARD SKIRT

The forward skirt comprises all structure between the solid rocket motor (SRM) forward segment and the forward separation ring (see Figure 3-4). It includes an SRB/ET attachment fitting which transfers the thrust loads to the ET and a forward bulkhead that seals the forward end of the skirt. Figure 3-5 shows the forward assembly (nose cap, frustum, and forward skirt). The SRB/ET attachment ball fitting provides load transfer capability in the X, Y, and Z directions. The skirt provides the necessary structure to react to parachute loads during deployment and descent. The skirt also provides a hard-point connection for the parachute risers utilized during retrieval operations. Secondary structure is provided for mounting components of the Electrical and Instrumentation (E&I) subsystem, the range

safety panels, and the systems tunnel components. The skirt assembly also includes the camera housing, , the C-Band transponder and antenna attachments, range safety subsystem (RSS) antenna locations, and RSS crossover cable feed-through housing. The skirt is approximately 125 inches long, 146 inches in diameter, and fabricated from 2219 aluminum.

### 3.5 FORWARD ATTACH FITTING

The SRB Attach Fitting is a thrust fitting located on the external wall of the forward skirt at station 442.968. The fitting is a spherical design that allows the fitting, when mated, to articulate with rotational movements of the SRB during flight. The fitting is made from 2219 aluminum forging and tempered to T352 per MIL-H-6088E. The design also allows the fitting to accept shims for vertical alignment during the mating operation. Provisions are made in the fitting to accommodate the separation bolt and capture the debris that is generated during the separation sequence. The separation bolts will be discussed as primary functional components of the separation subsystem. Figure 3-6 shows the forward attach fitting as it is positioned on the forward skirt. See Figures 3-7 through 3-10 for additional forward attach fitting detailed views.

### 3.6 AFT ET ATTACH RING

This ring is of segmented construction of 4130, 4340, and Inconel 718 steel and completely encircles the SRM. The structural integrity is sufficient to accommodate the SRB/ET aft attach strut loads. It is approximately 164 inches in diameter, 16 inches high, and its center is located at station 1511 on the SRM case. The 4 segments are bolted to the motor case at 532 locations, then joined by 16 splices and 8 angle caps including a splice buildup over the systems tunnel (Figures 3-11a and 3-11d show splice plate details). The ring is fabricated to house the aft IEA and provides attach points for the three aft struts at the upper, diagonal and lower strut (H) fittings. The ring has a forward flange and an aft flange, constructed of 4130 steel, which are attached to and supported by intercostals, strut fitting assemblies, and cable support brackets. Each forward flange and aft flange has a web and ring cap. Protective covers encircle the entire ring assembly with special covers designed for the strut and Aft IEA, which is centerlined approximately at the +Z axis. Figure 3-12 shows an illustrative picture of the attach ring on the SRM.

### 3.7 SRB/ET AFT ATTACH STRUTS

The SRB/ET aft attachments are three struts that physically attach the SRB to the ET as shown in Figure 3-10. These struts are adjustable for lateral alignment capability during assembly. They are designed to react to lateral loads induced by the SRB/ET movements on the pad resulting from ET cryogenic loading and the dynamic loads associated with liftoff and ascent. The struts are also designed to provide a plane for SRB separation. The pyrotechnic bolts housed in the struts, used to bring about the separation of the SRB/ET, will be discussed as functional components of the separation subsystem. Figures 3-13 through 3-19 show the struts. The upper strut has an external flange on each side of the separation plane to accommodate the pull-away connectors on the seven cables symmetrically arranged around the strut. There is an environmental protective cover over these cables attached to the strut. The above description of the upper strut points out the essential differences between it and the other two aft struts. The strut material of construction is Inconel 718 bar stock and forging.

### 3.8 SYSTEMS TUNNEL

The SRB systems tunnel (Figure 3-21 through 3-25), located outboard of each SRB, houses the electrical cables associated with the E&I subsystem, the DFI cables, the ground environmental instrumentation (GEI), heater cables, and the linear shaped charge of the range safety subsystem



(RSS). The tunnel provides lightning, thermal, and aerodynamic protection and mechanical support for the cables and charge. The tunnel cover attaches to a tunnel floor assembly that is vulcanized to Ethylene Propylene Diene Monomer (EPDM) rubber pads using Chemlok 205/236E. The rubber pads, in turn, are bonded with EA919 adhesive (modified with Cab-O-Sil) to the SRM case segments. The tunnel floor assemblies are provided by the structures contractor to the SRM contractor who then bonds them to the SRM case. The multi-sectional tunnel is manufactured from 2219 aluminum and extends from the forward skirt along the SRM case to the aft skirt. The systems tunnel is approximately 10 inches wide and 5 inches high. Cable mounting brackets, lightning bonds, splice plates, and other bracketry are integral to the systems tunnel. Cover sections are readily removable for access to the cable runs at any point along the systems tunnel. A protuberance at the aft end of the tunnel encloses a connector mounting plate feeding cables to the aft skirt. The aft skirt feed-through has been redesigned to accommodate the GEI and heater cables. This causes the feed-through to stand higher and wider than previously.

### 3.9 AFT SKIRT

The aft skirt provides attach points to the mobile launcher platform (MLP) and provides support to the shuttle on the launch pad for all conditions prior to booster ignition. The aft skirt provides aerodynamic protection, thermal protection, and mounting provisions for the Thrust Vector Control (TVC) subsystem and the aft mounted BSMs. The aft skirt provides sufficient clearance for the SRM nozzle at full gimballed travel. The skirt is shown in Figure 3-26. The skirt assembly is a conical shape with a 146-inch minor diameter, a 208.2-inch major diameter, and a 90.5-inch length. It has an integral stringer/skin construction welded to four forged holddown posts with bolted-in rings fabricated from 2219 aluminum. Figures 3-27 through 3-29 show the interface between the holddown post and the MLP support post. Figures 3-29a and b show a picture of the hold-down posts (HDPs) and the NASA Standard Initiator (NSI) cabling. On each SRB (left and right), the two holddown posts on the north side have blast shields installed to protect the interface between the aft skirt holddown posts and MLP support posts from the back blast of the RSRM motor exhaust. The aft skirt kick ring (a portion of which is shown in Figure 3-30) provides the necessary structural capability to absorb and transfer induced prelaunch loads. The kick ring, which bolts to the skirt, is machined from a rolled ring forging of D6AC steel. This structure is configured for both left and right SRBs. The thermal curtain (shown in Figure 3-31) is mounted between the aft skirt and the SRM nozzle for thermal protection. A lift-off umbilical with nine electrical connectors, requires an SRB/Ground Support Equipment (GSE) interface at the aft skirt. The umbilical provides cable interface for the GEI, the SRM joint heater power and heater sensor, and aft skirt strain gage cables for the SRB. Four of the nine electrical connectors are for strain gage measurements: two for joint heater power, one for GEI, and two for heater sensor/GEI. The GSE end of the connector, which mates with the lift-off umbilical, is constructed so that the connection will not be broken due to any motion during thrust buildup prior to lift-off.

### 3.10 SRB THERMAL PROTECTION SUBSYSTEM (TPS)

The TPS baseline consists of various materials selected for their unique ablative and physical properties. Two primary materials are cork and Marshall Convergent Coating (MCC-1), a MSFC developed spray-on ablative material. MCC-1 is used on the frustum, forward skirt, nose cap, aft skirt, and on a portion of the systems tunnel. Cork is used on the SRB aft skirt, SRB/ET attach ring, BSMs, strut fairings, systems tunnel, and forward crossover components (see Figure 3-32).

MCC-1 is applied by spray application in thicknesses ranging from 0.090 inches to 0.500 inches. After buildup to the required thickness, a topcoat is sprayed on to provide water resistance. MCC-1 is a low density material weighing approximately 30 pounds per cubic foot. Buildup is removable through the

use of a Gantry Robot using high-pressure water jets operating at 17,500 pounds per square inch (psi). Cork is applied to the aft skirt and other areas using an epoxy adhesive and ranges in thickness from 0.125 inches to 1.50 inches. Cork is a higher density material than MCC-1 and weighs approximately 32 pounds per cubic foot. Cork removal is accomplished by the same hydro-lasing technique as used for removal of MCC-1.

Two trowelable ablators, Booster Trowelable Ablative (BTA) and RT455, are used to closeout between insulated areas; protect fasteners, etc.; and to insulate complex structures such as the aft BSM supports. Molded glass phenolic segments are used on the aft skirt kick ring. The segments (0.25 inches thick) are retained with mechanical fasteners. Ethylene Propylene Diene Monomer (EPDM) rubber (0.5 inches thick) is used on the strut/attach ring closeout covers. The rubber bears against the struts but does not form a seal. The attach ring/strut cavities are filled with silicone foam and a 0.25-inch thick layer of trowelable silicone rubber is between the foam and closeout covers to restrict the flow of hot gases.

The thermal curtain assembly consists of three layers of quartz cloth, fiberfrax insulation, and fiberglass cloth. The outer blanket has two layers; the inner blanket is a single layer. The assembly consists of 24 segments installed circumferentially between the SRB nozzle compliance ring and aft skirt aft ring with mechanical fasteners. Adjoining blanket segments are tied together with ceramic sleeving.



Figure 3-4. SRB Forward Skirt Showing Details



Figure 3-5. SRB Forward Assembly (Nose Cap, Frustum, Forward Skirt)

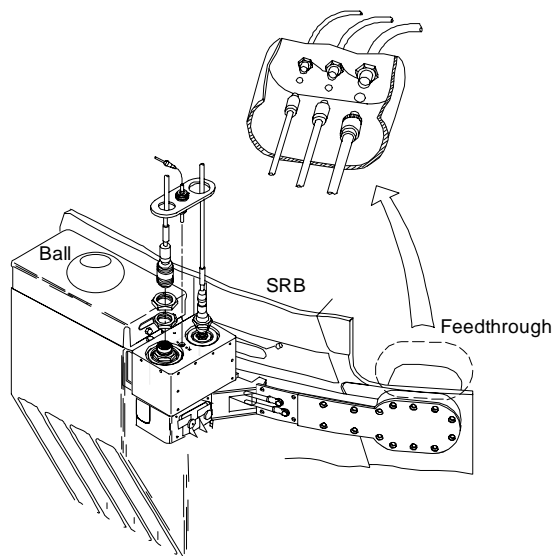

RSS Crossover and Cable Routing

Figure 3-6. Right SRB/ET Forward Attach and RSS Crossover

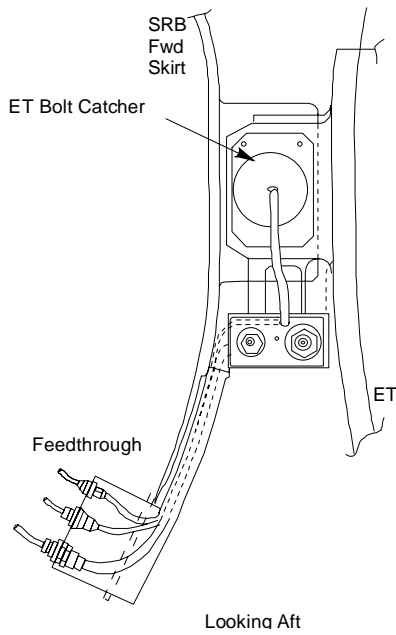

Figure 3-7. Right SRB/ET Forward Attach and SRB Cable Routing

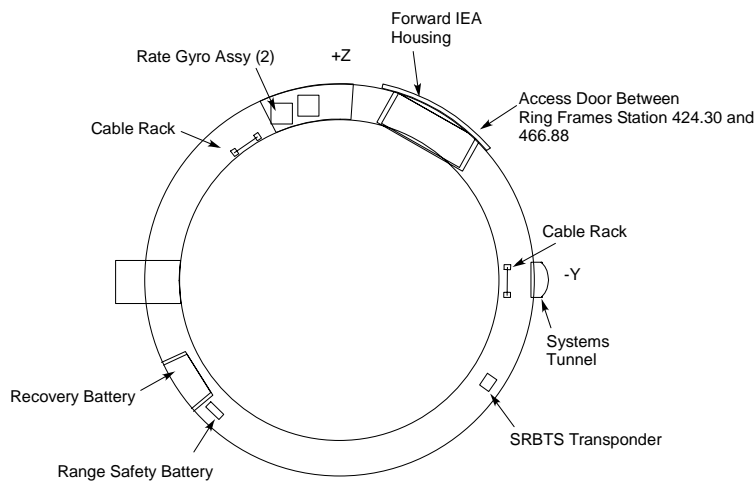

Figure 3-8. SRB E&I Hardware Locations (Fwd Skirt)

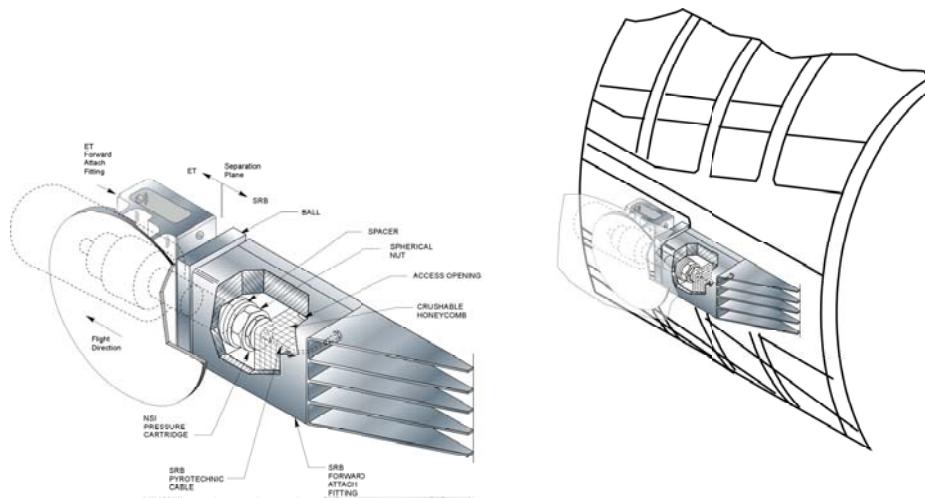

Figure 3-9. SRB/ET Forward RH Attach Fitting

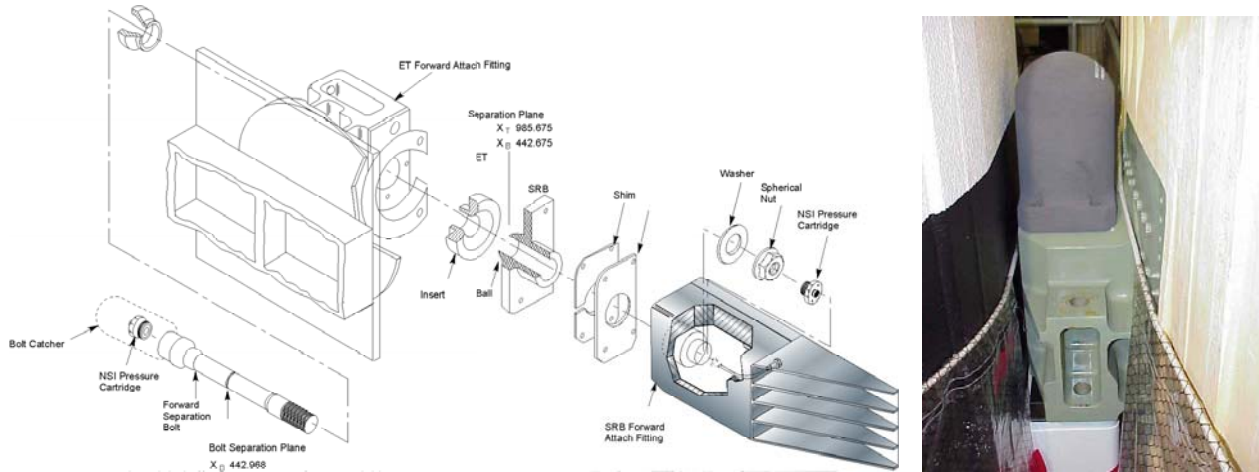

Figure 3-10a. SRB/ET Component View and Picture of Forward Attach Thrust Post



Figure 3-10b. Forward Attach Bolt Catcher (cutaway)

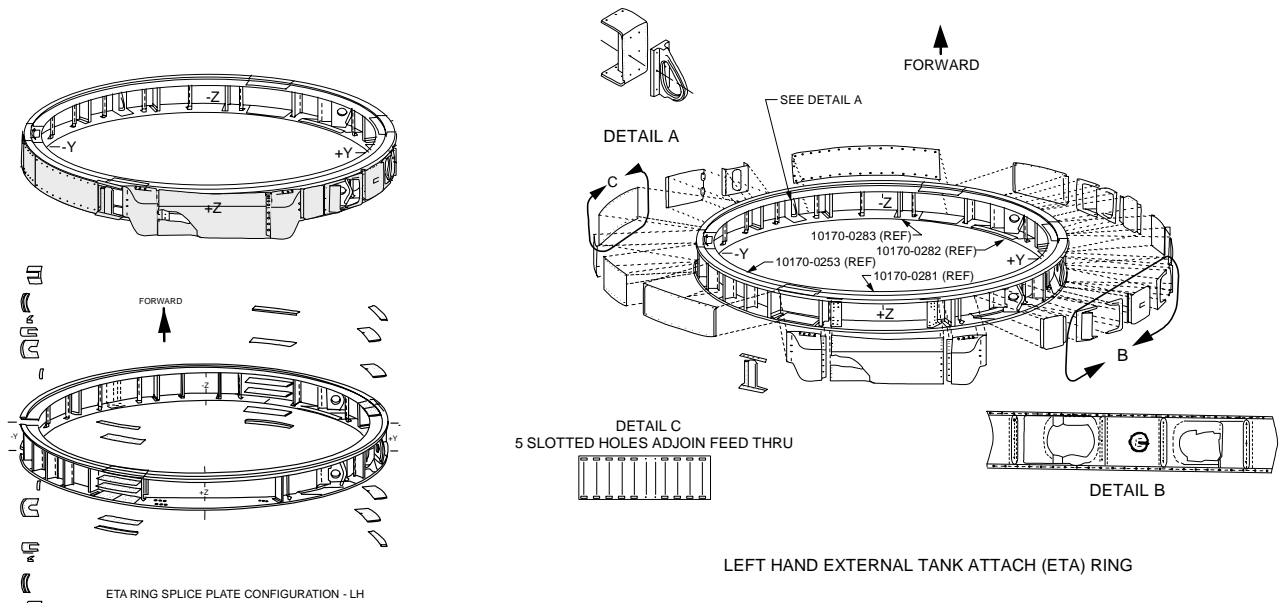

Figure 3-11a. External Tank Attach Ring Structure Overview (Insulation Omitted for Clarity)

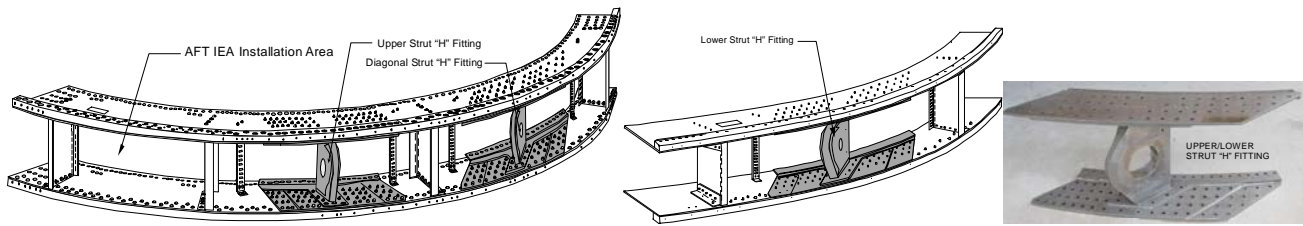

Figure 3-11b. ETA Ring Strut Connections

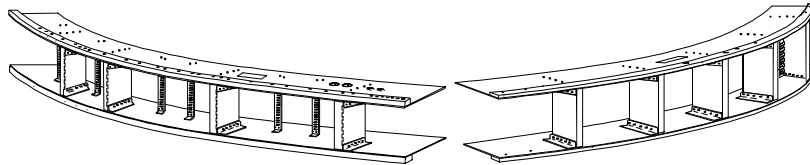

Figure 3-11c. ETA Ring Segments Structure

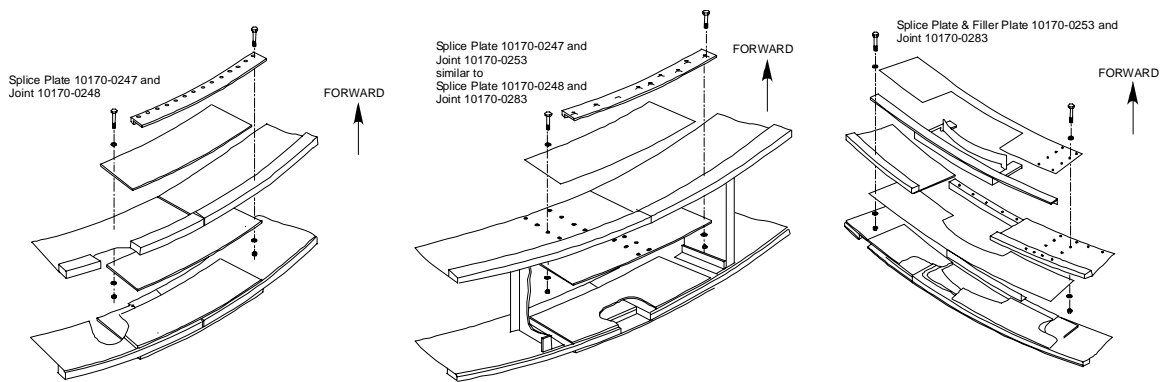

Figure 3-11d. ETA Ring Splice Plates and Joints Configuration

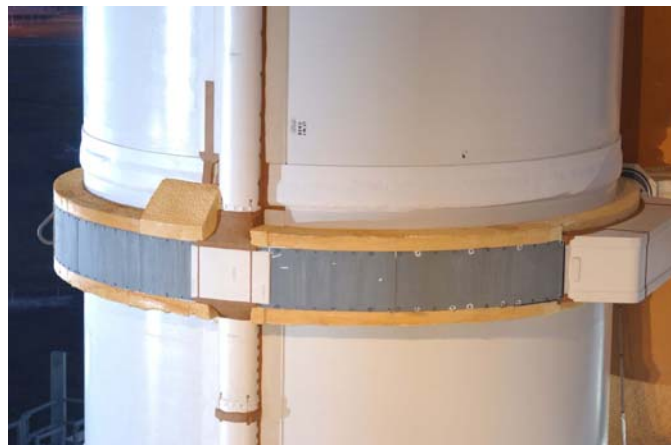

Figure 3-12. External Tank Attach Ring Showing System Tunnel and IEA Cover

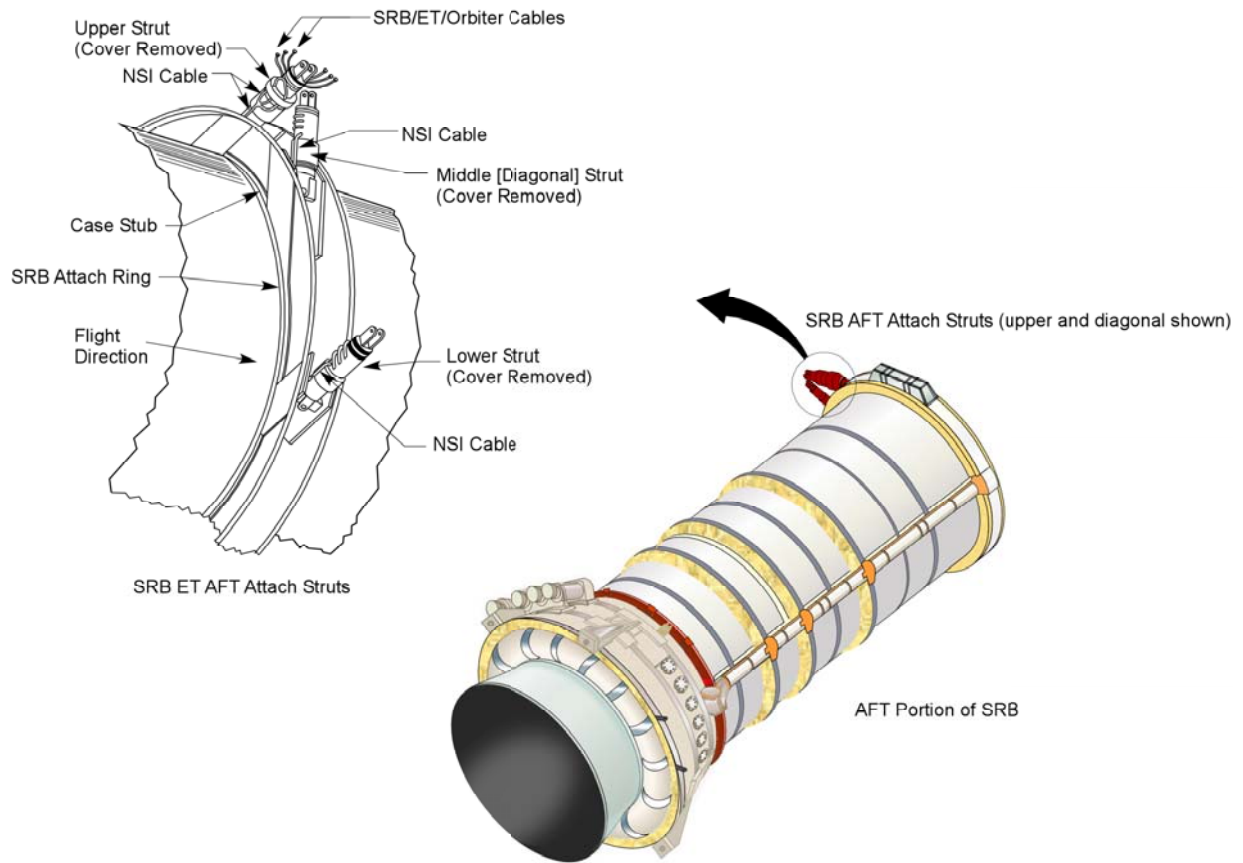

Figure 3-13. External Tank Attach Ring Showing Connection Struts



Figure 3-14. External Tank Attach Ring Showing Pre and Post Separation Strut Condition.

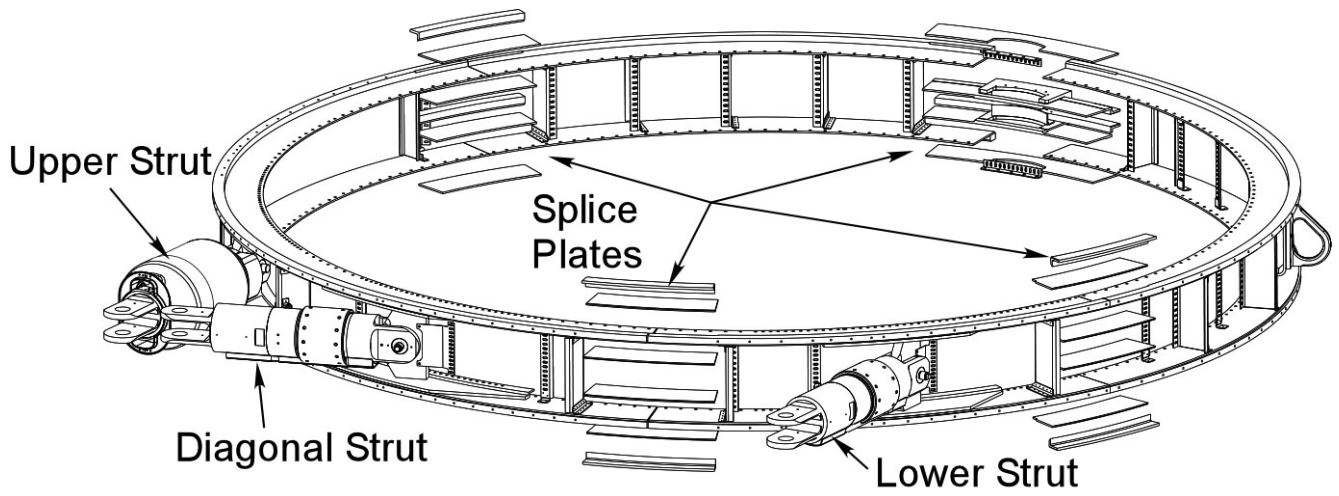

Figure 3-15a. SRB/ETA Ring Structure

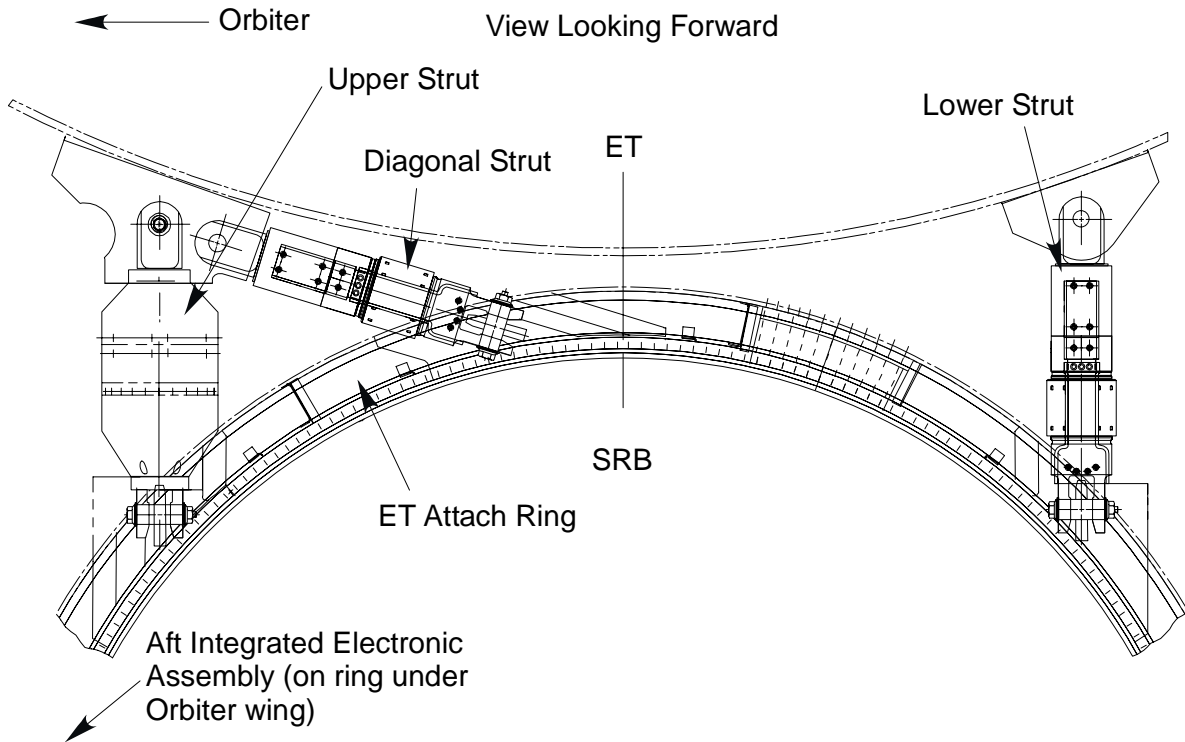

Figure 3-15b. SRB/ETA Struts Orientation to Flight Configuration



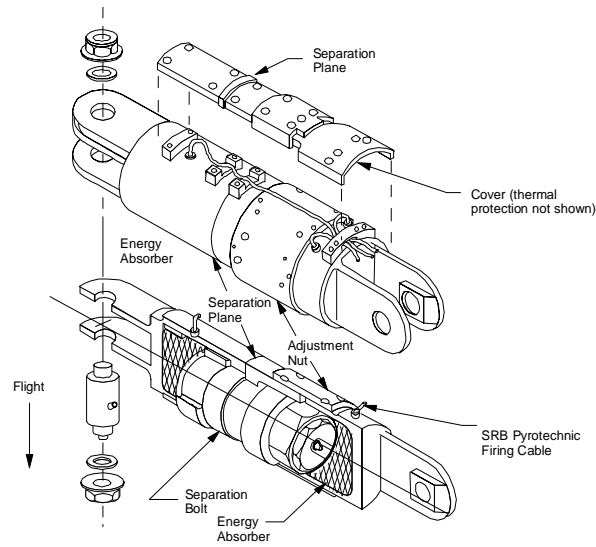
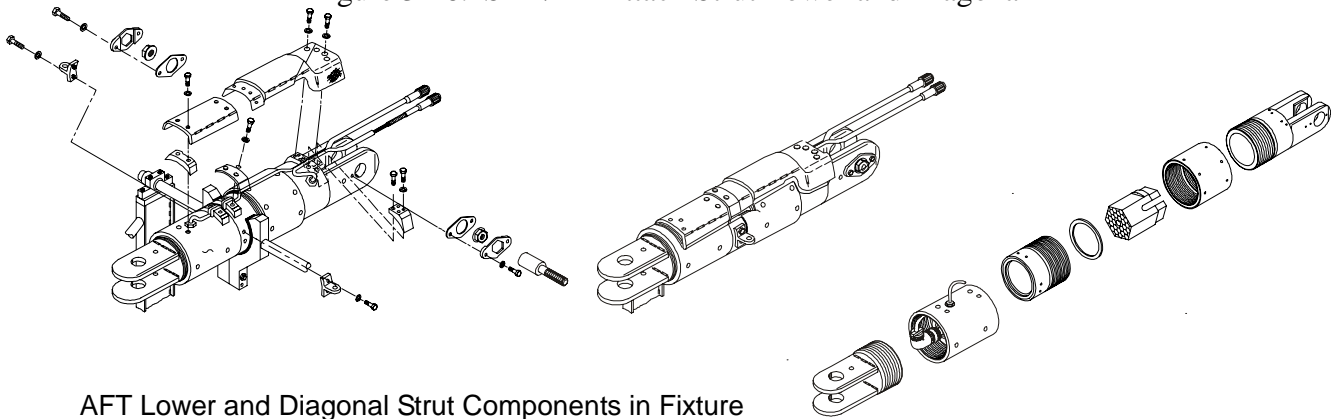

Figure 3-16. SRB/ET Attach Strut Lower and Diagonal



AFT Lower and Diagonal Strut Components in Fixture

Figure 3-17. SRB/ET Lower And Diagonal Attach Strut Expanded View

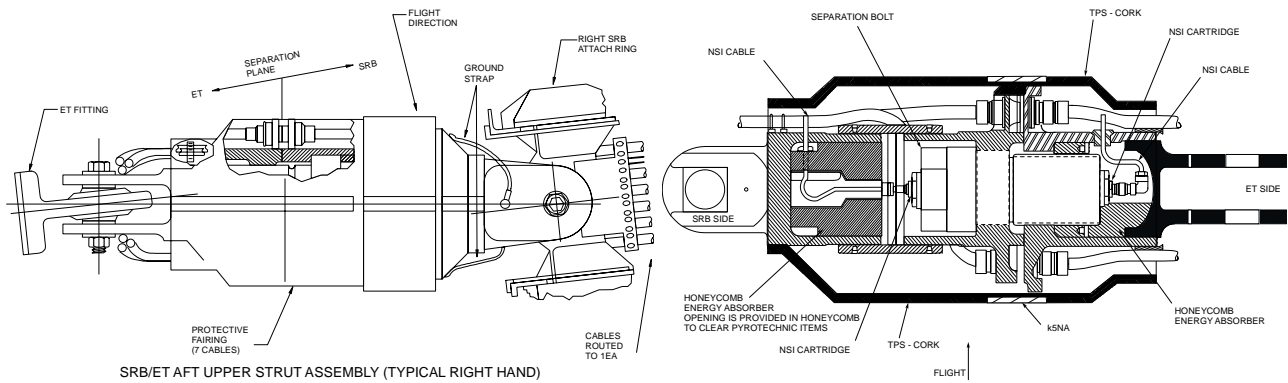

Figure 3-18. SRB/ET Upper Strut Assembly

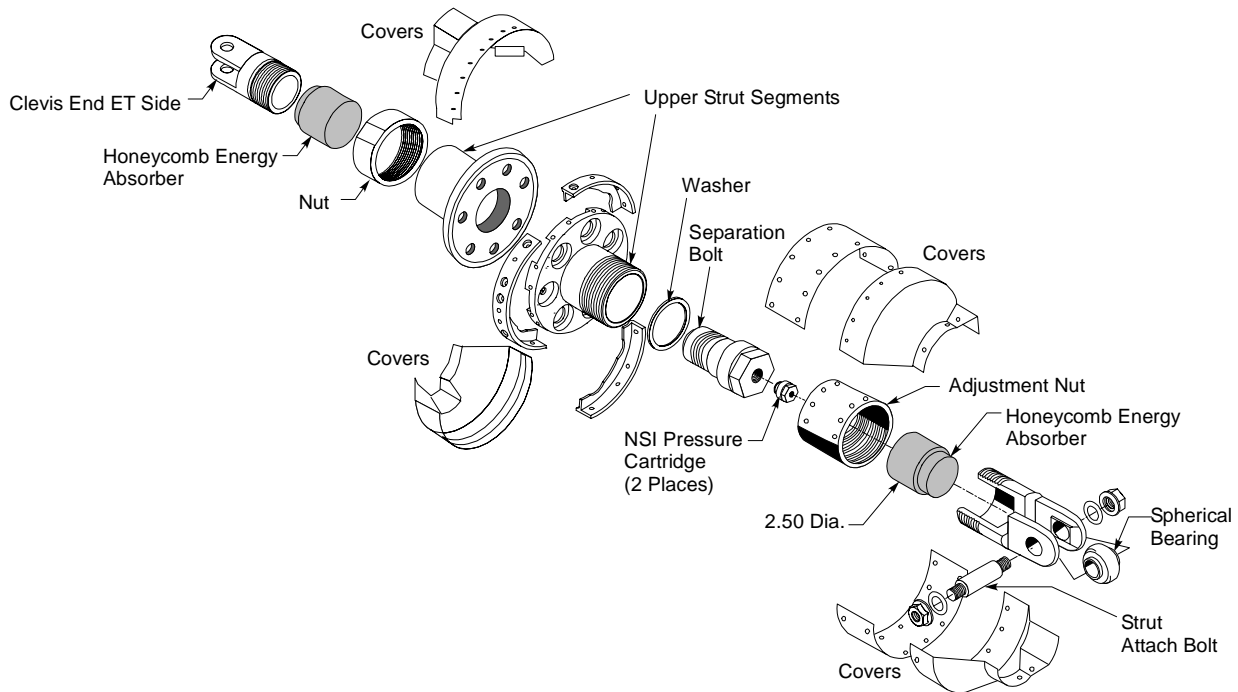

Figure 3-19. SRB/ET Upper Attach Strut Expanded View

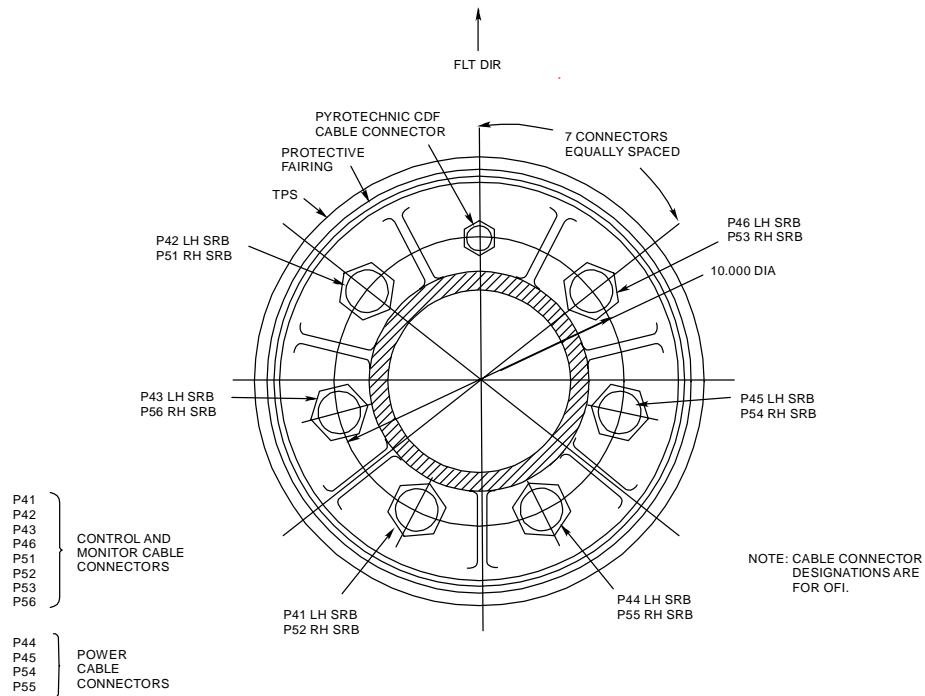

Figure 3-20. Upper Strut Cable Pass-through Connections

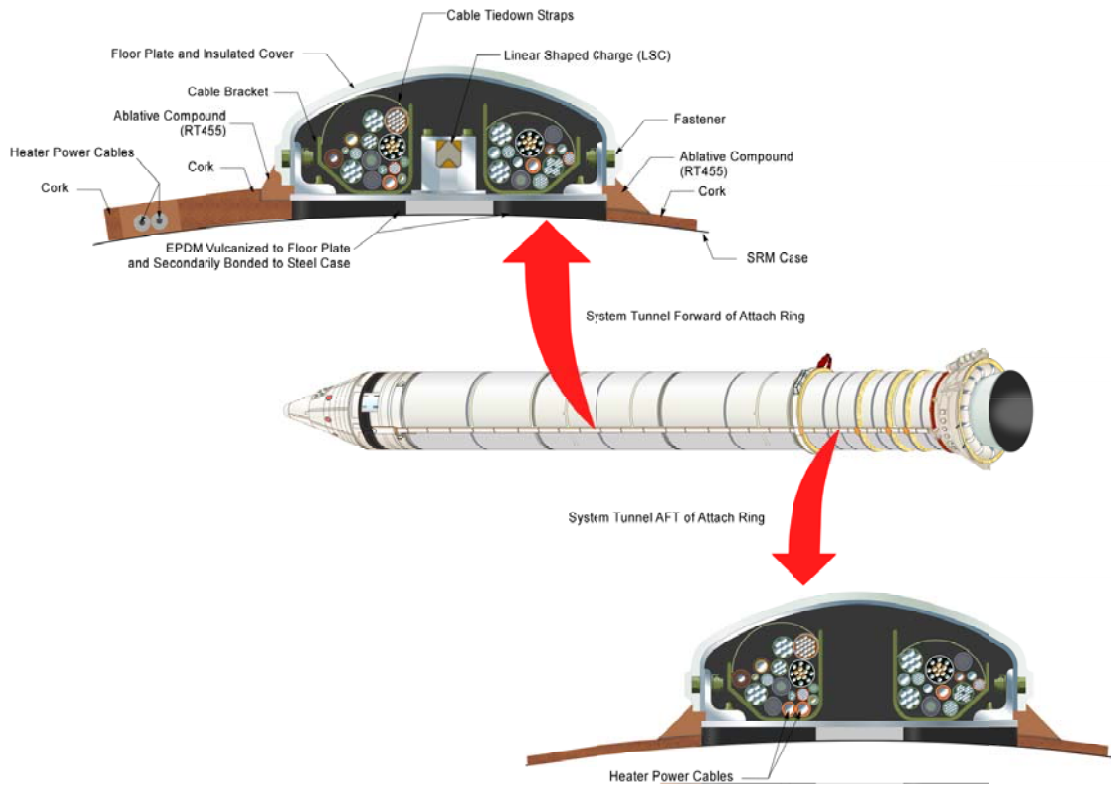

Figure 3-21. Systems Tunnel Configuration

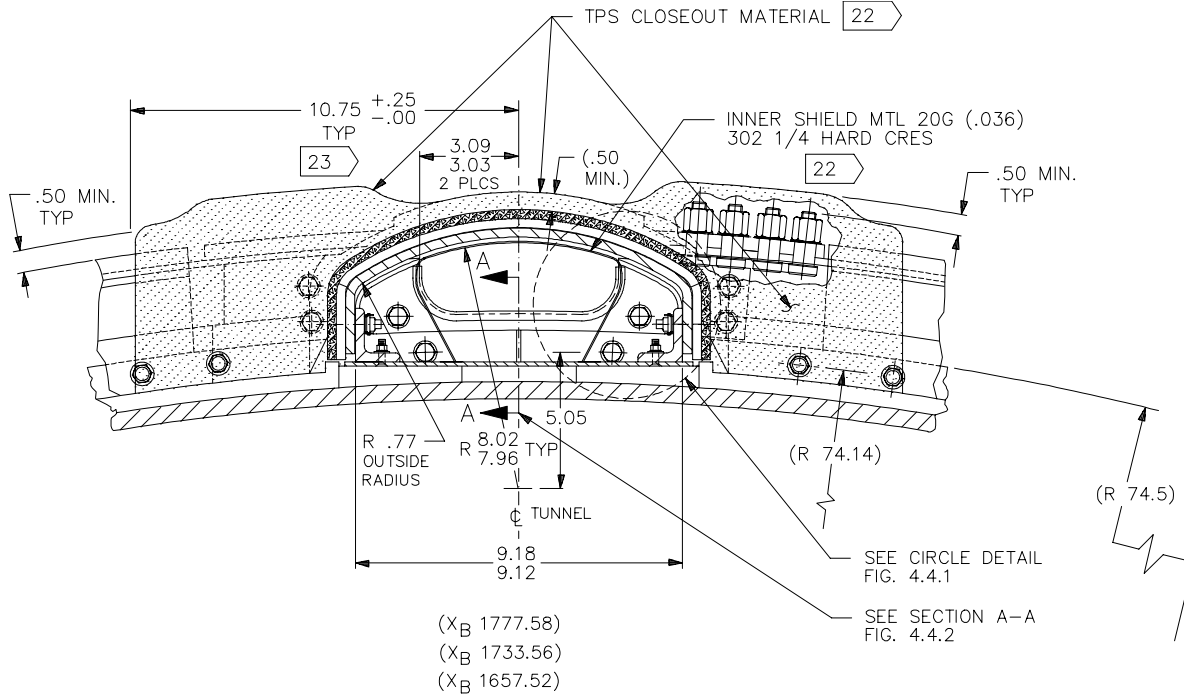

Figure 3-22. Systems Tunnel Configuration Section Details

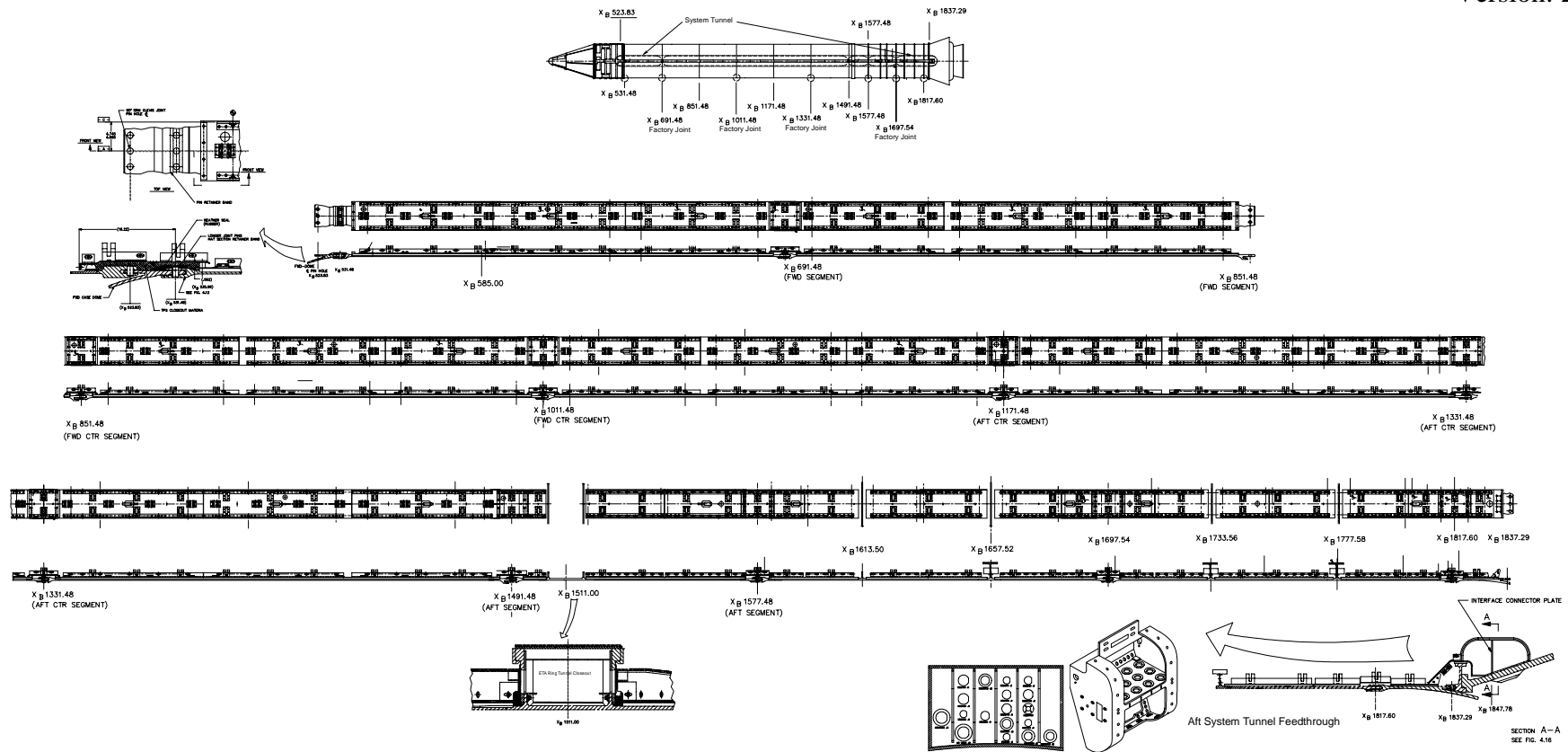

Figure 3-23. SRB Systems Tunnel Floor Geometry and Layout

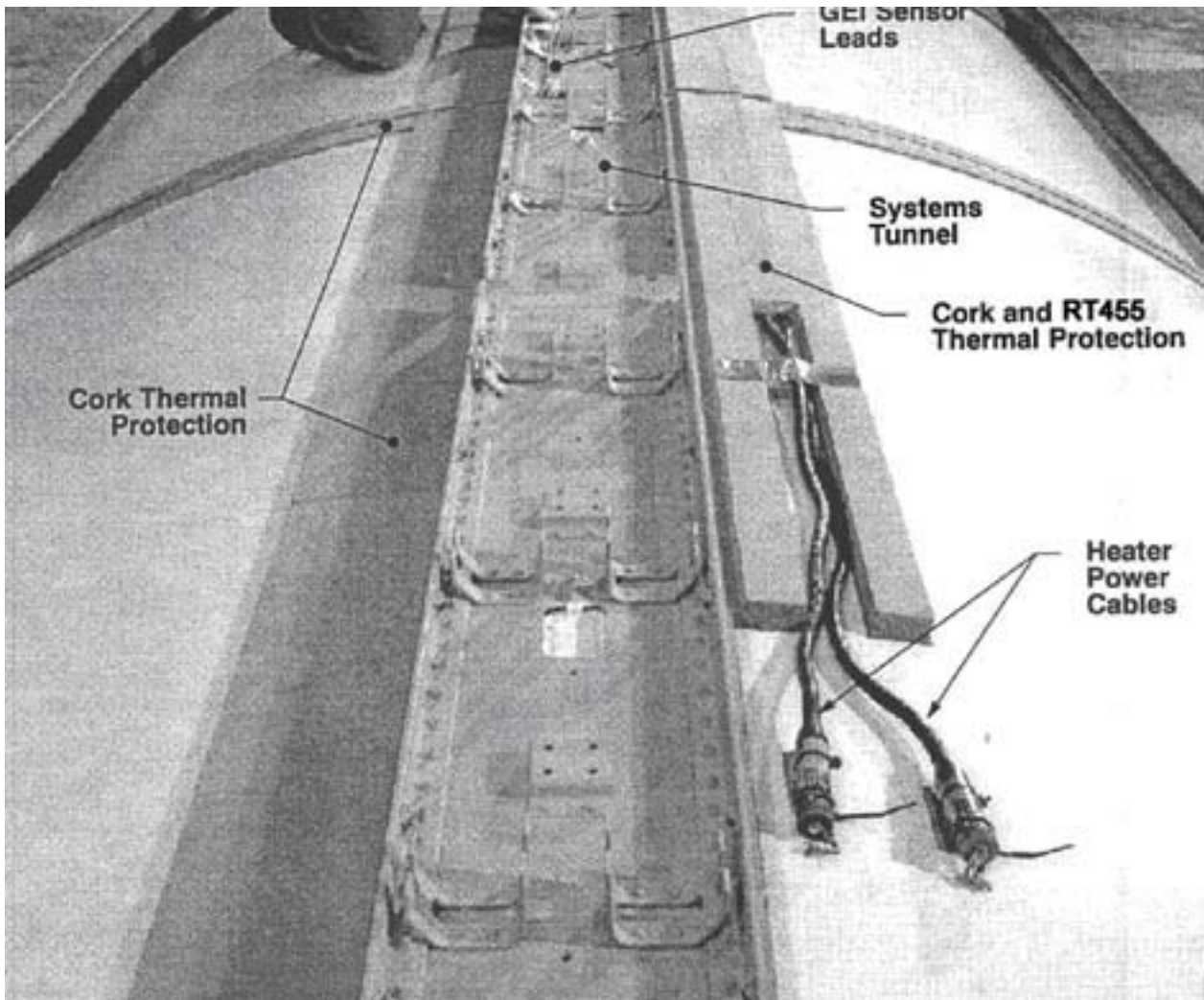

Figure 3-24. Systems Tunnel on RSRM



Figure 3-25. Systems Tunnel Configuration Fwd & Aft Connections (Canoe and Rooster Tail)

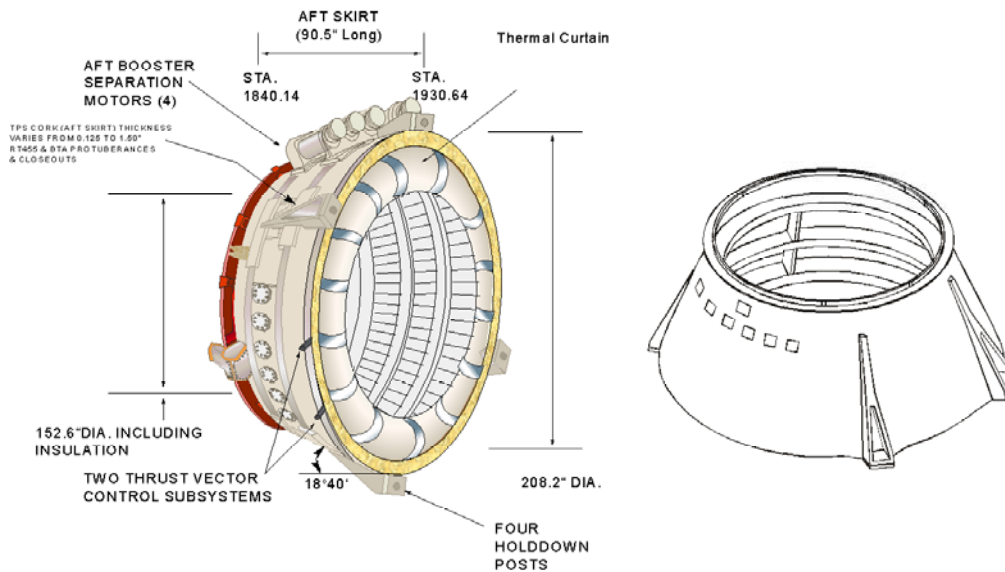

Figure 3-26. SRB Aft Skirt Detail (SRM Nozzle not shown for Clarity)

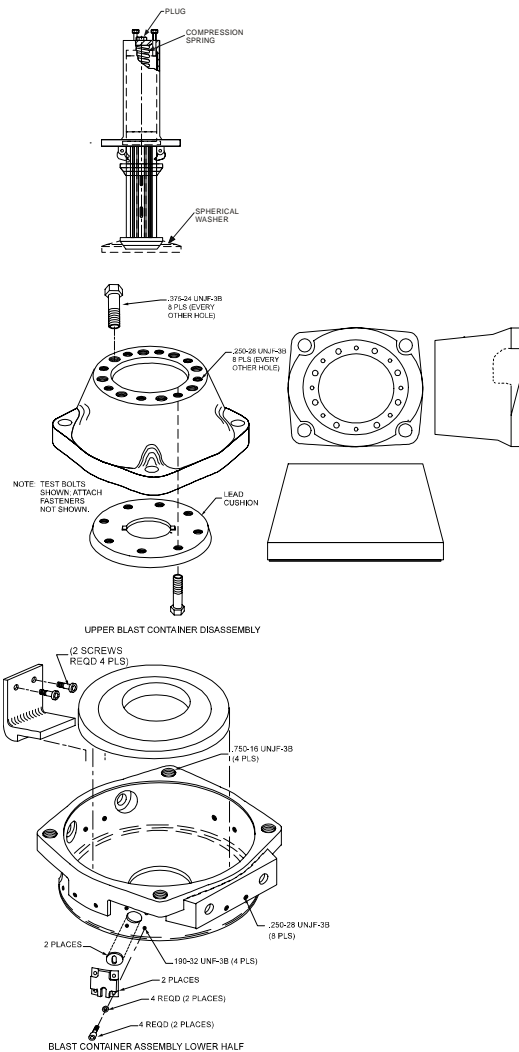

Figure 3-27. SRB Holddown Connection Components at MLP

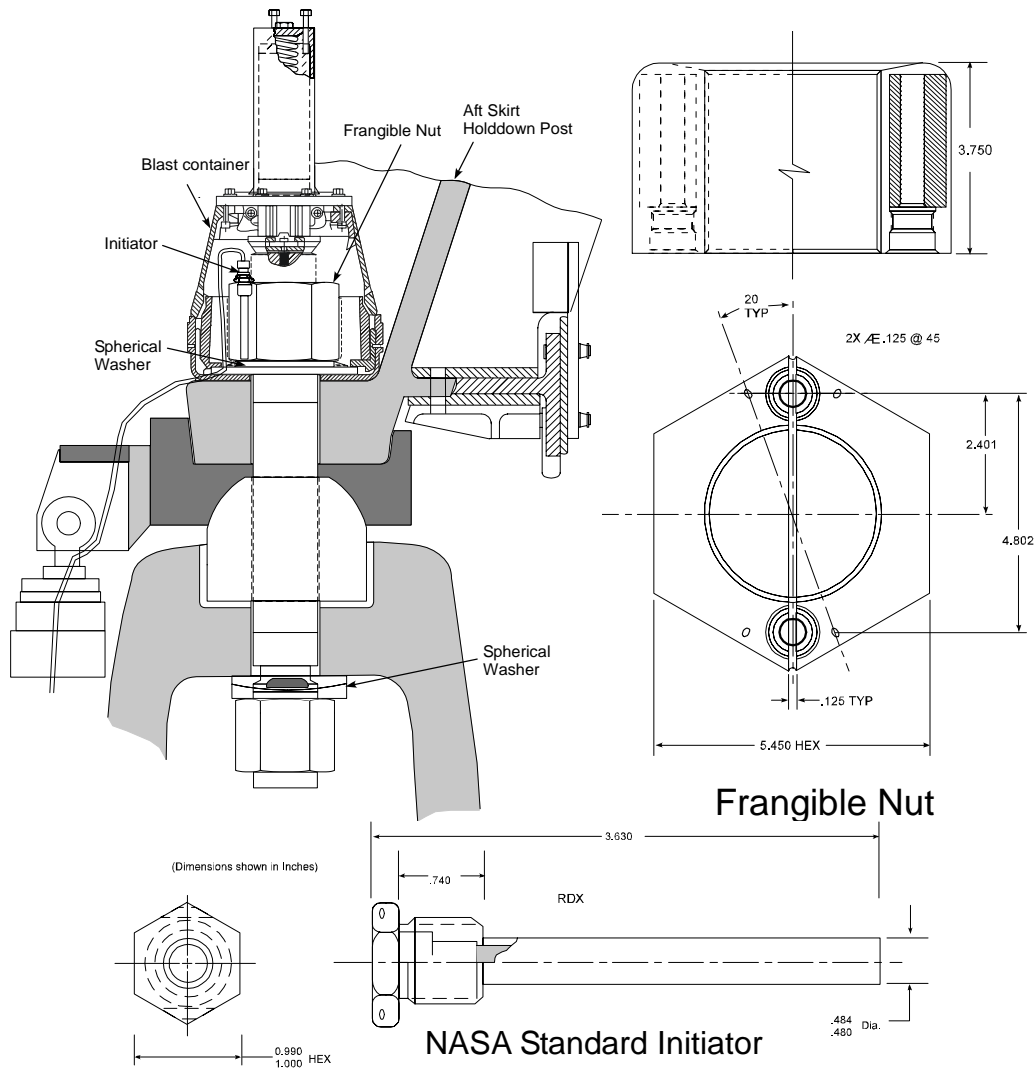

Figure 3-28. SRB Holddown Section and Components



Figure 3-29a. SRB Holddown Views

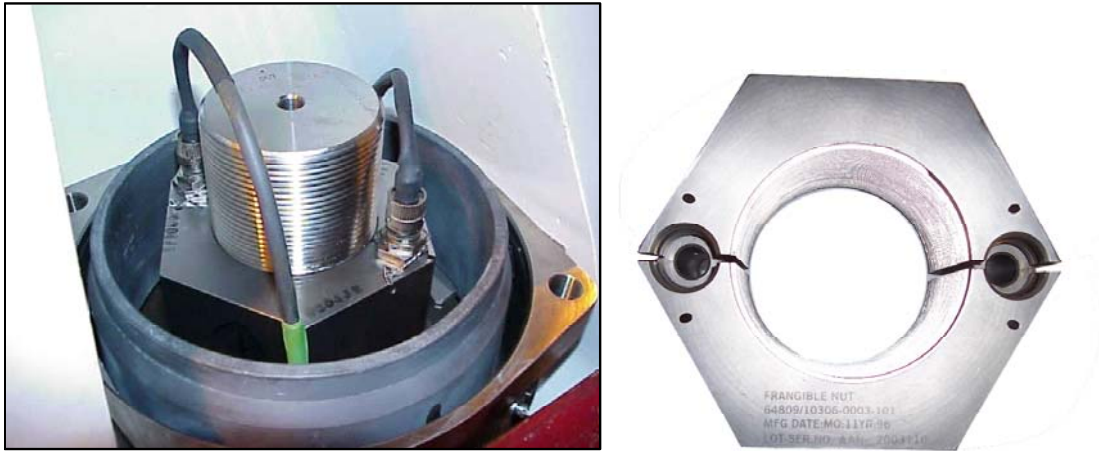

Figure 3-29b. SRB Holddown Stud showing Frangible Nut and NSI Cabling

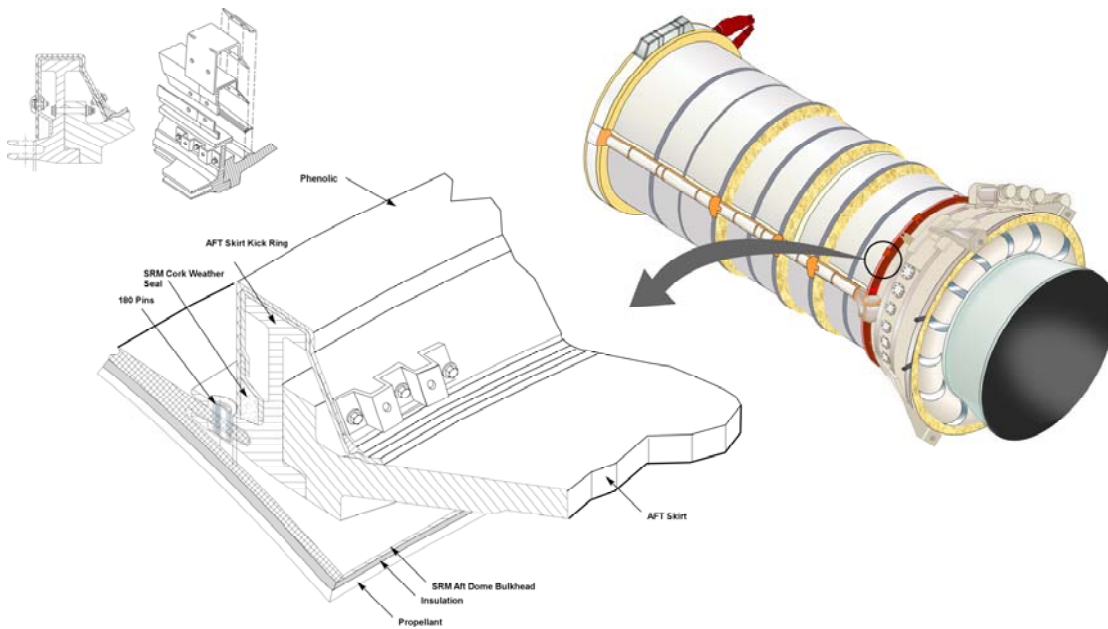

Figure 3-30. SRB Aft Skirt/SRM Case Attach Detail



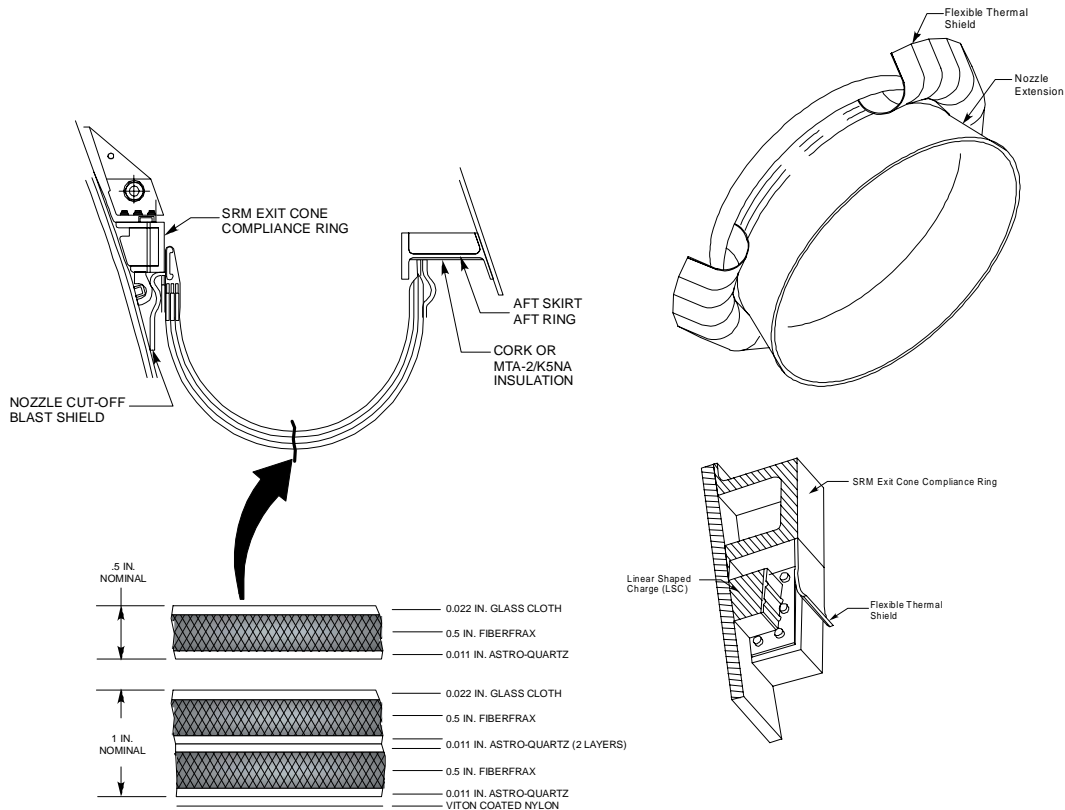

Figure 3-31. SRB Aft Skirt Thermal Curtain Configuration

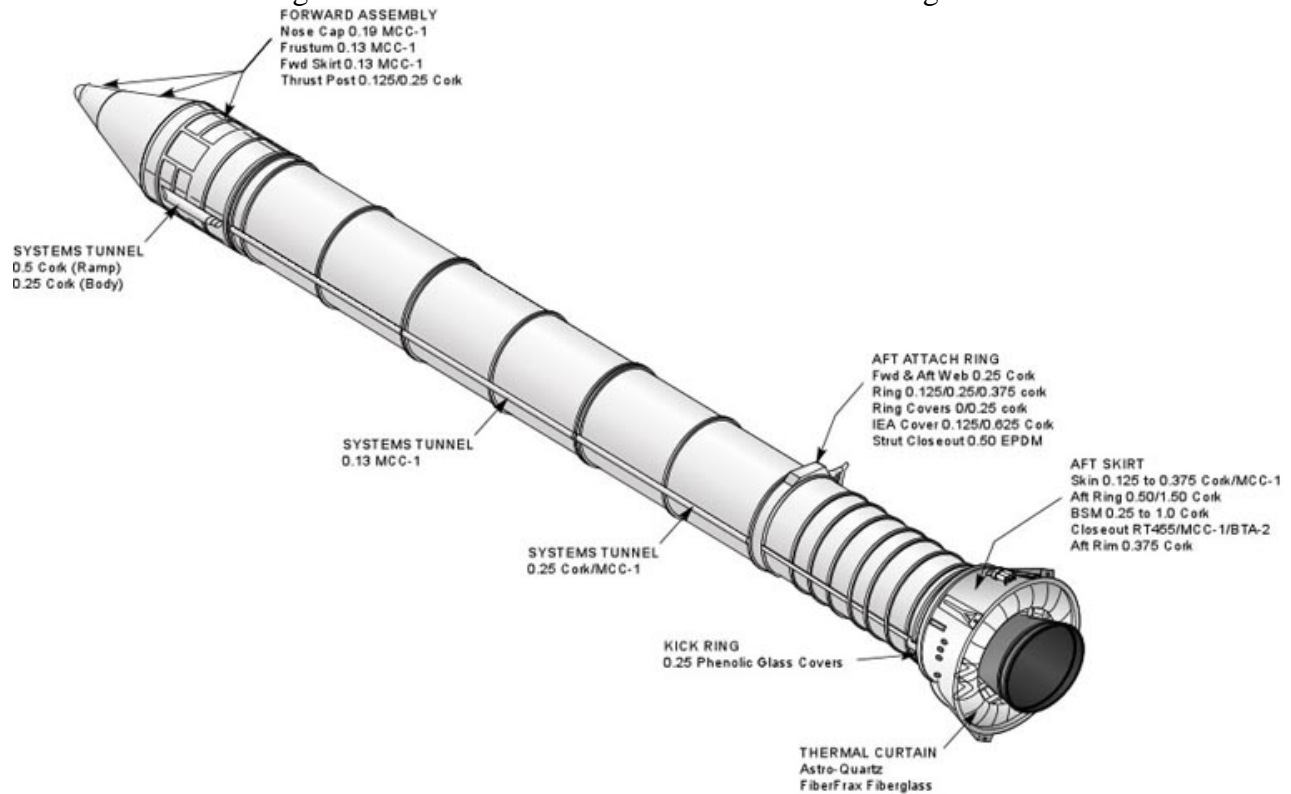

Figure 3-32. SRB Thermal Protection Subsystem General Configuration

## 4.0 ELECTRICAL AND INSTRUMENTATION SUBSYSTEM

### 4.1 GENERAL.

The Electrical and Instrumentation (E&I) subsystem components with the interconnecting cabling provide the means to test, calibrate, and monitor the SRB prelaunch conditions and connect the SRBs with the orbiter vehicle during launch and boost phases for range safety, power distribution, control, pyrotechnic initiator controllers, signal conditioning equipment, switching and logic circuits, sensors, sequencing circuits, ET/SRB separation, and SRB recovery functions after separation.

Central to operation of the SRBs are the integrated electronic assemblies (IEAs). Each SRB has two IEAs. The forward IEA is located in the forward skirt and the aft IEA on the ET attach ring. Figure 4-1 and 4-2 illustrates the location of each IEA relative to its structural member. Figure 4-3 shows the typical components of an IEA and Figures 4-4 and 4-5 show specific forward and aft IEA component designations. Figures 4-6 through 4-8 delineate specific attributes of the forward and aft IEA components showing connectors and functionality. Tables 4-1 and 4-2 define the components included within each IEA. Table 4-3 defines the physical attributes of the IEA unit. Located in each IEA is a multiplexer/demultiplexer (MDM). The MDMs are the nerve center for the SRB and communicate with GSE or orbiter computers via launch data buses (LDBs). The LDBs are redundant, but an MDM will respond to only one bus at any given time.

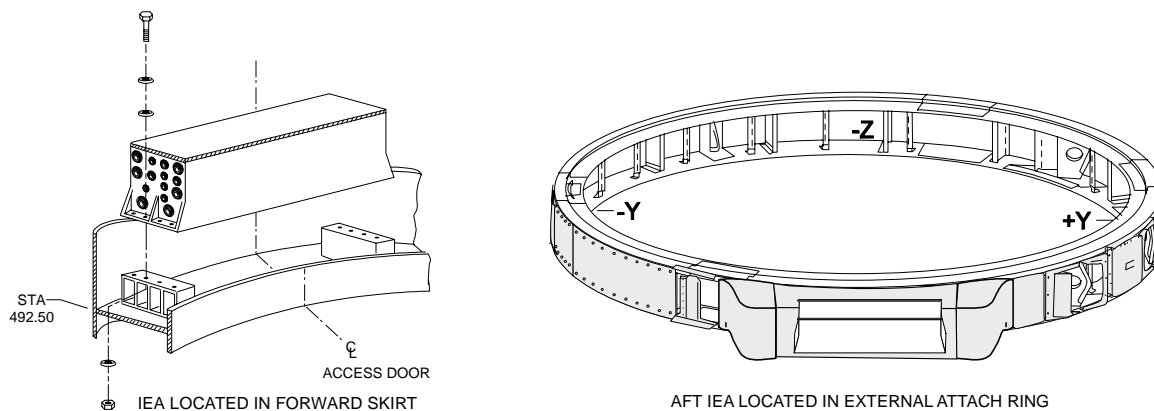

Figure 4-1. Forward and Aft IEA Locations within SRB Hardware.

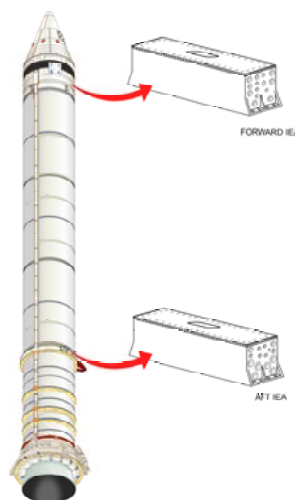

Figure 4-2. Forward and Aft IEA Locations Relative to SRB Assembly.

During prelaunch and test activities, the MDM functions to control and monitor the SRB subsystems by discrete outputs, discrete inputs, and analog input measurements. Just prior to launch, four discrete output channels (64 discrettes) of each MDM are "locked out"; these 64 discrettes (16 discrettes per channel, 2 lockables per DOL module, 2 DOL modules:  $2 \times 2 \times 16 = 64$ ) are electronically inhibited from changing. Any discrettes in this group that are "on" prior to lockout will remain "on" and those that are "off" will remain "off". The remaining 32 discrete outputs can be controlled after launch, but no flight critical functions are assigned to this group. MDM input channels are not affected by lockout. Input measurements can be monitored during the entire ascent. No flight critical data is input via the SRB MDM. At separation the power buses are disconnected, removing power to the MDMs.

Power for the SRB E&I subsystem on operational flights is from six separate power sources. The aft IEA is cabled to the orbiter A, B & C buses. The forward IEA is cabled to the aft IEA and receives power from these sources in the stacked configuration. Range safety and recovery subsystems are powered by 28-volt batteries located in each SRB. The sixth power source is a 26 VAC, 1000Hz system (Excitation Bus) supplied from the orbiter for the TVC differential pressure transducers. The power for the Developmental Flight Instrumentation (DFI) subsystem is a separate battery.

#### 4.2 E&I SUBSYSTEM DESCRIPTION.

The SRB E&I subsystem functional diagram is depicted in Figure 4-9. Prelaunch functions include test and calibration of SRB components, including SRM ignition components. The E&I subsystem cabling and components provide the interface with the Orbiter Vehicle (OV) for the SRB TVC subsystem, SRB rate gyro assemblies, SRB/ET separation subsystem, and SRB Range Safety System (RSS) during the boost phase of flight and the recovery functions after separation. The E&I subsystem also contains sensors, signal conditioning equipment, pyrotechnic initiator controllers (PICs) shown schematically in Figure 4-10, switching and logic circuits, various buffers, interfaces, timers, sequencing circuits, and auxiliary power unit (APU) controllers used to regulate the speed of the TVC APUs. The functional schematic of the TVC APU Controller is shown in figure 4-11. These circuits provide a means for responding to commands from the OV during boost and provide circuitry to sequence separation of the SRBs and deploy parachutes. E&I subsystem components associated with the SRB boost phase are active and powered by the orbiter until separation. Components associated with the recovery sequence are turned on at SRB separation and are powered by the recovery battery A. The E&I subsystem components, with the following exceptions, are designed for reuse with inspections and refurbishments, as required, for a minimum of 20 flights:

- a. Batteries
- b. Cables which have connectors exposed during recovery
- c. ETA Ring Pyrotechnic cables
- d. Cables connected to initiators that are exposed
- e. Forward and Aft Tunnel cables
- f. Rate gyro assemblies

## 4.3 E&I SUBSYSTEM FUNCTIONS

### 4.3.1 Prelaunch Functions.

The E&I subsystem data processing elements and E&I cabling are used to provide test, calibration, and monitoring functions. The prime prelaunch functions are as follows:

- a. Power-up, test, and monitor the rate gyro assemblies (RGAs)
- b. Power-up, test, and monitor the TVC subsystem
- c. Power-up, activate, test, and monitor the RSS
- d. Test and monitor the SRM ignition and separation PICs
- e. Test and monitor elements of the recovery subsystem
- f. Calibrate SRM and TVC pressure sensors
- g. SRM safe and arm (S&A) device commands and position signals
- h. Power up and test the command and data handling subsystem which includes the MDM, data bus couplers, data bus, wiring, etc.

### 4.3.2 Ascent Phase Functions.

The E&I subsystem provides the interconnecting cabling for signal conditioning, power distribution, data processing, and Operational Flight (OF) sensors to support the SRB during boost. Electrical power is supplied by the orbiter during ascent.

#### 4.3.2.1 E&I Components Active During the Boost Flight Phase

- a. Aft IEA
- b. Forward IEA
- c. RGAs
- d. Instrumentation sensors

#### 4.3.2.2 Functions Controlled or Monitored by the Orbiter through the E& I Subsystem

- a. TVC subsystem actuator and bypass commands; actuator position signals to orbiter
- b. RSS power-off, S&A safe, and inhibit commands
- c. SRM chamber pressure (used for separation cue)
- d. SRM ignition commands
- e. PIC voltage monitoring
- f. SRB/ET separation commands
- g. SRB rate gyro signals from the SRB to the orbiter (which are used in the flight control system)

### 4.3.3 SRB Recovery Functions.

The E&I subsystem functions dedicated to SRB recovery include initiation of the SRM nozzle extension severance, release of the nose cap (which deploys the pilot and drogue parachutes) and release of the frustum (which deploys the main parachutes). The SRB recovery functions are powered up just before SRB/ET separation.

#### 4.3.3.1 E&I Subsystem Components Active During the Recovery Phase

- a. Recovery battery (supplies power to the SRB recovery subsystem and provides power for the RSS) (Figure 4-18)
- b. Altitude switch assembly
- c. IEA recovery components (fwd IEA houses the recovery logic cards and the aft IEA houses the NEJ PIC card)
- d. Interconnecting cable sets

#### 4.3.3.2 Sequence of Events Controlled by the E&I Subsystem During SRB Recovery.

- a. At approximately 16,000 feet, the altitude switch assembly (ASA) releases the nose cap and the pilot and drogue parachutes are deployed.
- b. At approximately 6,000 feet, the ASA releases the frustum and the main parachutes are deployed.
- c. The SRB nozzle extension is jettisoned just before splashdown.
- d. At SRB splashdown, the main parachute risers are released from the SRB via the salt-water activated release (SWAR) assembly that activates as a function of conductivity change. The main parachutes sink to the limit of a 50-foot Kevlar extension line(s) that prevents the chutes from tangling the aft skirt. Divers then install floats and cut the extension lines.

#### 4.3.4 Data Acquisition System (DAS)

The DAS is a self-contained unit located in the forward skirt dome intended to collect video of main parachute deployment and water impact acceleration data. The container is approximately 14" x 9" x 6" and consists of 4 accelerometers, a video camera, a g-switch, a data recorder, a digital video recorder, batteries, and all associated circuitry and wiring. The system also provides an input that can be used to collect external video data that has been used in the past to record video from the ET Observation Camera. Figure 4-17 provides a picture of the DAS box.

Just after liftoff, the g-switch activated DAS begins recording acceleration and video data. Acceleration data is recorded for a software configurable duration (currently 9 minutes) while video is recorded for 60 minutes. Upon SRB recovery, the DAS unit is disassembled and data is recovered and disseminated to the SRB community for review.

#### 4.4 AFT IEA PHYSICAL DESCRIPTION,

The aft IEA is a hermetically sealed box-type component as shown in Figure 4-2. Maximum dimensions are 45 inches in length, 12 inches in height, and 11.906 inches in width. The inclusion of four steel lifting lugs at each of the four upper corners, brings the clearance required to install the aft IEA to 12.656 inches.

The basic chassis is a machined A356 aluminum casting. The top and bottom covers are fabricated from 6061 aluminum sheet and attach to the casting by screws. The covers are sealed at installation with Ethylene Propylene seals designated as Parker's compound E529-65, which provides a hermetic seal that permits the IEA to be purged via a pressure valve and pressurized with dry nitrogen to 20 pounds per square inch, absolute (PSIA). The complete aft IEA, with its internal components, weighs approximately 182 pounds.

The IEA is designed to house plug-in, solid-state printed circuit type low-voltage assemblies that serve as interfaces with IEA internal electrical harnesses. These harnesses provide internal circuit paths to input and output connectors at each end of the IEA casting. The aft IEA contains 41 plug-in assemblies. It has 14 connectors and a purge/pressure fill valve on the strut end of the IEA, and 20 connectors and a purge/pressure fill valve on the tunnel end.

The aft IEA is mounted to the SRM case between the flanges of the SRB/ET attach ring. It is installed using lifting lugs at each corner and is secured by bolting to IEA mounting plates integral to the SRB/ET attach ring flanges. Electrical connections are made by mating cable connectors to each end of the IEA. The aft IEA is a recoverable component subject to refurbishment, testing and projected use of 20 flights.

The aft IEA provides the electrical interface between the SRB systems and the OV. This interface is by cables routed across the upper aft attach strut of each SRB/ET attach point. The aft IEA receives data, commands, and electrical power from the OV, and distributes these inputs throughout each SRB. Components located in the forward portion of each SRB are powered by the aft IEA through the forward IEA, except for those using the recovery and range safety batteries that are in the forward skirt. All data from the SRBs to the OV are routed through the aft IEA across the upper aft strut interface.

The purge valves on the IEA are a standard commercial item. The lifting lugs are fabricated of ASTM A582 CL303 or 303SE steel. The completed IEA is primed with green prime epoxy, designated and its finish is a gloss black epoxy.

#### 4.5 AFT IEA FUNCTIONAL DESCRIPTION.

The aft IEA contains 41 plug-in assemblies that provide three functional capabilities in the overall operation within the E&I subsystem. These functional capabilities are distribution, multiplexing functions, and signal conditioning. Each of these functional elements is comprised of specific plug-in assemblies designed and integrated to provide the required functions within the E&I subsystem. The various plug-in assemblies for each capability will be described within each functional description.

##### 4.5.1 Distributor Function.

The distribution function of the aft IEA provides electrical power distribution, commands, control data distribution, and switching functions to various SRB components. The distributor portion of the aft IEA is designed to provide two independent channels for these functions, thereby establishing redundancy. This redundancy of channels is incorporated in the physical design of the IEA through the use of integral partitions to isolate the redundant circuitry of the distributor.

The distributor function of the aft IEA is accomplished through the use of 21 plug-in assemblies and two cable harnesses. There are nine PICs, six switching cards, two miscellaneous component boards, two APU controllers with built-in test equipment (BITE) cards. The distributor also contains two electromagnetic interference (EMI) filters and two data bus couplers.

##### 4.5.1.1 PICs.

PICs are contained in both the aft and forward IEAs. They are printed circuit board assemblies with a capacitive discharge circuit used to fire NASA standard initiators (NSIs) on command to detonate appropriate SRB ordnance devices. Two commands; issued in sequence within 40 milliseconds of each other are used to produce a capacitive discharge voltage of 40 VDC at 15 to 40 amperes. This

capacitive discharge is produced within 0.4 to 3.5 milliseconds after the commands are received, and is sufficient to activate the applicable NSI. The PICs contain built-in test circuits that permit checking, in a GO, NO GO mode, each of the PICs during the SRB countdown sequence. The nine PICs in the aft IEA are used as follows: one for nozzle extension jettison, six for aft attach separation, and two for BSM ignition.

#### 4.5.1.2 Switching Cards.

Six switching cards are used to sequence various SRB functions. These switching cards use solid-state switching circuits and interface with the internal IEA harness assemblies for routing of the switching functions to provide the required sequence of operation.

#### 4.5.1.3 EMI Filters.

Two EMI filters are used in the distributor portion of the aft IEA. These filters serve to minimize EMI generated within the other portions of the IEA and reduce the transmission of this EMI through the distributor function of the IEA.

#### 4.5.1.4 Miscellaneous Component Boards.

Two miscellaneous component boards are used to house components required to interact with other assemblies. Interfaces between printed circuit board type assemblies and other assemblies within the IEA are accomplished through the IEA harness assemblies.

#### 4.5.1.5 APU Controller Assemblies.

Two APU controller assemblies are contained in each aft IEA. These assemblies regulate the respective APU turbine speeds in response to a signal generated by the magnetic pickup unit (MPU) during normal TVC operation. The nominal APU operating speed is 72,000 revolutions per minute (RPM), and this speed is regulated to plus or minus 8 percent. Speed control is accomplished by monitoring the turbine speed through magnetic pickups located near the APU drive shaft. The outputs of these pickups- are pulse trains which are received by the APU controller assembly and wave shaped, applied to a one-shot multivibrator, filtered to a DC level, and then compared to a preset 100 percent speed voltage level in a comparator. The output of this comparator is then used to control the normally open primary fuel control valve metering the fuel to the gas generator driving the APU turbine.

The APU controller assemblies also have the capability of programming contingency modes of APU operation based upon loss or decline of pressure or decline in APU speed within the TVC. The first of these modes increases the APU speed control to 110 percent based upon loss or decline of hydraulic pressure of the opposite APU within the system. This control to 110 percent speed provides sufficient hydraulic capability to supply both TVC actuators. This 110 percent control merely increases the fuel flow to the gas generator through the normally open primary fuel control valve.

If the primary speed control fails to regulate the speed at 110%, a secondary contingency mode will limit the APU speed to 112% of nominal and control the unit at that speed.

The APU controller assemblies are powered by the OV power buses A and B via the aft IEA. Each power circuit regulates the input voltage to generate +15 VDC reference voltage and +5 VDC logic voltage. Each input voltage line is current-limited to prevent a short from loading the input power bus. Figure 4-12 illustrates the TVC APU controller function.

#### 4.5.1.6 Harnesses.

Two harness assemblies are contained in the aft IEA distributor functions. These harness assemblies allow for plugging in the various assemblies making up the distributor portion of the IEA and provide two-channel redundancy. They are hardwire circuits interfacing the plug-in assemblies to each other and to the various input and output connectors on each end of the IEA.

#### 4.5.1.7 Data Bus Coupler.

Two data bus couplers are used to couple the primary and backup SRB data buses to the multiplexer interface adapters (MIA) in the MDM. The data bus coupler is a transformer device with a turns ratio of 1.4 to 1 and is used to impedance match SRB data buses to MIAs.

#### 4.5.1.8 BITE

The APU BITE circuitry has two basic functions during prelaunch checkout: (a) performs a resistance test on two control valves, fuel isolation valve, 2 MPUs, hydraulic pump solenoids, and the APU control valve solenoids, providing a discrete indication of the results and (b) injects a pulse train to simulate the MPU pulses for self-test of the APU controller: The circuits are interlocked to ensure that two of the three fuel control valves remain closed during the controller self-test. Each APU contains a separate BITE circuit; they are identical in operation.

### 4.5.2 Multiplexer/Demultiplexer (MDM) Function.

The MDM of the aft IEA encodes and multiplexes sensor data provided by the SRB subsystems. It also demultiplexes and decodes OV commands and interrogations from the OV to the SRBs. The MDM (shown in Figure 4-12 and 4-13) is redundant in that it can receive or transmit over either of two data buses designated as primary and backup. The MDM issues 5-volt discrete commands and accepts 0- or 5-volt and 0- or 28-volt discrete signals, and 0- to 5-volt analog signals. The MDM design accommodates two rows of nine solid-state plug-in assemblies forming redundant functional paths through the MDM. These assemblies are functionally oriented, and either functional path may receive or transmit information, commands, or data between the SRBs and the OV.

#### 4.5.2.1 MDM.

Four MDMs are used on the SRBs, with each IEA of each SRB containing an MDM. The MDMs are controlled by ground support equipment (GSE) prior to launch and the GPCs via the MEC after lift-off. Control is via bi-directional serial data buses that connect to the MIAs contained in each MDM.

The MDM is a functional package designed to be installed in each of the IEAs. The MDM modules are accessible by removing the IEA cover and then the MDM cover. Each MDM contains 18 plug-in modules of nine types, with two of each. With the exception of one power supply type, all modules are of the same general size and construction. Each module consists of two solid-state circuit boards mounted on a single frame, except for the core power supplies that have one circuit board. Interboard connection is by flex cables mounted at the top of the circuit boards.

Communication with the MDM is carried out via either data bus. Data transfer uses 28-bit words and a transfer rate of 1 megabit per second. Data transfer over each serial data bus is half-duplex, and only one data bus port of the MDM can be active at any time.

The nine types of plug-in modules contained in each MDM perform as the following functional elements: one core power supply, one input/output module power supply, one MIA, one sequence control unit (SCU), one analog to digital (A/D) converter, one direct current input differential (DCID)



module, one discrete input 28 volt (DIH) module, one discrete input 5 volt (DIL) module, and one discrete output 5 volt (DOL) module.

The power supplies are used to power the MDM. The SCU provides sequencing and control of the MDM, while the MIA processes the data bus signals received and transmitted. The A/D cards convert analog data to digital data and the DCID cards function to handle differential signals. The DIH and DIL cards receive and process appropriate discrete inputs, and DOL cards provide discrete output 5 VDC signals in response to OV commands to the SRBs.

#### 4.5.3 Signal Conditioner Functions.

The signal conditioners in the aft IEA accept signals from operational SRB flight instrumentation sensors and, condition these signals for input to the MDM. Also included are calibration signals used to calibrate SRM and TVC pressure transducers. Eleven printed circuit board-type plug-in assemblies are contained in the signal conditioner portion of the aft IEA. These are as follows: two power bus isolation supplies (PBISs), two amplifier buffer attenuators (ABAs), two converter pulse to direct current voltages (CPDs), two converter variable resistance to direct current voltages (CVRDs), one calibration card, and two harness assemblies.

##### 4.5.3.1 PBISs.

These PBIS assemblies are solid-state isolation power supplies used to provide redundant power to the signal conditioner circuits while maintaining isolation between the OV power buses.

##### 4.5.3.2 ABAs.

The ABA assemblies consist of four differential amplifiers operating with floating inputs and dual isolated outputs. These assemblies are capable of accepting analog inputs and provide dual isolated outputs of a positive ungrounded voltage in the range of 0 to 5 VDC directly proportional to the input analog signals.

##### 4.5.3.3 CPDs.

The CPD assemblies consist of converters that accept pulse train signals of variable pulse rate, amplitude, and input impedance and provide dual isolated outputs. The output signals will be in the range of 0 to 5 VDC and directly proportional to the change in pulse rate signal input. The CPDs will respond to 90 percent of total pulse rate change within 125 milliseconds.

##### 4.5.3.4 CVRDs.

The CVRD assemblies consist of resistance to DC converters operating with temperature transducer input signals and providing dual isolated outputs. The CVRD supplies excitation to the transducer from a precision power supply. The output will be in the range of 0 to 5 VDC directly proportional to the resistance values of the associated temperature sensors.

##### 4.5.3.5 Calibration Cards.

These assemblies provide circuitry used to calibrate SRM and TVC pressure transducers during prelaunch checkout of the SRB.

##### 4.5.3.6 Harness Assemblies.

These assemblies provide hardware circuitry connecting the signal conditioner assemblies to each other and to the respective input and output connectors at each end of the IEA.

#### 4.5.4 Pressure Transducer.

A single pressure transducer is included and is used only for pre-installation and post-flight checkout of the IEA to ensure the integrity of the cover seals. It is not monitored after the IEA is installed.

#### 4.6 FORWARD IEA PHYSICAL DESCRIPTION.

The forward IEA is similar in design and construction to the aft IEA. It is mounted on a structural ring in the watertight forward skirt compartment of each SRB. The forward IEA communicates with and receives power from the OV through the aft IEA, but has no direct electrical connection to the OV. With the exceptions of the APU controller, two recovery logic assemblies, and a current shunt, the remaining forward IEA assemblies are identical to those contained in the aft IEA. The forward IEA contains 39 plug-in assemblies. It has 14 connectors on the tunnel end and 13 connectors on the ET attach end. The complete forward IEA with its internal components weighs approximately 188 pounds.

#### 4.7 FORWARD IEA FUNCTIONAL DESCRIPTION.

The forward IEA provides the same three functional capabilities within the E&I subsystem as described for the aft IEA.

##### 4.7.1 Distributor Function.

The forward IEA distributor function provides distribution of electrical power to sensors, one channel of the range safety subsystem, SRB recovery aids, and one rate gyro assembly. The PICs, located in the distributor portion of the forward IEA, are used for SRM ignition, forward BSM ignition, forward SRB/ET attach separation, nose cap release, and frustum release.

The distributor function of the forward IEA is accomplished through the use of 20 plug-in assemblies and two cable harnesses: eight PICs, five switching cards, one miscellaneous component board, three recovery logic boards; two harness assemblies; and a recovery battery shunt.

##### 4.7.1.1 PICs.

The PICs are identical to those contained in the aft IEA. They detonate, on command, SRB ordnance devices used for ignition, separation, and all parachute deployments.

##### 4.7.1.2 Switching Cards.

Five switching cards are used to sequence various SRB functions. These cards are identical in function to those contained in the aft IEA.

##### 4.7.1.3 EMI Filters.

Two EMI filters identical to those in the aft IEA are used.

##### 4.7.1.4 Miscellaneous Component Boards.

One miscellaneous component board used in the forward IEA is identical in function to those contained in the aft IEA.

##### 4.7.1.5 Recovery Logic.

Three of these assemblies are used to sequence recovery operations. These are solid-state sequencing circuits and are contained only in the forward IEA.

##### 4.7.1.6 Current Shunt.

This current shunt permits monitoring of the recovery battery current.

#### 4.7.1.7 Harness Assemblies.

Two of these assemblies are used in the distributor function of the forward IEA. They are identical in function to the aft IEA harnesses.

#### 4.7.2 MDM Function.

The MDM of the forward IEA provides the same capability as that described for the aft IEA MDM, and circuitry is identical. Communication between this MDM and the OV, however, is via the aft IEA.

#### 4.7.3 Signal Conditioner Functions.

The signal conditioner functions of the forward IEA are identical to those described for the aft IEA. Eight plug-in assemblies are used in the signal conditioner portion of the forward IEA. These assemblies include two PBIS assemblies, two ABA assemblies, one calibration card, one CVRD assembly, and two harness assemblies.

#### 4.7.4 Pressure Transducer.

This assembly is identical to the aft IEA pressure transducer assembly (see Figure 4-14.)

#### 4.8 RATE GYRO ASSEMBLY (RGA).

Each RGA contains two orthogonally mounted gyroscopes (pitch and yaw axes) with auxiliary components. See Figure 4-15. The RGAs are mounted in the forward skirt watertight compartment. The E&I subsystem provides cabling necessary for the operation and monitoring of the RGAs, processes multiplexed commands from the LPS which are used in RGA functional testing and in switching of electrical power to one RGA. The second RGA is powered directly from the OV. The RGAs provide angular rate information that describes the inertial motion of the vehicle cluster to the OV control system.

#### 4.9 INSTRUMENTATION SENSORS.

Instrumentation sensors are provided to meet the requirements of the Operational Flight Instrumentation Program. These include pressure transducers for TVC hydraulics. SRM pressure transducers are furnished by the SRM contractor.

#### 4.10 ALTITUDE SWITCH ASSEMBLY.

The Altitude Switch Assembly (ASA) is mounted in the frustum and initiates the logic signals necessary for deployment of the drogue and main parachutes. Energizing of the recovery aids is also controlled by this switch. The ASA is sensitive to barometric pressure changes (static pressure) with an accuracy of 300 feet change. The ASA initiates release of the nose cap, and deployment of pilot and drogue parachutes at an altitude of approximately 16,000 feet. It also initiates release of the frustum and deployment of the main parachutes at approximately 6,000 feet. Two switching circuits are used in initiating the pressure/altitude-triggered events. One switch (Hi Baro) detects the 16,000-foot altitude pressure condition, and the second switch (Lo Baro) detects the 6,000-foot altitude pressure. The second switch circuit provides a signal to separate the nozzle extension. This assembly is further described in Section 7.0.

#### 4.11 CABLE ASSEMBLIES AND CIRCUITS.

The cables used in each SRB are of the reusable and the throwaway types. The reusables may be watertight or non-watertight, and they carry the letter "R" behind the reference designator, with the exception of the FWD Tunnel and Aft Skirt to IEA cables that have been reclassified as expendable.

Throwaway cables are alternates for reusable cables in the aft skirt. The OF cables are as follows: watertight, 38; non-watertight, 46; and throwaway, 32. The reusable cables are capable of 20 uses in ocean depths to 125 feet and to elevations up to 210,000 feet above sea level.

The SRB cables are used for two different functions; power and signals. The signals susceptible to electromagnetic interference (EMI) require cables with a metallic shield. Radio frequency signals require coaxial cables.

Where an overall shield is required, the shield is constructed of braided copper strands per ASTM B355 and has a minimum of 50-microinches of nickel coating. The overall shield is applied over the assembled cabling to provide a minimum of 90% coverage. The shields of small cables comprised of single groups of twisted, shielded, and jacketed conductors are considered overall shields.

A jacket of commercial grade, translucent, non-reverting, abrasion-resistant, tubular polyurethane material is applied to a snug fit over the cable conductors or overall shield as applicable.

#### 4.12 SUBSYSTEM REDUNDANCY.

The E&I subsystems have simplex, dual, triplex, and quadruplex functions incorporated on each SRB. OFI includes the redundancy necessary to ensure that no single failure results in loss of SRB system visibility to the orbiter or in loss of SRB function receiving multiplexed commands.

- a. Simplex.
  1. E&I components of the recovery subsystem, except that redundancy shall be incorporated to prevent premature drogue deployment, main chute deployment, and nozzle jettison during ascent.
  2. SRM safe and arm (S&A) device control.
- b. Dual. The following are redundant:
  1. SRM ignition initiation.
  2. SRB/ET separation control.
  3. Power to flight instrumentation.
  4. Hydraulic power system control.
- c. Triplex. The SRM chamber pressure measurements are triplex.
- d. Quadruplex. The rate gyroscope system power and output functions and the TVC actuator control and servoactuator differential pressure measurement signals are quadruplex. The OV GPCs treat the four RGAs (2 in each SRB) as a quadruplex system.

#### 4.13 INSTRUMENTATION AND SIGNAL CONDITIONERS

##### 4.13.1 Wideband Signal Conditioner (WBSC) Unit.

Two WBSC units are used for conditioning vibration measurements and other broadband measurements, such as pressure and strain.

#### 4.13.2 Dedicated Signal Conditioner.

The dedicated signal conditioner (DSC) accommodates a mix of input signals by an interchange of plug-in modules. The signal conditioner performs the following functions:

- a. Conditions to level, form, and mode pickup point signals and transducer signals that are inputs to PCM and IEA MDM.
- b. Provides buffering and isolation.
- c. Provides a precision power supply to be used for sensor excitation.

The dedicated signal conditioner may include any mix of the following modules:

- a. any DC amplifiers, attenuators and analog buffers.
- b. AC to DC voltage converters.
- c. Variable resistance to DC voltage converter.
- d. Pulse to DC voltage converters.
- e. Discrete buffers.

#### 4.13.3 Pressure Sensors.

Several types of pressure sensors are used on the SRB. These types are as follows:

- a. Servoactuator Differential Pressure Sensors. These are built into the actuator and have a range of plus or minus 5000 PSI.
- b. Static Pressure Sensors. Static pressure sensors with a range of 0 to 10 psi are mounted on the SRB and SRM components. The sensors mounted on the SRM motor segments are provided by the SRM contractor.
- c. Dynamic Pressure Sensors. Higher range pressure sensors are used to monitor Hydrazine and Hydraulic fluid pressures to 4000 PSIA in the TVC subsystem.
- d. Igniter Chamber and SRM Chamber Pressure Sensors. The igniter and SRM chamber pressure sensors have a range of 0 to 3000 PSIA and 0 to 1000 PSIA, respectively. The SRM contractor will furnish these sensors.

#### 4.13.4 Temperature Sensors.

Differing types of temperature sensors are used in SRB subsystems.

- a. Temperature Sensors consisting of Thermistors with a range of 32 F to 140 F or platinum Resistance Temperature Devices (RTDs) with a range of -150 F to +750 F are utilized to monitor surface temperatures.
- b. Gas Temperature Sensors consist of fast-response thermocouples used to monitor hot gas temperatures up to 2,500 F.

#### 4.13.5 Current Sensors.

Recovery battery current flows are monitored via current shunts.

#### 4.13.6 Voltage Sensors.

Recovery battery voltages are monitored via voltage dividers.

#### 4.13.7 Camera Subsystem.

The camera subsystem is used to obtain motion picture coverage of the deployment of the SRB main parachutes. For more information, see Section 7.0, Solid Rocket Booster Recovery subsystem.

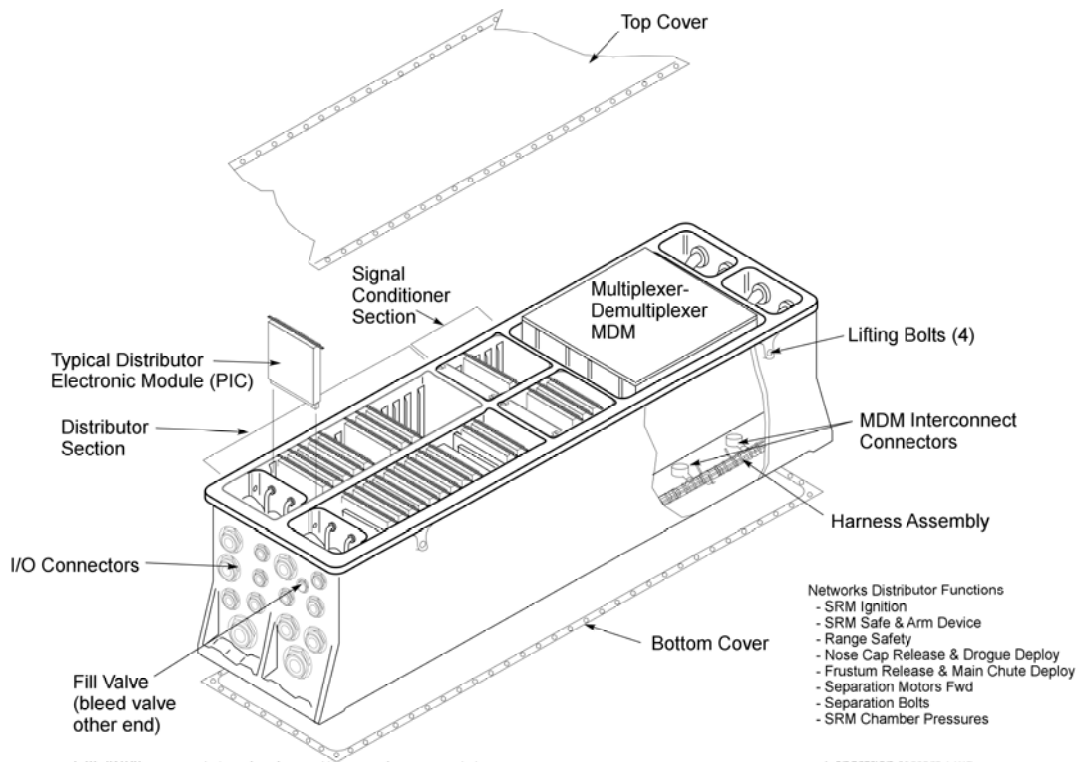

Figure 4-3. Typical IEA Assembly Components

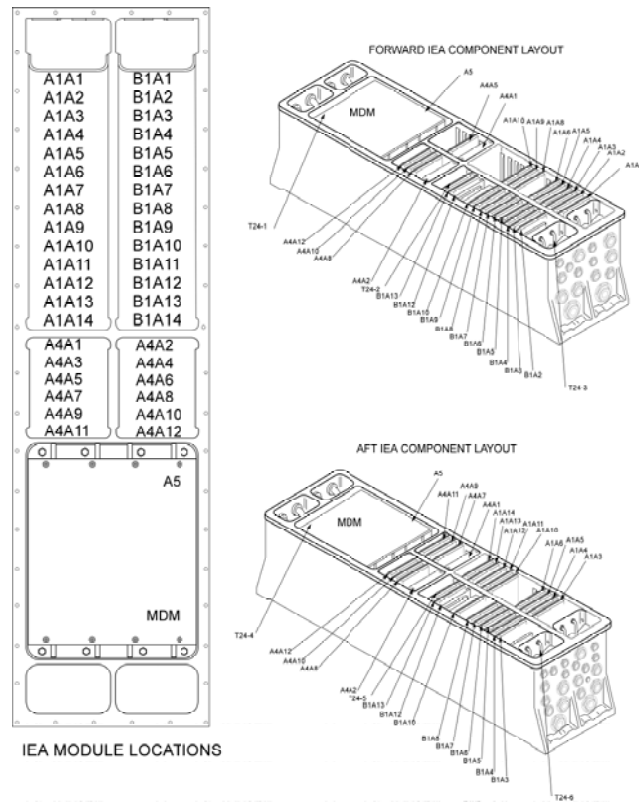

Figure 4-4. IEA Component Locations and Description

**TABLE 4-1. Forward IEA Unit, List of Major Assemblies**

Ref. Des.No.	Assembly	Canton Name	Part No.
	SRB Forward Integrated Electronics Assy	Forward IEA	5080004-215
AI	-	Distributor	-
1A1	0.5 Amp Combination Switch Driver Circuit Card Assy	0.5A-Combination Switch Card	5100081-4
A1A2	0.5 Amp Combination Switch Driver Circuit Card Assy	0.5A-Combination Switch Card	5100081-4
A1A3	Pyrotechnic Initiator Controller Circuit Card Assy	PIC Card	5104115-10
A1A4	3-Amp, 5-Volt switch Driver Circuit Card Assy	3A-5V Switch Card	5100021-4
A1A5	Pyrotechnic Initiator Controller Circuit Card Assy	PIC Card	5104115-10
A1A6	Pyrotechnic Initiator Controller Circuit Card Assy	PIC Card	5104115-10
A1A7	Not used		
A1A8	Miscellaneous III Circuit Card Assy	Misc. III Card	5100525-1
A1A9 thru A1A14	Not used		
B1	-	Distributor B	-
B1A1	Not used		
B1A2	0.5-Amp, 28 Volt Switch Driver Circuit Card Assy	0.5A-28V	5100060-4 Switch Card
B1A3	Pyrotechnic Initiator Controller Circuit Card Assy	PIC Card	5104115-10
B1A4	3-Amp, 5-Volt switch Driver Circuit Card Assy	3A-5V Switch Card	5100021-4
B1A5	Pyrotechnic Initiator Controller Circuit Card Assy	PIC Card	5104115-10
B1A6	Pyrotechnic Initiator Controller Circuit Card Assy	PIC Card	5104115-10
B1A7	0.5-Amp, 5 Volt Switch Driver Circuit Card Assy	0.5A-5V Switch Card	5100022-4
B1A8	Recovery Logic III Circuit Card Assy	Recovery Logic III	5100559-1 Card
B1A9	Recovery Logic IA Circuit Card Assy	Recovery Logic	5100523-1 IA Card
B1A10	Recovery Logic IIC Circuit Card Assy	Recovery Logic	5100724-1 IIC Card
B1A11	Not used		
7B1A12	Pyrotechnic Initiator Controller Circuit Card Assy	PIC Card	5104115-10
B1A13	Pyrotechnic Initiator Controller Circuit Card Assy	PIC Card	5104115-10
A2	Data Bus Coupler	DBC A	5104117-1
A3	Data Bus Coupler	DBC-B	5104117-1
A4	-	Signal Conditioner	-
A4A1	Power Bus Isolation Supply Circuit Card Assy	PBIS Card	5106627-2
A4A2	Power Bus Isolation Supply Circuit Card Assy	PBIS Card	5106627-2
A4A3 and A4A4	Not used		
A4A5	Signal Conditioner Calibration circuit Card Assy	Cal. Card	5100028-1 or 5100528-1
A4A6 and A4A7	Not used		
A4A8	DC Amplifier-Buffer Attenuator Circuit Card Assy	ABA Card (0-50 mV)	5104119-3
A4A9	Not used		
A4A10	DC Amplifier-Buffer Attenuator Circuit Card Assy	ABA Card (0-40 mV)	5104119-4
A4A11	Not used		
A4A12	Converter, Variable Resistance to DC Circuit Card Assy	CVRD Card	5104120-1
A5	Multiplexer/Demultiplexer	MDM	5104116-7
A6	Pressure Transducer	Pressure Transducer	5157017-1
A7	EMC Filter Module	EMC Filter (A)	5107276-1
A8	EMC Filter Module	EMC Filter (B)	5107276-1
A9	Not used		
A10	Recovery Shunt-Channel B	Recovery Shunt	5154024-1
All	Resistor Terminal Board	Terminal Board	5109175-1
A12	Terminal Board and Component Assembly	Terminal Board	5106984-1
A13	Resistor Terminal Board	Terminal Board	5109175-1
T24-1, -2, -3	Temperature Sensor	Temperature Sensor	5157018-1
-	Harness Assy, Channel A	Harness Assy (A)	5104127-5
-	Harness Assy, Channel B	Harness Assy (B)	5104128-8
-	Signal Conditioner Harness Assy, Channel A	Signal Conditioner Harness (A)	5104124-4
-	Signal Conditioner Harness Assy, Channel B	Signal Conditioner Harness (B)	5104125-4
-	Top Cover & Gasket Assy	Top Cover	5104949-1
-	Bottom Cover	Bottom Cover	5158151-1



**TABLE 4-2. Aft IEA Unit, List of Major Assemblies**

Ref.Des.No.	Assembly	Common Name	Part No.
	SRB Aft Integrated Electronics Assy	Aft IEA	5080005-311
A1		Distributor A	
A1A1 and A1A2	Not used		
	0.5 Amp Combination Switch Driver Circuit Card Assy	0.5A Combination Switch Card	5100081-4
A1A4	Pyrotechnic Initiator Controller Circuit Card Assy	PIC Card	5104115-10
A1A5	Pyrotechnic Initiator Controller Circuit Card Assy	PIC Card	5104115-10
A1A6	Pyrotechnic Initiator Controller Circuit Card Assy	PIC Card	5104115-10
A1A7	Pyrotechnic Initiator Controller Circuit Card Assy	PIC Card	5104115-10
A1A8 and A1A9	Not Used		
A1A10	Miscellaneous IV Circuit Card Assy	Misc. IV Card	5100759-2
A1A11	3-Amp Combination Switch Driver Circuit Card Assy	3A-Combination Switch Card	5100082-5
A1A12	3-Amp, 5 -Volt Switch Driver	3A-5V Switch Card	5100021-4
A1A13	Circuit Card Assy APU Controller Circuit Card Assy	APU Controller Card	5104118-5 Card
A1A14	APU Bite Module	APU Bite Module	5105265-2
B1	-	Distributor B	-
B1A1and B1A2	Not used		
B1A3	0.5 Amp Combination Switch Driver Circuit Card Assy	0.5A-Combination Switch Card	5100081-4
B1A4	Pyrotechnic Initiator Con-	PIC Card	5104115-10
B1A5	Pyrotechnic Initiator Controller Circuit Card Assy	PIC Card	5104115-10
B1A6	Pyrotechnic Initiator Controller Circuit Card Assy	PIC Card	5104115-10
B1A7	Pyrotechnic Initiator Controller Circuit Card Assy	PIC Card	5104115-10
B1A8	Pyrotechnic Initiator Controller Circuit Card Assy	PIC Card	5104115-10
B1A9	Not Used		
B1A10	Miscellaneous IV Circuit Card Assy	Misc. IV Card	5100759-2
B1A11	3-Amp Combination Switch Driver Circuit Card Assy	3A-Combination Switch Card	5100082-5
B1A12	3-Amp, 5 -Volt Switch Driver	3A-5V Switch Card	5100021-4
B1A13	APU Controller Circuit Card Assy	APU Controller	5104118-5 Card
B1A14	APU Bite Module	APU Bite Module	5105265-2
A2	Data Bus Coupler	DBC A	5104117-1
A3	Data Bus Coupler	DBC-B	5104117-1
A4	-	Signal Conditioner	-
A4A1	Power Bus Isolation Supply Circuit Card Assy	PBIS Card	5106627-2
A4A2	Power Bus Isolation Supply Circuit Card Assy	PBIS Card	5106627-2
A4A3 and A4A4	Not used		
A4A5	Signal Conditioner Calibration Circuit Card Assy	Cal. Card	5100028-1 or 5100528-1
A4A6	Not used		
A4A7	Converter, Pulse to DC, Circuit Card Assy	CPD Card (0-4 kHz)	5104284-1
A4A8	Converter, Pulse to DC, Circuit Card Assy	CPD Card (0-4 kHz)	5104284-1
A4A9	Converter, Variable Resis-tance to DC, Circuit Card Assy	CVRD Card (32F(0C) -140F(60C))	5104120-1
A4A10	Converter, Variable Resistance to DC, Circuit Card Assy	CVRD Card (0F(-18C) - 250F(121C))	5104120-2
A4A11	DC Amplifier-Buffer-Attenuator Circuit Card Assy	ABA Card (0-40 mV)	5104119-2
A4A12	DC Amplifier-Buffer-Attenuator Circuit Card Assy	ABA Card (0-30 mV)	5104119-1
A5	Multiplexer/Demultiplexer	MDM	5104116-7
A6	Pressure Transducer	Pressure Transducer	5157017-1
A7	EMC Filter Module	EMC Filter	5107276-1
AS	EMC Filter Module	EMC Filter	5107276-1
A9 thru A11	Not used		
T24-4, -5, -6	Temperature Sensor	Temperature Sensor	5157018-1
-	Harness Assy-Channel A	Harness Assy (A)	5104122-5
-	Harness Assy-Channel B	Harness Assy (B)	5104123-5
-	Signal Conditioner Harness-Channel A	Signal Conditioner Harness (A)	5104124-4
-	Signal Conditioner Harness-Channel B	Signal Conditioner Harness (B)	5104125-4
-	Top Cover & Gasket Assy	Top Cover	5104949-1
-	Bottom Cover	Bottom Cover	5158151-1

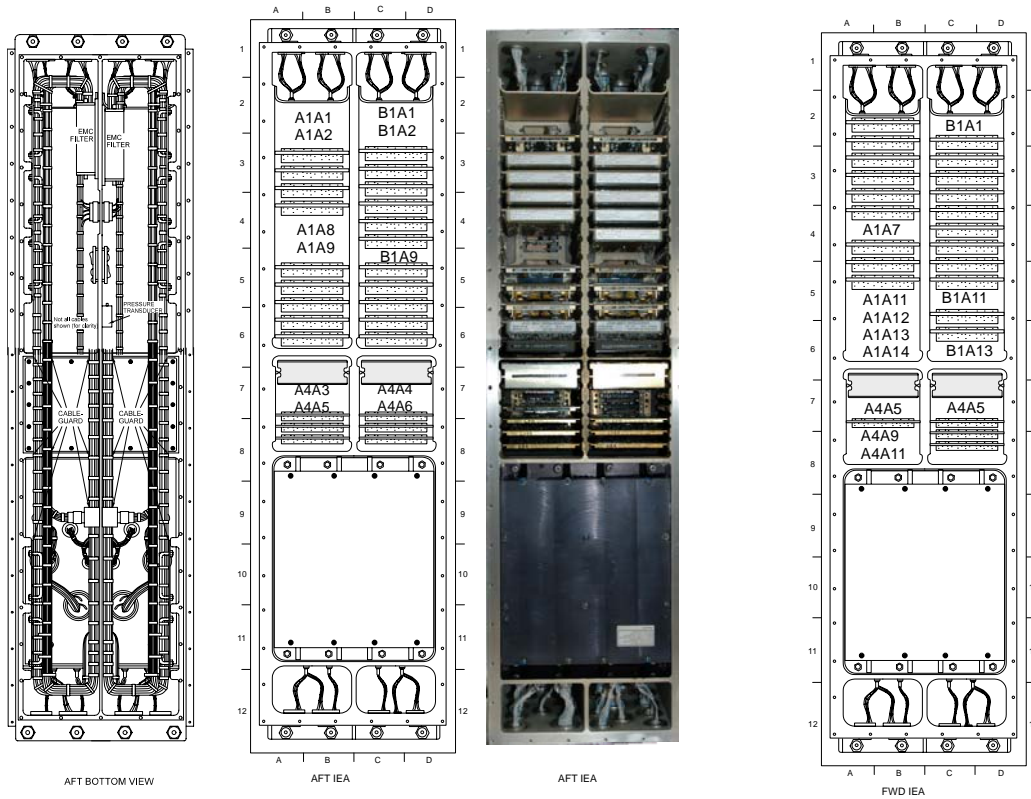

Figure 4-5. IEA Components Showing Current Flight Configuration.

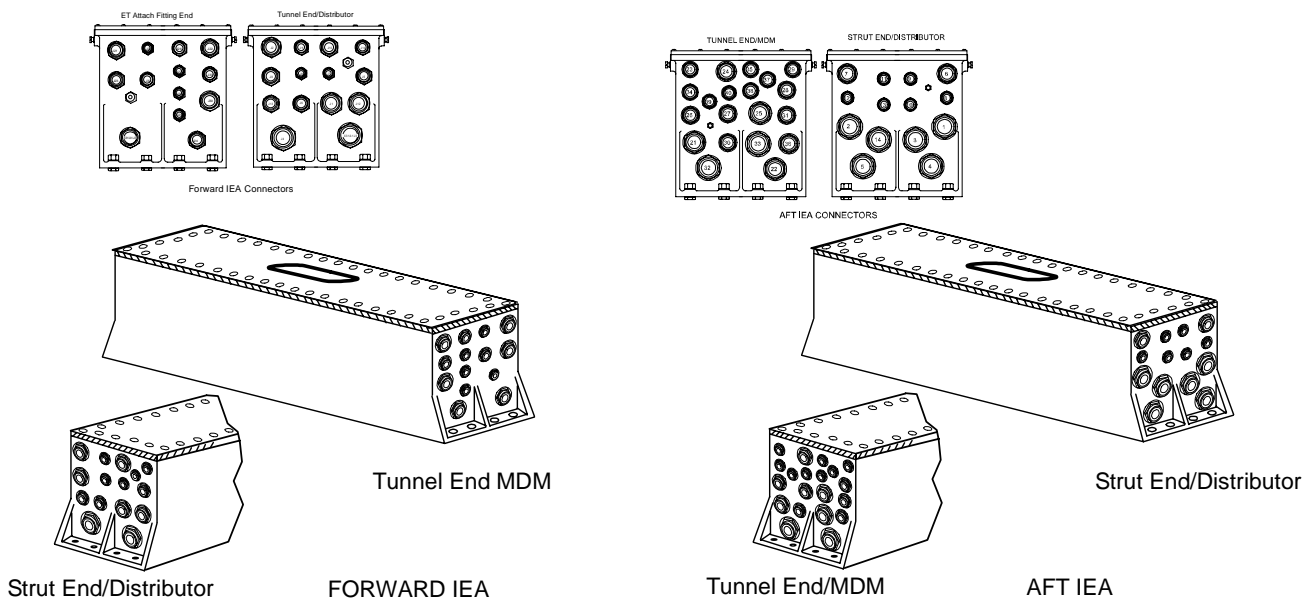

Figure 4-6. IEA Connector Arrangement for Forward and Aft Assemblies



Figure 4-7. IEA Aft Connector Images (typical)

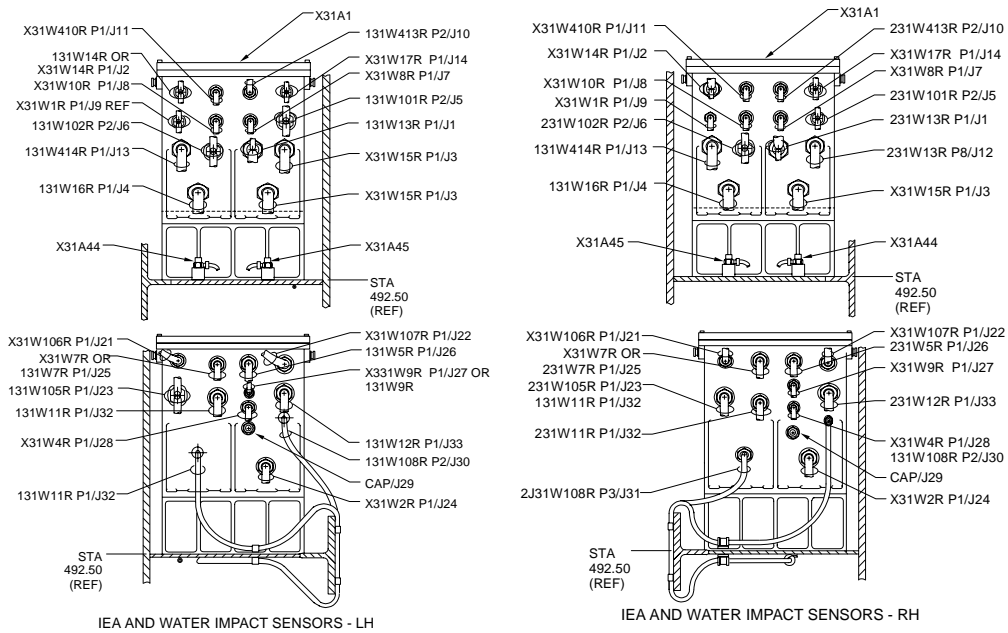

Figure 4-8. Integrated Electronics Assembly (IEA) Water Impact Sensors

TABLE 4-3. Leading Particulars for IEAs

Characteristic	Description	
	FWD IEA	AFT IEA
Dimensions		
Length	45.000 in.	45.000 in.
Width	11.035 in.	11.035 in.
Height	12.750 in.	12.750 in.
Volume	4874 cu. In.	
Weight	184 lbs.	194 lbs.
Power Requirements (Nominal) (three isolated buses Supplied from OV)	28 VDC 113 watts (max.)	28 VDC 151.4 watts (max.)
Environmental Requirements		
Operating	N/A – Sealed Units	
Maintenance and Storage		
Temperature	65 F to 80 F (18 C to 27 C)	
Relative Humidity	50% (max)	

The forward and aft IEAs are rectangular, box shaped, pressurized assemblies containing the electronic circuits and interconnecting wiring required to accomplish the functional purpose of the unit. Although similar in appearance, the forward and aft IEA assemblies are not interchangeable with one another. However, assemblies with the same part number are interchangeable.

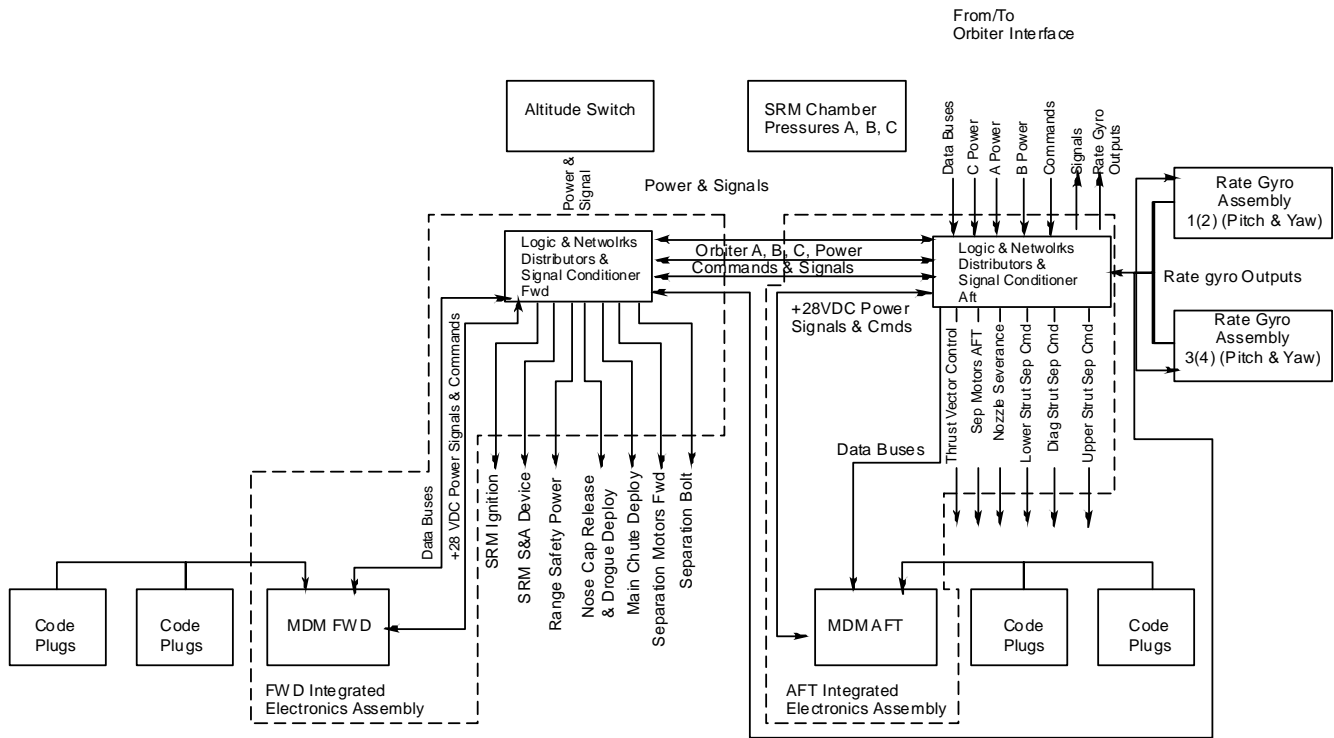

Figure 4-9. Electrical and Instrumentation (E&I) Subsystem Functional Diagram

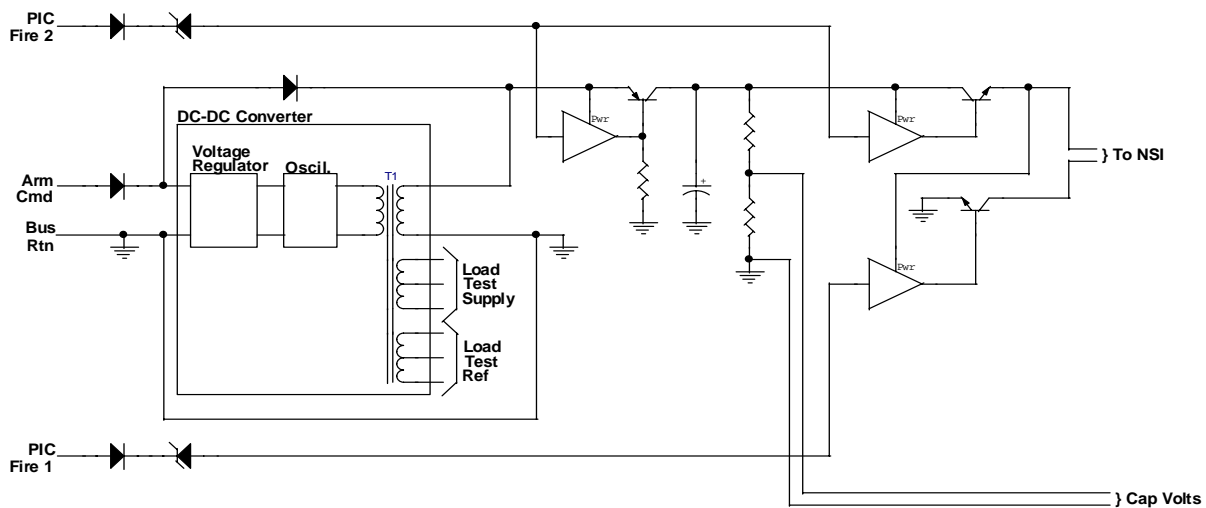

Figure 4-10. PIC Simplified Schematic

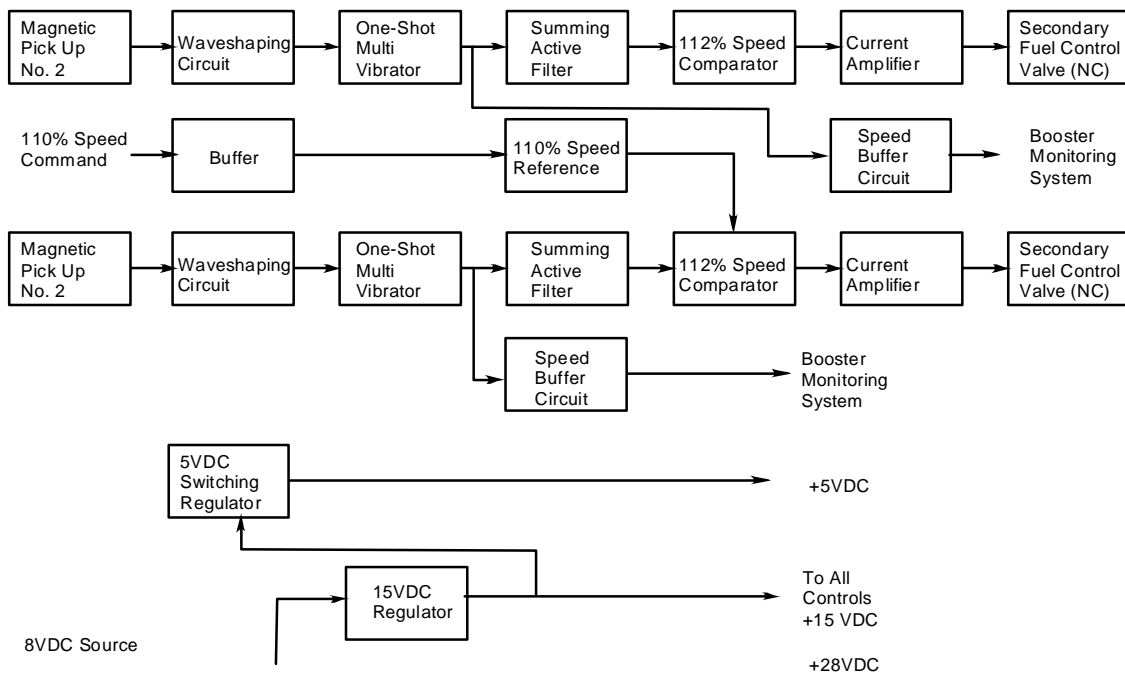

Figure 4-11. SRB TVC APU Controller

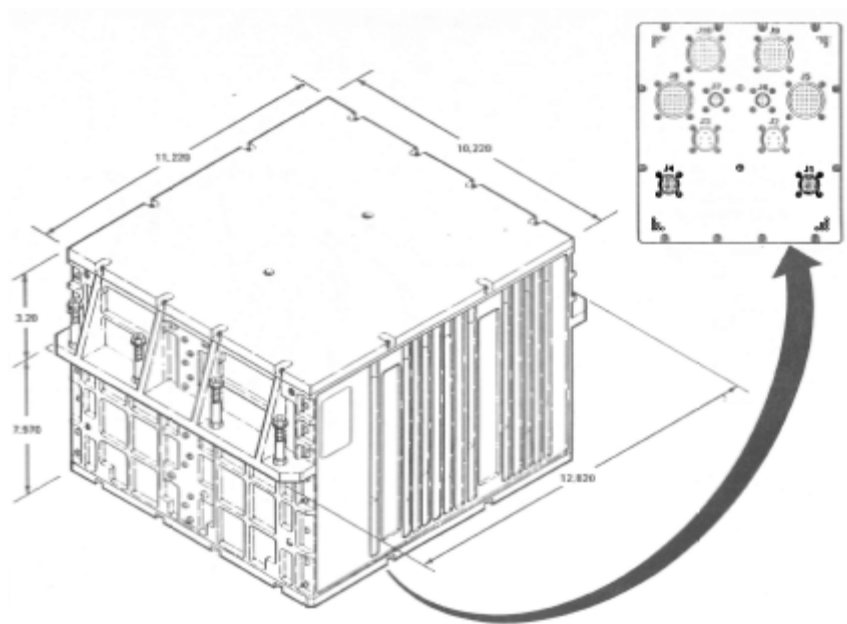

Figure 4-12. SRB MDM Connectors

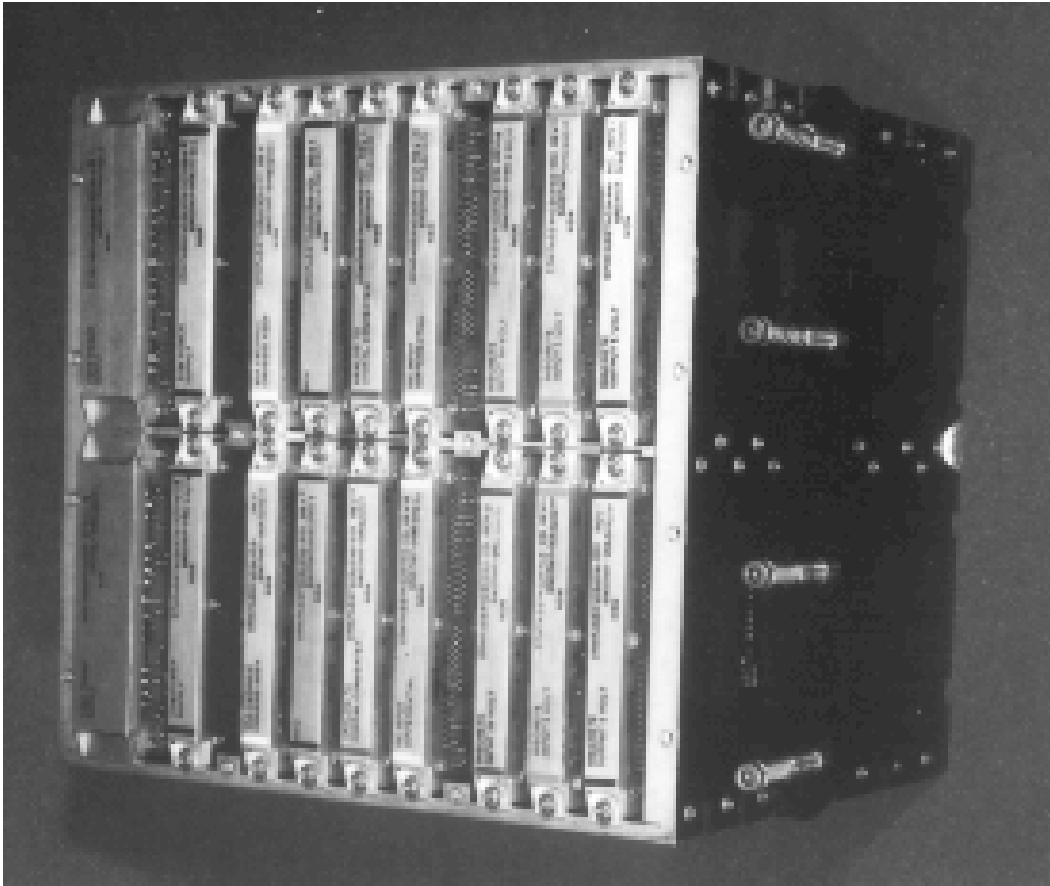

Figure 4-13. SRB MDM Component Pictures

TABLE 4-4 Module Complement

<u>Input Type</u>	Capacity
DC Analog Input	64 Channels
Discrete Input (5V)	96 Bits
Discrete Input (28V)	96 Bits

<u>Output Type</u>	Capacity
Discrete Output (5V)	96 Bits

Size	11" x 10" x 8"
Weight	33 lb. max.
Power	51 to 78.5 watts

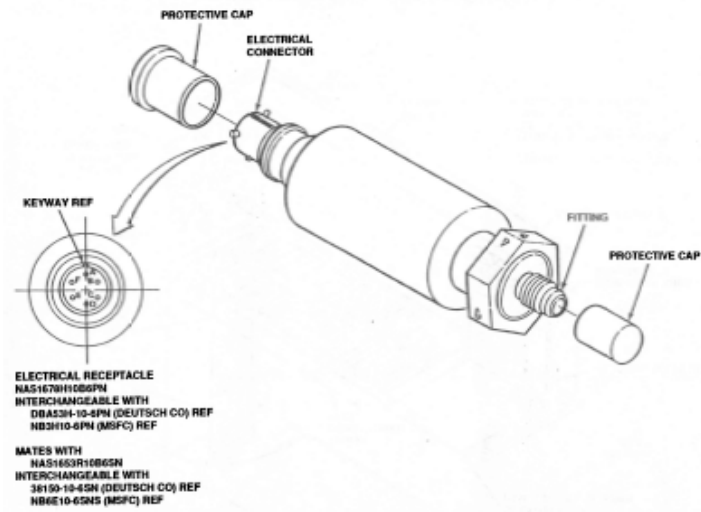
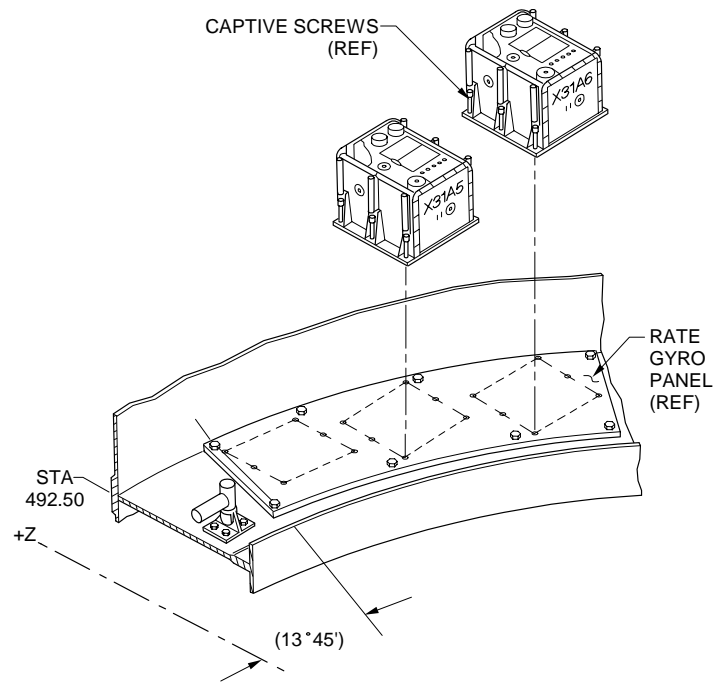

Figure 4-14. SRM Chamber Pressure Transducer



RH FORWARD SKIRT - RATE GYRO REMOVAL

Figure 4-15. Rate Gyroscope Assemblies (Right Hand)

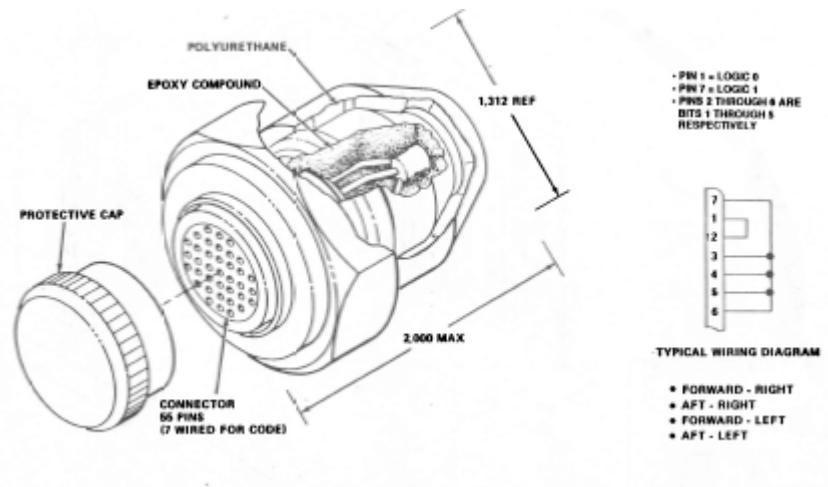

Figure 4-16. IEA/MDM Code Plug



Figure 4-17. SRB Data Acquisition System



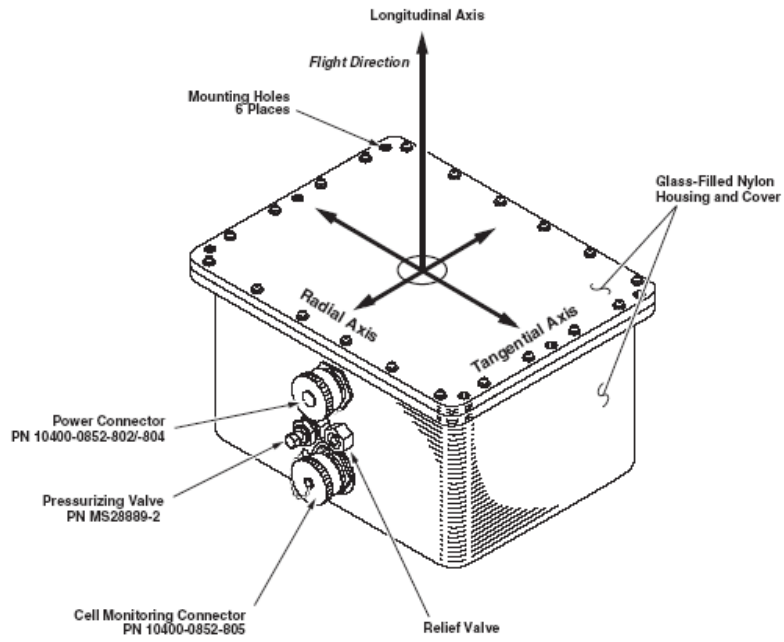

Figure 4-18. SRB Data Acquisition System

## 5.0 SOLID ROCKET BOOSTER THRUST VECTOR CONTROL SUBSYSTEM

### 5.1 GENERAL DESCRIPTION.

The thrust vector control (TVC) subsystem, in conjunction with the SRM provides pitch, roll, and yaw moments as required by the orbiter attitude control systems. The TVC subsystem, located in the SRB aft skirt, consists of two separate hydraulic power units (HPUs) that supply hydraulic power to the TVC electro-hydraulic servoactuators to effect mechanical positioning of the SRB nozzle in response to steering commands. One HPU controls the nozzle position in the tilt plane; the other HPU controls the nozzle position in the rock plane. If a single HPU fails, the surviving HPU increases its hydraulic power output and controls the nozzle position in both the rock and tilt planes at a slightly degraded nozzle gimbal velocity (3°/sec vs. 5°/sec). The servoactuators are designed to retain the nozzle in the null position throughout the SRB/ET separation sequence until SRB water entry. These servoactuators are oriented outboard from the ET, 45° to the Y-axis of each SRB. Figures 5-1 through 5-4 show various levels of detail for the TVC system as installed in the aft skirt. Figure 5-5 shows the external structure of the aft skirt and the TVC access ports.

The HPU is driven by an auxiliary power unit (APU). The APU is a hydrazine (N<sub>2</sub>H<sub>4</sub>) powered, single stage, axial flow impulse, reentry type turbine which drives the hydraulic pump through the gearbox to provide a pressurized fluid flow to the servoactuator where it is controlled to obtain the proper nozzle positioning. Figure 5-6 is a schematic of the hydraulic control, where details of the “Rock” actuator are shown specifically. The hydraulic power unit is comprised of the following subassemblies:

- a. Fuel supply module (FSM)
- b. Fuel filter
- c. Fuel isolation valve (FIV)
- d. Auxiliary power unit (APU)
  1. Fuel pump
  2. Gas generator valve module  
Pulse (primary) control valve (normally open) Shutoff (secondary) control valve (normally closed)
  3. Gas generator  
Injector stem  
Catalytic bed heaters  
Catalytic decomposition chamber
  4. Turbine
  5. Magnetic pickup (speed sensor) unit (MPU)
  6. Gearbox
- e. Gearbox pressure equalization device
- f. Hydraulic pump
- h. Hydraulic fluid manifold
- i. Hydraulic fluid check valve and filter assembly
- j. APU controller
- k. Lines, fittings, quick disconnects, valves, sensors, filters, and subsystems service panels
- l. Accumulators (MB, Parker, Lube Oil)
- m. Hydraulic Bootstrap Reservoir

The TVC subsystem is instrumented to measure catalytic bed temperature, turbine speeds, hydraulic and gas pressures, reservoir level, and mechanical switch positions. After the initial START commands

are transmitted from the launch processor system (LPS) via the MDM, the TVC subsystem is controlled by the APU controller assembly located in the aft IEA in each SRB. After lift-off, all command and control functions of the TVC subsystem originate in either the GN&C computers or the ascent TVC electronics of the OV. The OV ascent TVC electronics contain fault detection, isolation, and recovery (FDIR) functions for the SRB servactuators.

## 5.2 TVC SUBSYSTEM OPERATIONAL SEQUENCE.

Functions that affect the HPUs are initiated at T-9 hours in the launch countdown sequence when the fuel pump bearing soak begins. The gas generator catalyst bed heaters are energized at T-2 hours. The gas generator catalyst beds are temperature controlled to 190 to 248°F. One of two heaters on each gas generator is energized and is manually cycled to reach and maintain the gas generator catalyst bed temperature. Although two heater elements are located in each catalyst bed, only one heater element may be used at any time.

The temperature of each fuel supply module (FSM) is monitored during launch countdown to assure that the hydrazine remains at or above 45°F to prevent freezing. There are no heaters provided for the hydrazine, but measures can be taken to provide a flow of warm gaseous nitrogen (GN<sub>2</sub>) in the aft skirt. Also, the hydraulic reservoir fluid level is monitored for proper level. At T-31 seconds, the GN<sub>2</sub> pressure of both FSMs is monitored by the launch processing system (LPS) for pressurization, of 325 to 425 PSIA. A minimum hydraulic fluid level of 65-75% in the bootstrap reservoir is verified at T-9 minutes in the launch count and a minimum of 50 percent is necessary to continue the countdown sequence after T-31 seconds. At T-31 seconds, START commands are issued which open the fuel isolation valve and hydraulic pump bypass on both subsystems. These events are monitored via MDM (for data only). Operation of the isolation valve permits hydrazine, under GN<sub>2</sub> pressure, to flow through the normally open primary speed control valve to the normally closed secondary speed control valve in each APU.

At T-28 seconds, a command from the LPS via the MDM, the HYD SYS A2 & B2 START CMD, energizes the APU controller assemblies A & B in the aft IEA of each SRB. The APU controller assemblies' commands open the normally closed secondary speed control valves in each HPU. Also this valve actuation is monitored via the MDM for data only.

Opening of the secondary speed control valve allows hydrazine, under GN<sub>2</sub> pressure, to enter the APU gas generator catalytic decomposition chamber. The gear type fuel pump integral to the APU is initially bypassed. As the hydrazine flows across the preheated gas generator catalyst bed, it decomposes rapidly and forms a high pressure, hot gas that begins to drive the high-speed APU gas turbine. As the turbine speed increases, the fuel pump output pressure increases. When the fuel pump output pressure exceeds the N<sub>2</sub>H<sub>4</sub> pressure at the pump inlet, the fuel pump bypass-valve closes to allow the fuel pump to deliver N<sub>2</sub>H<sub>4</sub> to the gas generator. The turbine is designed to reach nominal speed (72,000 RPM) within a maximum of four seconds after initial fuel flow. The hot gas enters the turbine through the turbine primary inlet and is turned to reenter the turbine through twelve secondary inlets before being exhausted overboard through the turbine exhaust ducting.

As turbine speed increases, it is monitored by two magnetic pickup units (MPUs) located in proximity to the turbine shaft. Proper RPM buildup is required to continue the launch sequence. Turbine RPM is monitored until T-0 seconds (and into flight), and violation of specified limits will cause a launch sequence abort. At T-23 seconds in the countdown sequence, the HYP PUMP BYPASS VLV OPEN OFF commands are issued by the LPS via the MDMs. These commands remove the energizing voltage

from the pump bypass valve, returning it to the normally-closed status, and the hydraulic pump begins to pressurize the closed-loop HPU subsystem.

Turbine speed measurements are routed to the APU controller assemblies A and B for turbine speed control. Speed control is maintained within 8 percent of rated speed and is effected through the "bang-bang" (fully open or fully closed) operation of the primary speed control valve by the APU controller assemblies A and B, controlling the fuel flow to each of the turbines. Under normal operation, the turbine operates at a speed of 72,000 RPMs (100 percent speed) and delivers a shaft output of 135 horsepower to the hydraulic pump drive shaft.

Simultaneously with this speed monitoring and control, the hydraulic pressure of each HPU system is monitored via the SRB MDMs and the LPS. This monitoring of each HPU system's hydraulic pressure begins at T-15 seconds and continues until T-10 seconds. Deviations from specified HPU pressure value (2800 PSIG MIN/3363 PSIG MAX) during this time period will cause a launch sequence abort. The "Pressure O.K." pressure switch within each of the two servoactuators is pressure-actuated by a shift in the actuator switching valve which occurs when actuator supply hydraulic pressure drops and its position is monitored by the APU controller assemblies. When the HPU is providing rated pressure, the pressure switch is in the Primary (PRI) position (switch closed). HPU internal pressure decline to the range of 2,200-to 1,900 pounds per square inch (psi) signifies a malfunction within the HPU: The pressure switch will open, and this will be immediately sensed by the APU controller assemblies. This change in switch position will initiate a contingency mode of operation for the TVC subsystem. This mode of operation is further described under Contingency Modes.

At rated turbine speed (72,000 RPMs), the HPU pumps provide a rated discharge pressure of  $3,200 \pm 50$  pounds per square inch, gage (PSIG) under no-flow conditions. During TVC command intervals, the discharge rated pressure decreases to  $3,050 \pm 50$  PSIG while the variable delivery control within the hydraulic pumps position the wobble plates to produce a hydraulic fluid flow rate of 63 gallons per minute (GPMs) within 150 milliseconds. When the hydraulic demand on the TVC subsystem ceases, the wobble plate is repositioned to the no-flow state.

The TVC subsystems are designed to operate at 100 percent APU turbine rated speed from approximately T-26 seconds in the countdown sequence through the powered flight of the SRB. Capability exists to operate both servoactuators from only one HPU, and this is discussed under Contingency Modes. At 1.7 seconds prior to separation, both servoactuators in each SRB are commanded to the null position. The electrical power supplied to both of the HPUs is terminated at separation. The total operating time for each HPU is approximately 150 seconds.

### 5.3 CONTINGENCY MODES.

Two modes of contingency operation are provided for each of the HPUs in each of the SRBs. These are designated as 110 percent and 112 percent operating capabilities, which are programmed by the APU controller assemblies A and B for the respective HPUs. Both designations are percentages of turbine nominal speed initiated to compensate for specific subsystem failure modes. Both modes permit the effective operation of the TVC subsystem through the remaining HPU.

#### 5.3.1 110 Percent Operation.

Operation at 110 percent is initiated when the "pressure O.K." switch opens, which indicates low hydraulic pressure on the opposite subsystem. MPU #1 provides the turbine speed input to the controller for 100 percent and 110 percent operation. The APU controller assembly A or B

immediately commands the second HPU to operate at the 110 percent speed level. This is accomplished by increasing the fuel flow to the turbine by opening the primary speed control valve more often during the "bang-bang" operation, while controlling the turbine speed to 110 percent of nominal RPMs. This operation will remain in effect until the 100 percent signal is restored or until the end of the SRB powered flight. Over pressurization is compensated for by the hydraulic pump wobble plate, and the speed control is maintained by the appropriate APU controller assembly A or B. It is possible that the HPU can revert to 100 percent speed operation in the event the pressure in the primary subsystem returns to normal and both HPUs will resume powering the TVC subsystem. At the 110 percent operating mode, the APU delivers from 9 to 148 horsepower and the TVC subsystem is capable of providing responses to flight control commands, but at a reduced actuator gimbal rate.

#### 5.3.2 112 Percent Operation.

Operation at 112 percent is dictated by the apparent loss of APU control, indicated by turbine speed increases beyond the 110 percent mode. At 112 percent operation, the primary speed control valve is not necessarily disabled and may attempt to operate, but the secondary speed control valve exercises turbine speed control. As in the case of 110 percent operation, over-pressurization is compensated for by the hydraulic pump wobble plate. Once 112 percent operation is initiated by either APU controller assembly A or B, the affected APU will operate at 112 percent for as long as the primary speed control valve malfunction exists. When the primary speed control valve malfunction no longer exists, the affected APU will return to 100 percent operation. No system degradation in response capability should occur unless there is an intermittent failure of the primary valve.

#### 5.4 GIMBAL CAPABILITY.

Explanation of the SRB gimbaling capability requires a brief discussion of the SRB nozzle and flexible bearing. The SRB nozzle is a convergent/divergent movable design contained in an aft pivot point flexible bearing. This bearing consists of a flexible core constructed as a laminated structure made up of 10 spherical D6AC steel shims and 11 elastomer pads contained by two D6AC steel end rings and thermally protected by a flexible silica-filled NBR boot. The end rings and shims absorb applied loads, constrain the SRB nozzle, and permit gimbaling of the nozzle in response to commands issued to the rock and tilt actuators.

Construction of the flexible bearing constrains the nozzle, and gimbaling is minimized as long as no thrust buildup within the SRB is present. At SRB ignition, pressure buildup within the SRB causes the flexible bearing/nozzle combined relative motion to be forced downward along the SRB X-axis. The nozzle can extend on its bearing approximately one inch when the SRM reaches 100 percent thrust.

As the SRB burn is completed, SRM chamber pressure decay permits the flexible bearing/nozzle to return toward the pre-ignition position. The actuators are commanded to the null position for the separation sequence.

The SRM nozzle in the static state can be deflected to  $\pm 3.5$  degrees, in any direction, before the nozzle bearing is overstressed. At normal SRM operating pressures, the nozzle is capable of being deflected  $\pm 8^\circ$  in any axis. Maximum actual gimballed angle is limited by the TVC actuators to  $\pm 5^\circ$  minimum in the plane of the actuator.

#### 5.5 TVC COMPONENT DESCRIPTIONS.

#### 5.5.1 Fuel Supply Module (FSM).

The FSM is a spherical container used to store liquid hydrazine fuel for the APU. The FSM is pressurized with gaseous nitrogen (GN<sub>2</sub>) to deliver the hydrazine to the APU for startup. Hydrazine is introduced to the APU by electrically commanding the fuel isolation valve (FIV) and the secondary control valve to open. The APU gear driven fuel pump takes over to supply fuel to the APU when the fuel pump pressure exceeds the FSM pressure. The FSM has a volume of 1728.19 cubic inches and provides approximately 25 pounds of hydrazine for APU flight operations. The FSM is shown in Figures 5-7 and 5-8.

#### 5.5.2 Fuel Filter.

The fuel filter is located in the fuel line between the FSM and the FIV. The filter is 5.25 inches long, 1.25 inches in diameter and filters all particles of 25 microns and larger.

#### 5.5.3 Single Mission Fuel Isolation Valve (SMFIV).

The FIV is located in the fuel line between the fuel filter and APU. It serves as a positive fuel cutoff during APU non-operating periods. This valve is opened momentarily during prelaunch BITE test and at T-9 hours for fuel pump bearing soak. It is electrically energized to the open position at T-31 seconds in the launch countdown and remains open until SRB separation. At separation, power dead-facing of the subsystem allows the valve to return to its normally closed position. The FIV is shown in Figures 5-9 and 5-10.

#### 5.5.4 Auxiliary Power Unit (APU).

The APU (Figures 5-11 through 5-14) is the power source for the hydraulic pump. This pump is speed controlled to provide a pressurized hydraulic fluid supply necessary to drive each of the two servoactuators of each system. If one of the hydraulic power supplies fails, a valve in the actuators isolates the failed supply, which prevents any loss of thrust vectoring. The APU consists of a fuel pump, a gas generator valve module (Figure 5-15 and 5-16) consisting of a pulse (primary) speed control valve (normally open) and a shutoff (secondary) speed control valve (normally closed); a gas generator (Figure 5-17 and 5-18); a dual pass reentry turbine; a turbine wheel and balance assembly (Figures 5-19 through 5-22); a fixed-ratio gear box; a lubrication system; and various check, service, and relief valves used to effect control and safety of the APU. The APU is nominally controlled to 72,000 RPMs; at this speed it is capable of delivering 135 horsepower to the gearbox output drive shaft. The fuel pump and the lubrication pump are driven through the gearbox gear train.

#### 5.5.5 Gearbox Pressure Equalization Device (GPED)

The GPED is connected to a valve mounted on the APU gearbox to equalize internal and external APU gearbox pressure during seawater immersion. The pressure balance is maintained during recovery to prevent-salt water from entering the APU gearbox.

#### 5.5.6 Hydraulic Pump.

The hydraulic pump is a variable flow, pressure compensated unit spline driven by the fixed ratio APU gearbox. It consists of a wobble plate with nine pistons displacing a total 4.3 cubic inches per revolution. The pump has a pressure compensator control to regulate the volume of fluid delivered to the TVC system while maintaining a predetermined pressure. The hydraulic pump delivers approximately 55 GPM at 3804 RPM and 3050 PSIG. Overall length of the hydraulic pump is 10 inches, width 6-3/4 inches and height 8-5/8 inches. Refer to Table 5-1 for leading particulars. A solenoid incorporated in the hydraulic pump allows it to compensate at a reduced controlled pressure of 500 to 1000 PSIG for startup. Figure 5-24 shows an outline drawing of the hydraulic-pump. Figure

5-25 shows a sectional view of the hydraulic pump. See Figures 5-23 through 5-28 for pump and component details.

TABLE 5-1. Leading Particulars for APU Driven Hydraulic Pump

Weight	34.0 lbs (dry)
Rated Speed	3804 RPM
Flow (at rated load)	55.0 GPM @ 3050 PSIG
Flow (at maximum load)	66.3 GPM @ 3050 PSIG
Rated Discharge Pressure	3200+-50 PSIG
Rated Inlet Pressure	55 to 75 PSIG
Rated Temperature (at pump inlet)	240+-20F
Rotation (viewing pump drive shaft)	CCW
Hydraulic Fluid	MIL-H-38282

#### 5.5.7 Hydraulic Bootstrap Reservoir.

The bootstrap reservoir stores approximately 2.2 gallons of the total 5.3 gallons of hydraulic fluid in the HPU. The bootstrap reservoir has a spring-loaded piston that compensates for fluid volumetric changes resulting from temperature and system operating conditions. The spring-loaded-piston provides a minimum 3.0 PSIG hydraulic fluid starting pressure at the hydraulic pump inlet. The pump outlet pressure is applied to a differential area of the piston to provide for additional pump input pressure. During operation the hydraulic fluid from the reservoir is supplied to the hydraulic pump inlet at  $60 \pm 5$  PSIG. The reservoir also receives the hydraulic fluid returning from the servoactuators. Figures 5-29 through 5-32 illustrate the reservoir details, components, and operation.

#### 5.5.8 Hydraulic Fluid Manifold.

The hydraulic fluid manifold distributes hydraulic fluid through the TVC subsystem and permits filling, bleeding, and initial pressurization of the subsystem and the bootstrap reservoir. Figures 5-33 through 5-36 show the manifold and various inputs and outputs. During ground operation and checkout, high-pressure (3,000 to 3,250 PSIG) hydraulic fluid is supplied from GSE through the high-pressure input on the service panel. Over-pressurization (3,650 PSIG or greater) in the high-pressure circuit is prevented by a high-pressure relief valve that opens and bleeds the overpressure into the low-pressure circuit of the manifold (Figures 5-38 and 5-39 illustrate these valves). This relief valve reseats at 3,350 PSIG minimum. A low pressure circuit relief valve relieves pressure at 80-125 PSIG back to the GSE. This relief valve reseats at 70 PSIG minimum. During flight, the high-pressure fluid from the hydraulic fluid manifold is used to pressurize the bootstrap reservoir. Low-pressure fluid (55 to 80 PSIG) is routed from the servoactuators through the manifold low-pressure chamber to the low-pressure side of the reservoir.

#### 5.5.9 APU Controller

The APU controller, located in the aft IEA of the SRB, controls the HPU. It monitors the turbine speed through signals received from two MPUs located in proximity to the turbine shaft and controls the fuel flow to the gas generator. The fuel flow to the gas generator is controlled by opening and closing the pulse (primary) control valve to maintain turbine speed at 100 percent or 110 percent. The secondary speed control valve is cycled to maintain 112 percent turbine speed.

#### 5.5.10 Hydraulic Fluid Check Valve and Filter

This check valve and filter is located in the hydraulic line between the hydraulic pump and the servoactuators. The check valve blocks backflow into the hydraulic pump during system bleed and fill, and the filter removes non-soluble pollutants that are larger than 5.0 microns from the hydraulic fluid. The check valve and filter assembly are shown in Figure 5-40 and 5-41.

#### 5.5.11 Hydraulic Pressure Block.

The hydraulic pressure block is located between the servoactuator and the hydraulic accumulator in the high-pressure line. It contains a transducer for measuring pressure in the high-pressure line.

#### 5.5.12 Subsystem Service Panels.

Three service panels for each of the HPUs (Figure 5-5 and 5-42) are accessible through cutouts in the aft skirt and are used for the TVC subsystem ground servicing. These panels contain quick-disconnects (Figure 5-43), manual valves (Figures 5-44 and 5-45), and fittings. Access to these components permits N<sub>2</sub>H<sub>4</sub> fill and drain; GN<sub>2</sub> pressurization and purge; hydraulic fill, bleed, and drain; hydraulic ground checkout with GSE; low-pressure relief valve venting; and post-operation servicing.

#### 5.5.13 Accumulator.

The accumulator consists of a container that houses a chamber of GN<sub>2</sub> charge, a chamber for hydraulic fluid, and a floating separator between the gas and fluid. The separator can be one of two types: the piston type or the bellows type. The piston type separates the gas from the fluid by a floating piston, shown in Figure 5-46. The piston type accumulator requires ground servicing provisions for GN<sub>2</sub> pressurization that is accomplished by the charging block assembly. The charging block is connected to the accumulator by a gas line and is equipped with a transducer for sensing the gas pressure during pressurization. The accumulators are pre-charged at 2,000 ±50 PSIG at 70 ±50F. The hydraulic subsystem fluid pressure is 3,250 PSIG. The piston type accumulator contains a bleed port between the gas and fluid side seals on either end of the piston. This bleed port is capped during flight. The accumulator acts as a suppressor for pressure surges associated with quick acting valves; it also acts as a thermal expansion/contraction compensator by absorbing the hydraulic fluid volume increase when temperature rises and returning fluid to the subsystem when temperature falls.

The bellows type accumulator performs the same functions as the piston type; however, the configuration is slightly different. The bellows type is charged with GN<sub>2</sub> at the factory and the fill line is permanently sealed. The bellows type has a pressure gage on the gas side, and when the accumulator is below acceptable pressure, the accumulator is changed out. The bellows type accumulator (see Figure 5-47) does not use the charging block. Figure 5-48 illustrates the installation of both types of accumulator into the aft skirt structure mid ring.

The APU lube oil accumulator is also a bellows type unit and is shown in Figure 5-49 as installed on the TVC aft ring.

#### 5.5.14 Servoactuators

The two servoactuators, forming a part of the TVC subsystem, are dual action devices (extending and retracting). They convert TVC subsystem hydraulic fluid power to linear motion for positioning the SRM nozzle in response to orbiter attitude commands. The servoactuators are hydraulically interconnected to each TVC HPU for operating redundancy in the event of a failure of either HPU. The servoactuators are connected to the aft skirt attach point and the SRM nozzle by a clevis-pin arrangement. Figure 5-50 shows the servoactuator's typical installation. The servoactuators consist of



four servovalves (Figures 5-51, 5-52, 5-53), a power valve assembly (Figure 5-54), a main actuator piston assembly, four dynamic pressure feedback assemblies (DPFA) (Figure 5-55), four isolation valves (Figure 5-56), four differential pressure transducers (Figure 5-57), a hydraulic lock valve (Figure 5-58), and a mechanical position feedback mechanism (Figure 5-59).

Figure 5-60 shows the functional APU schematic illustrating all of the components, their interaction, and an interface description.

The orbiter attitude commands are transmitted to the servoactuators as four electrical signals proportional to the desired nozzle position. Each signal positions a separate servovalve in the power valve assembly. Each servovalve controls a hydraulic control channel in the power valve assembly. The outputs of the four channels are force-summed at the power valve that controls direction and velocity of the main piston assembly. If the primary supply pressure drops to a specified level (1,900-2,200 PSIG), the pressure-switching valve switches to block the primary system and connect the secondary system from the other fluid power module. If the primary system pressure comes back up (2,300-2,600 PSIG) the spool then switches to again connect the primary system and block the secondary. The end of this valve spool contains an area ported to the primary supply pressure or primary return pressure depending on spool position. Attached to this port is a pressure switch (called the actuator "pressure O.K." switch) that is normally closed when primary pressure is normal. When primary pressure falls, the change in fluid pressure causes this switch to open. This switch is used to affect an increase in speed of the other fluid system's APU. Each servovalve differential pressure is sensed by a differential pressure transducer. This transducer output is monitored by orbiter control circuitry. When a servovalve output pressure exceeds 2,100 PSIG for 120 milliseconds or more, that channel is isolated by the solenoid isolation valve for the duration of flight. A hydraulic lock valve located in the actuator body is a pressure-actuated spool valve located between the power valve and power piston. This valve can be manually opened (fluid bypasses the piston) to allow the piston rod to be moved by hand. With the valve returned to its normal operating position, the valve unlocks the piston when hydraulic pressure exceeds 1,000 PSIG and locks up the piston when fluid pressure drops below 600 PSIG. The piston position feedback mechanism provides servoactuator displacement output to each of four servovalves to close the servoactuator position control loop. The servoactuators extend or retract  $6.40 \pm 0.03$  inches from the midstroke position at a piston rod velocity of approximately 6.0 inches per second under a rated load of 63,348 pounds. Figures 5-61 through 5-63 show the servoactuators. At maximum servoactuator command under rated load, the minimum gimbal acceleration rate is two radians per second squared. Figure 5-64 shows the TVC actuator polarity. Figure 5-65 is an additional view of the TVC operation. Figures 5-66 and 5-67 shows the SRB APU Controls and Measurements (for Rock A). Figure 5-69 depicts the Hydrazine Control Subsystem.

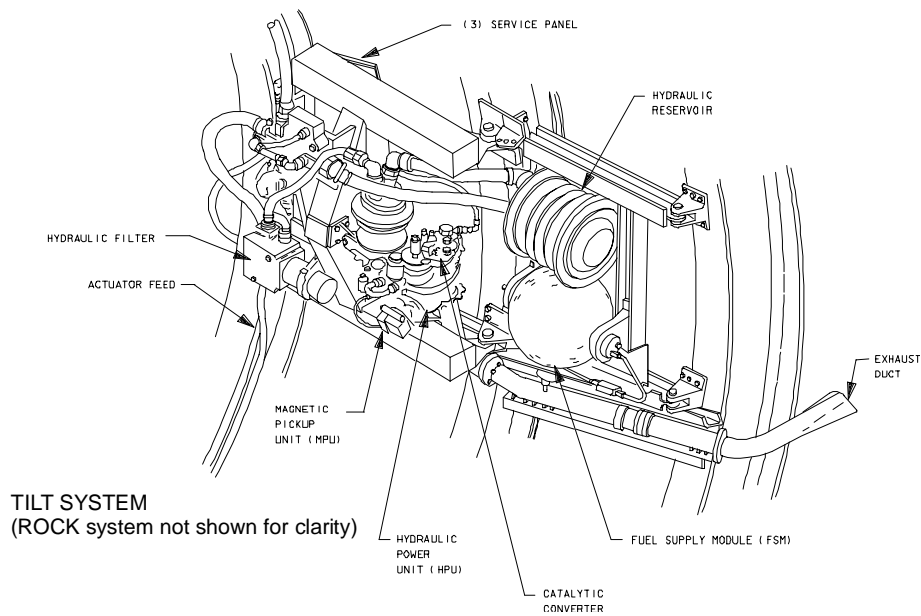

Figure 5-1. SRB Tilt Thrust Vector Control Subsystem in Aft Skirt

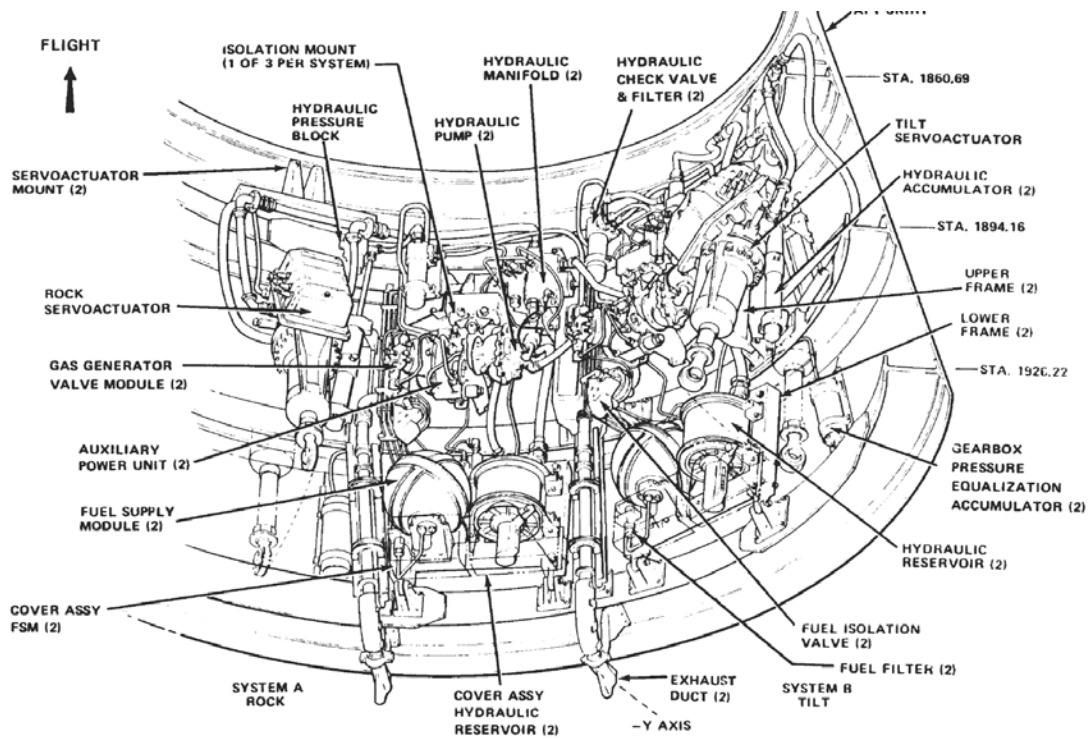

Figure 5-2. SRB Thrust Vector Control Subsystem in Aft Skirt

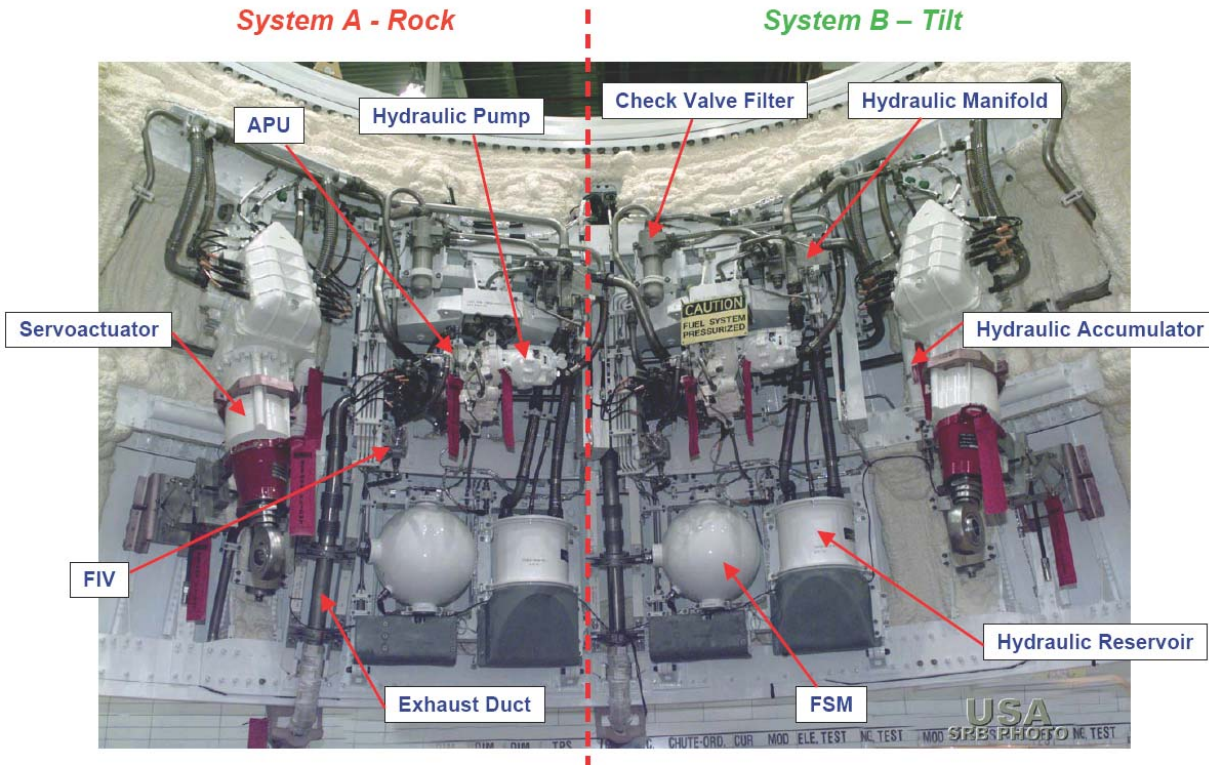

Figure 5-3. SRB As Installed in Aft Skirt

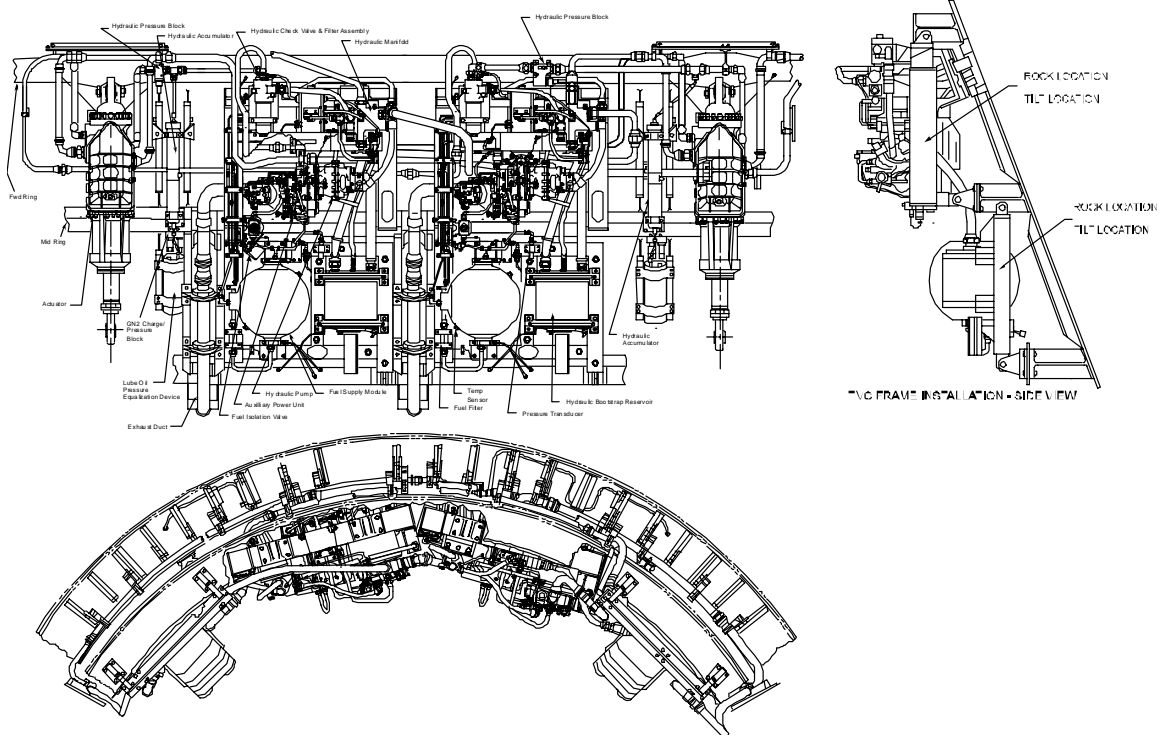

Figure 5-4. TVC Schematic Views



Figure 5-5. TVC Access Ports in Aft Skirt

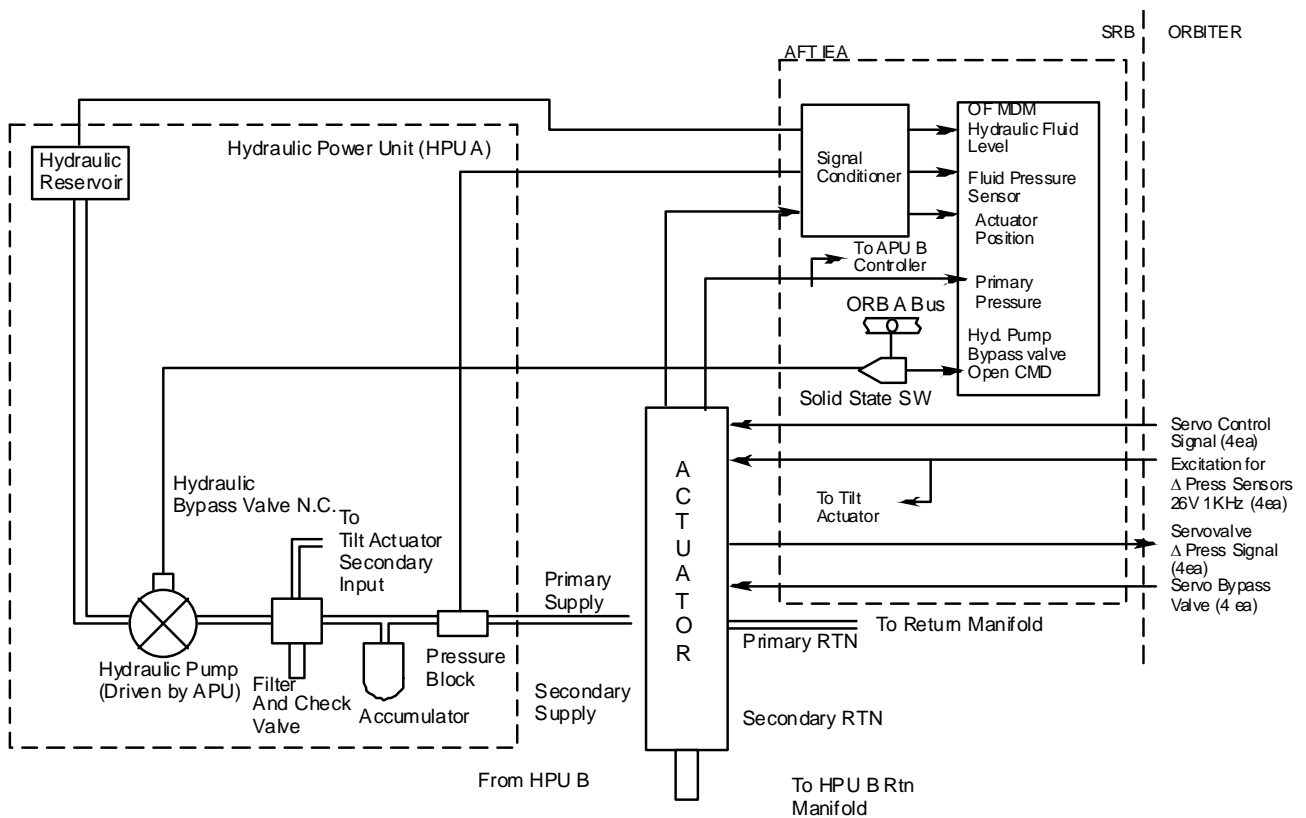

Figure 5-6. HPU A/Rock Actuator Hydraulic Control Subsystem

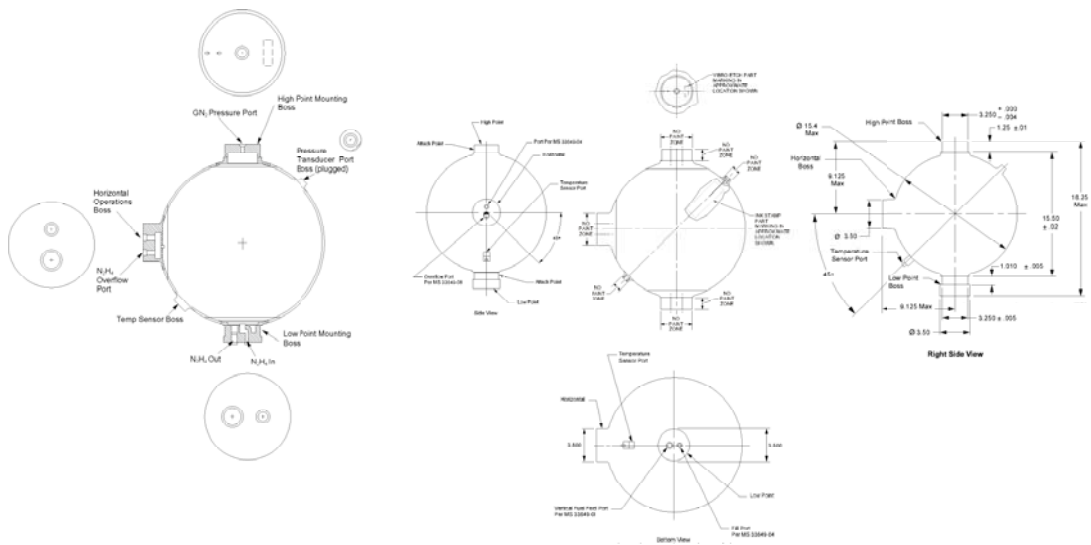

Figure 5-7. Fuel Supply Module Schematic views

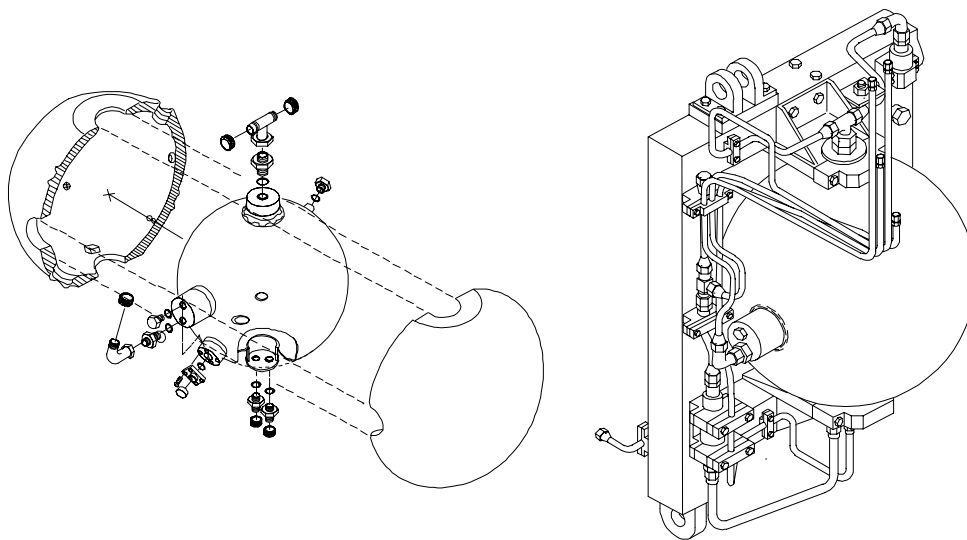

Figure 5-8. Fuel Supply Module Components and Installed in TVC Framework

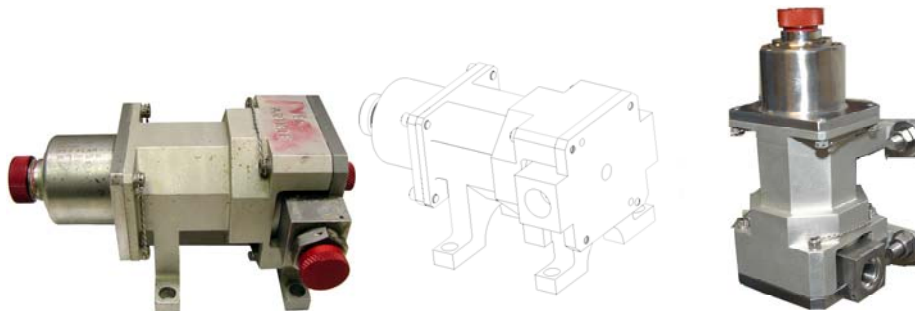

Figure 5-9. Fuel Isolation Valve Isometric Views

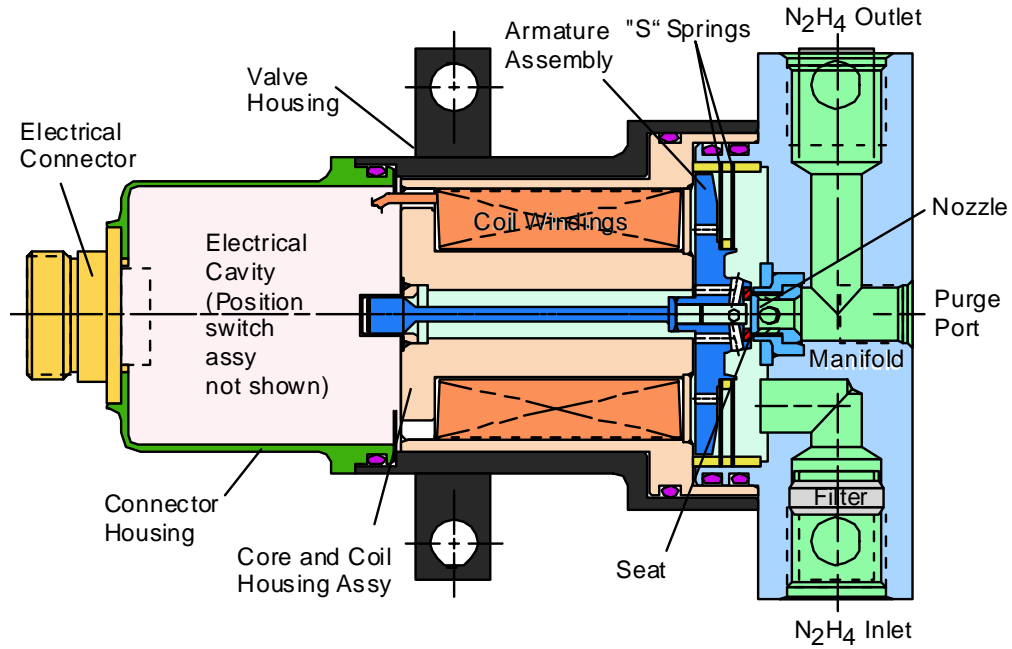

Figure 5-10. Fuel Isolation Valve Cutaway

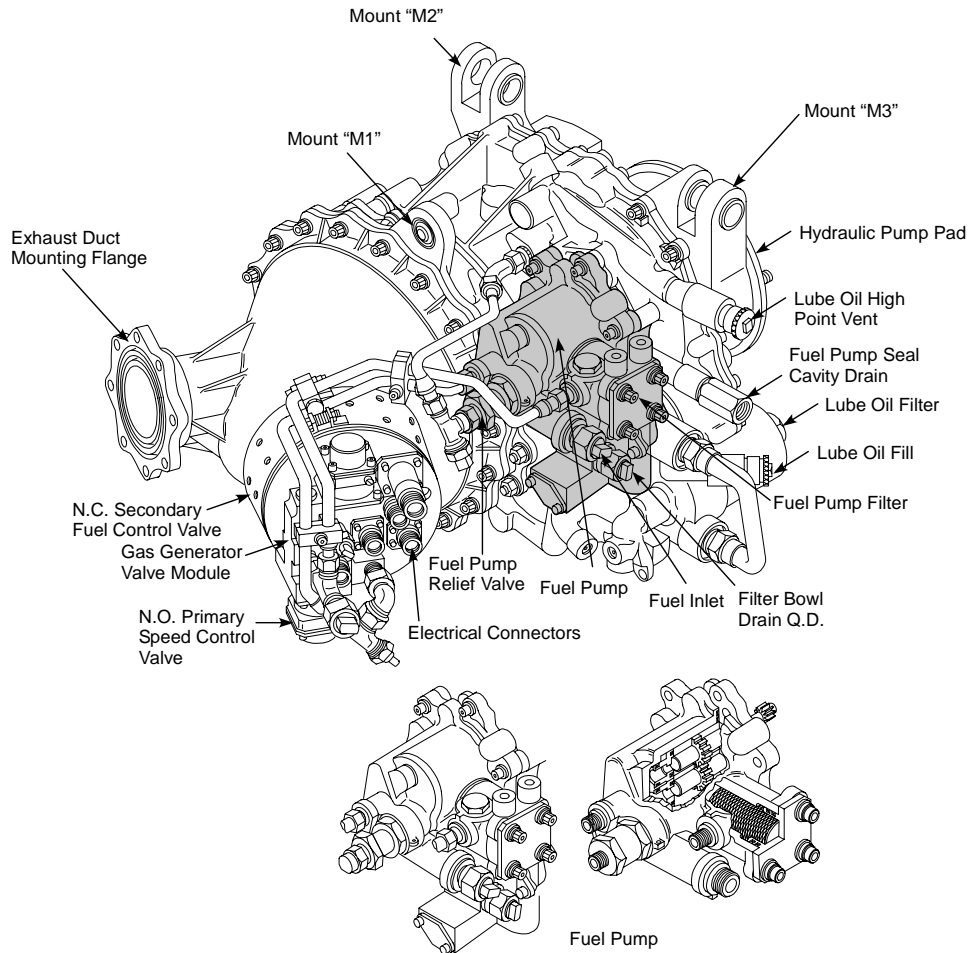

Figure 5-11 Auxiliary Power Unit Detail Orthogonal View 1

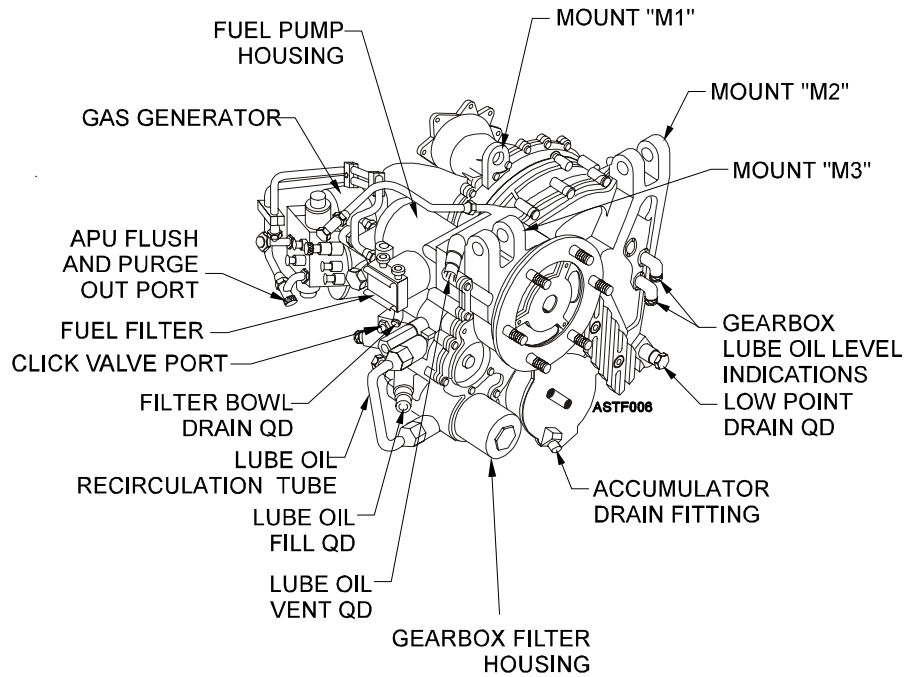

Figure 5-12. Auxiliary Power Unit Detail Orthogonal View 2

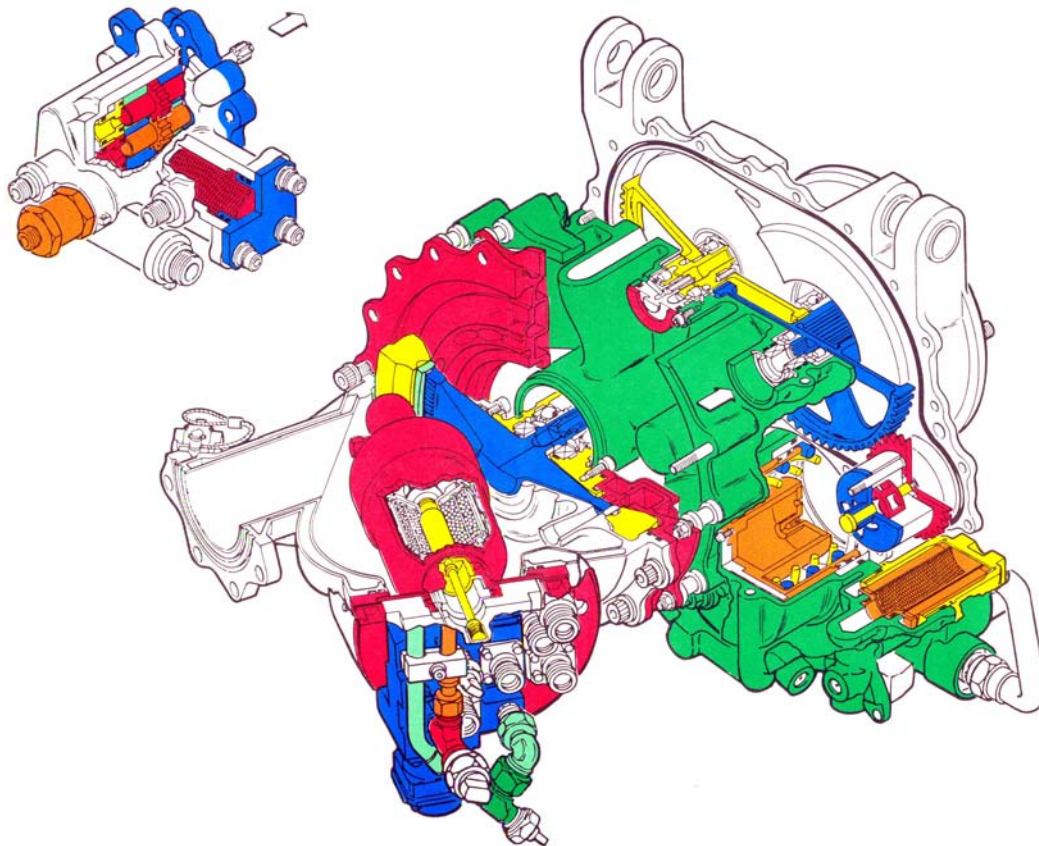

Figure 5-13. Auxiliary Power Unit Cutaway Views

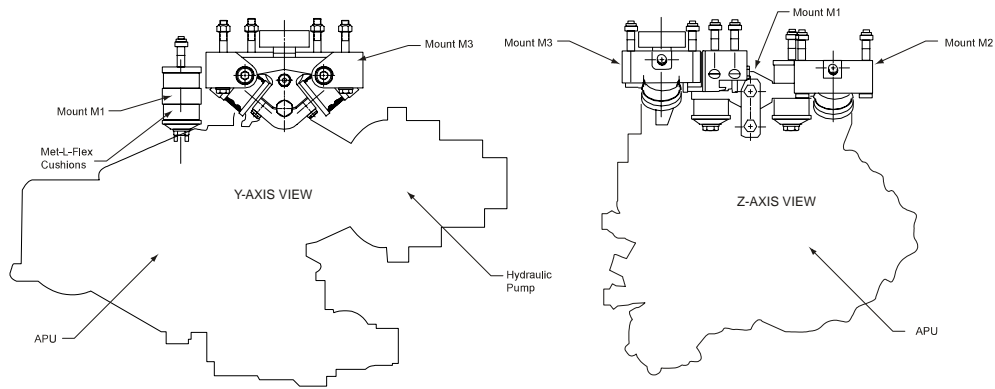

Figure 5-14. APU :Mounting Axes and Mounts

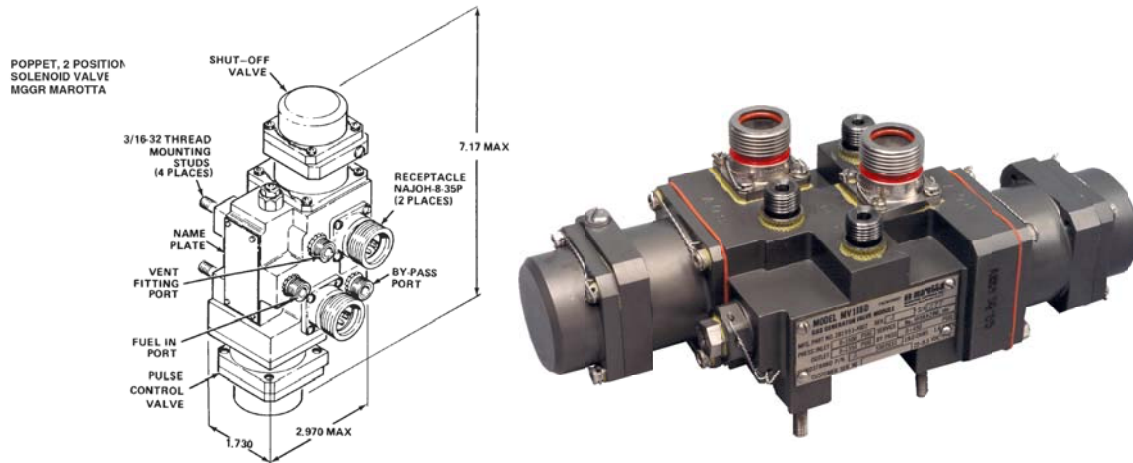

Figure 5-15. Gas Generator Valve Module

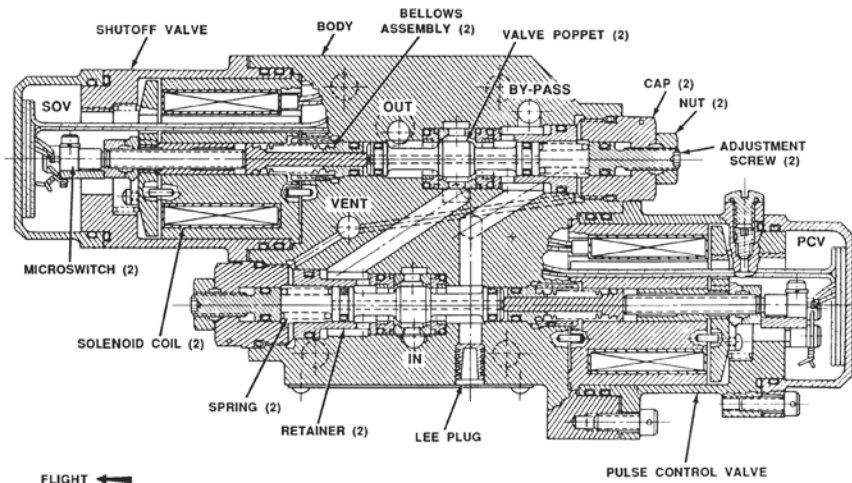

Figure 5-16. Gas Generator Valve Module Cutaway



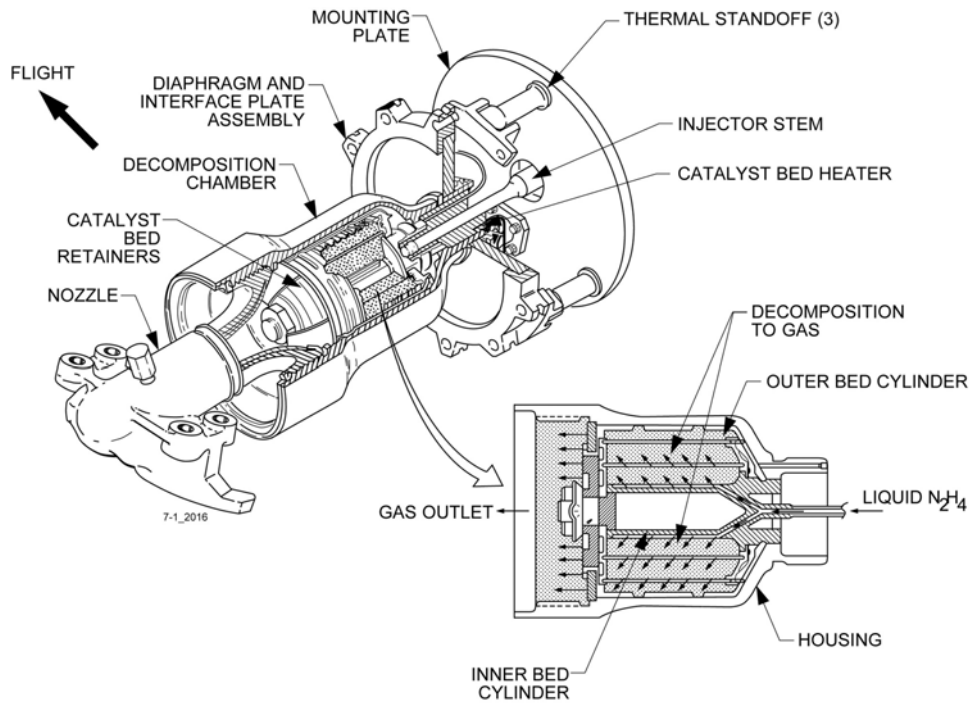

Figure 5-17. APU Gas Generator View 1

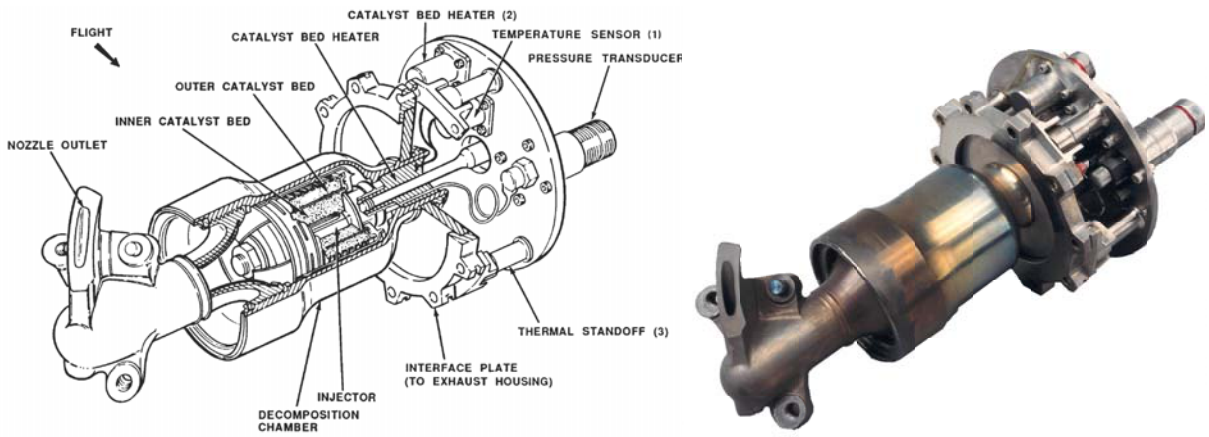

Figure 5-18. APU Gas Generator View 2

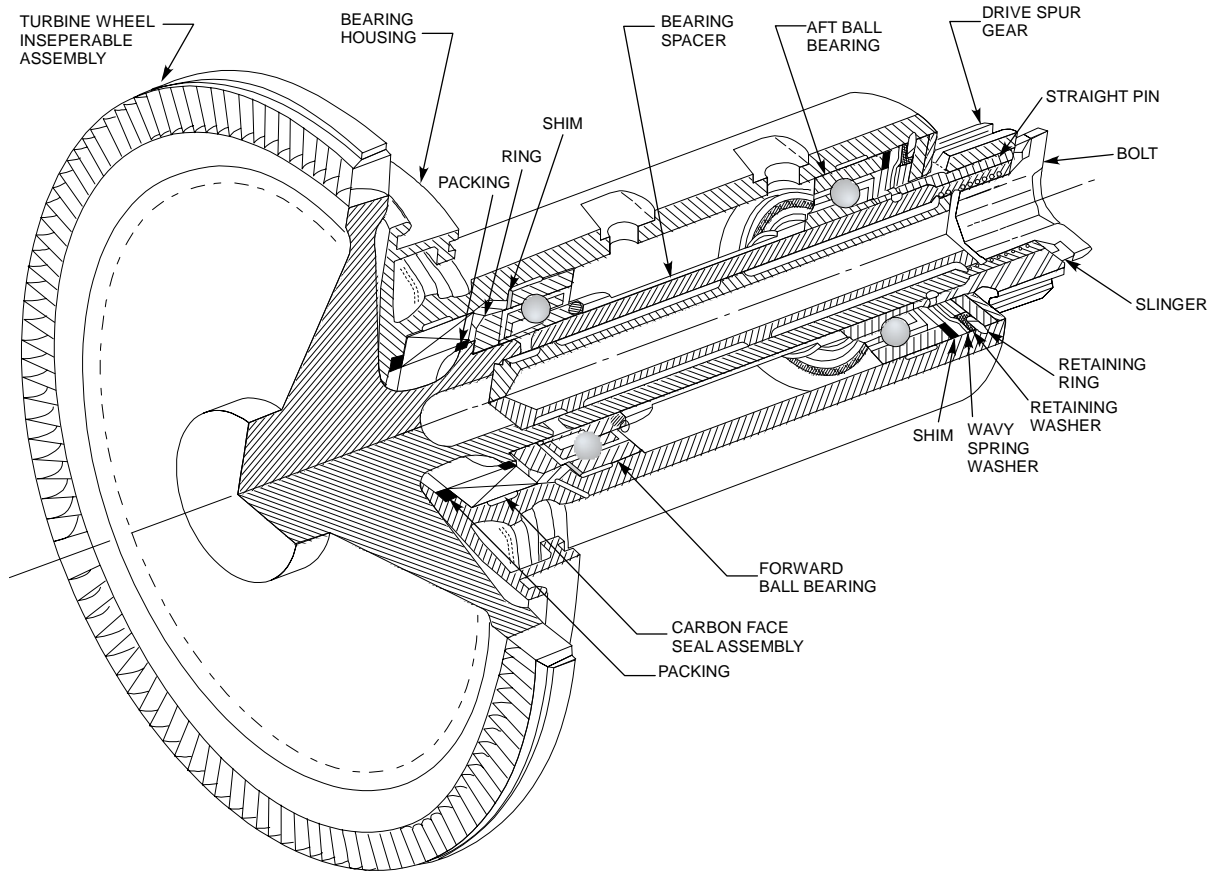

Figure 5-19. APU Turbine Wheel & Balance Assembly

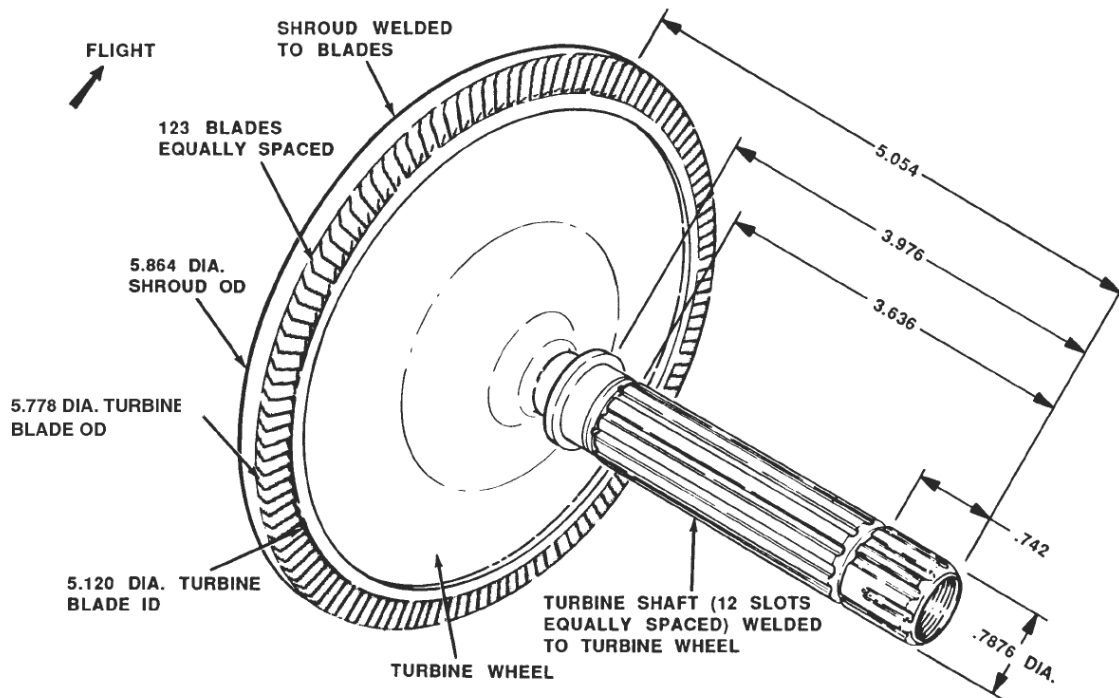

Figure 5-20. APU Turbine Wheel and Shaft

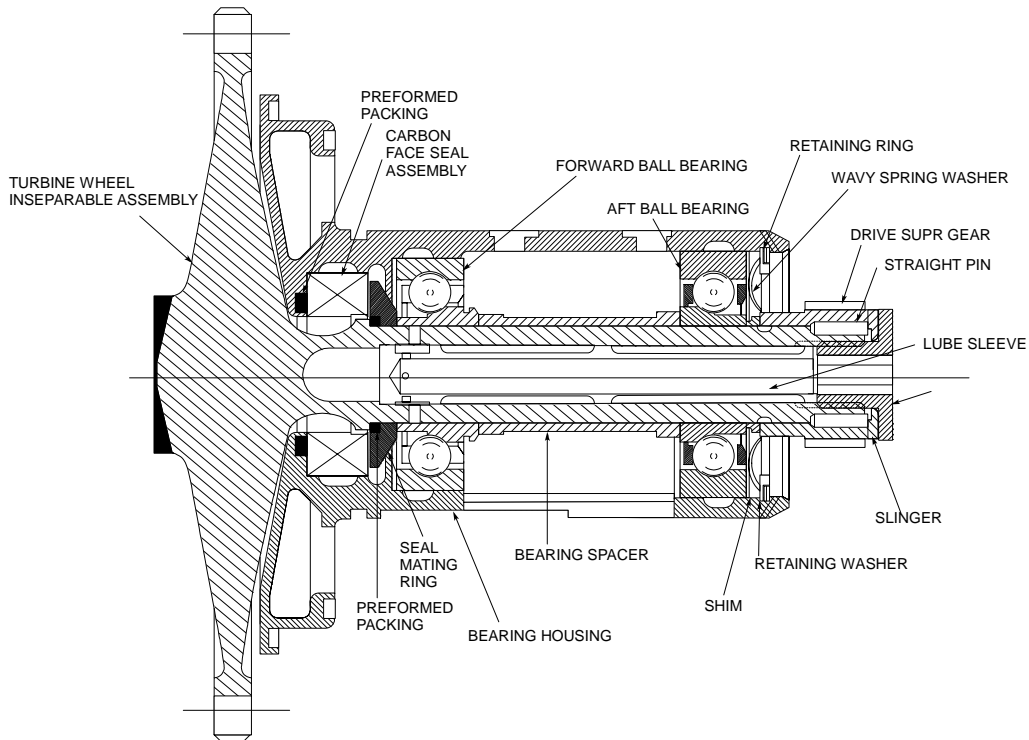

Figure 5-21. APU Turbine Wheel & Balance Assembly Cutaway

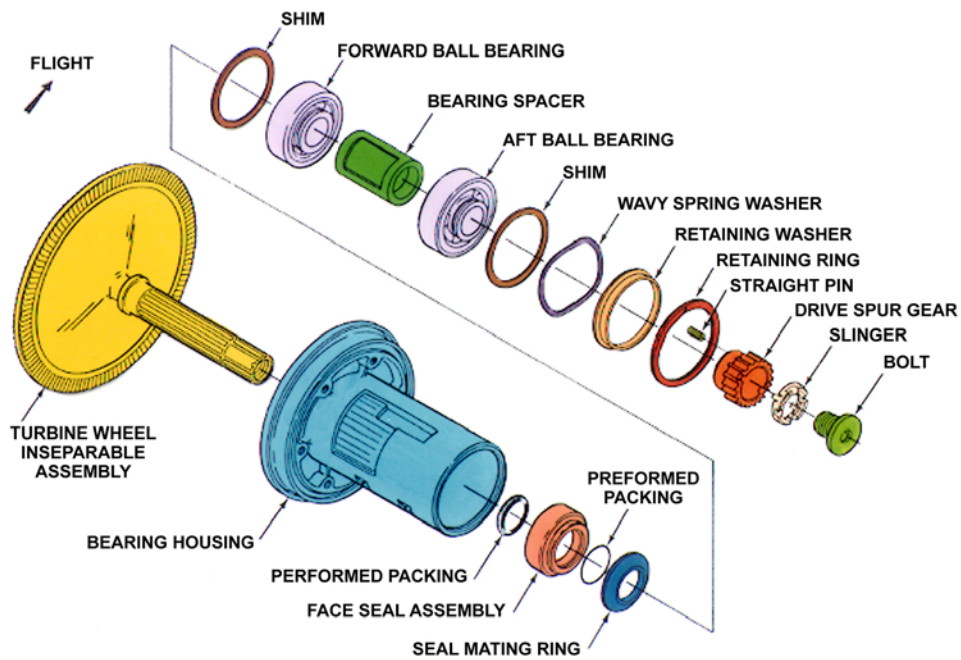

Figure 5-22. APU Turbine Wheel & Balance Assembly Expanded View

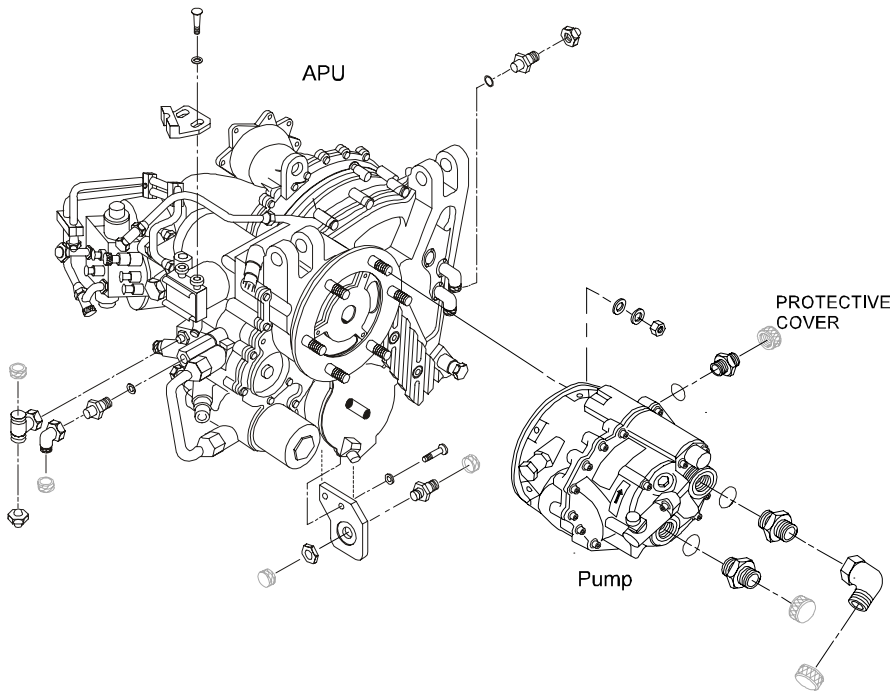

Figure 5-23. APU and Hydraulic Pump Assembly

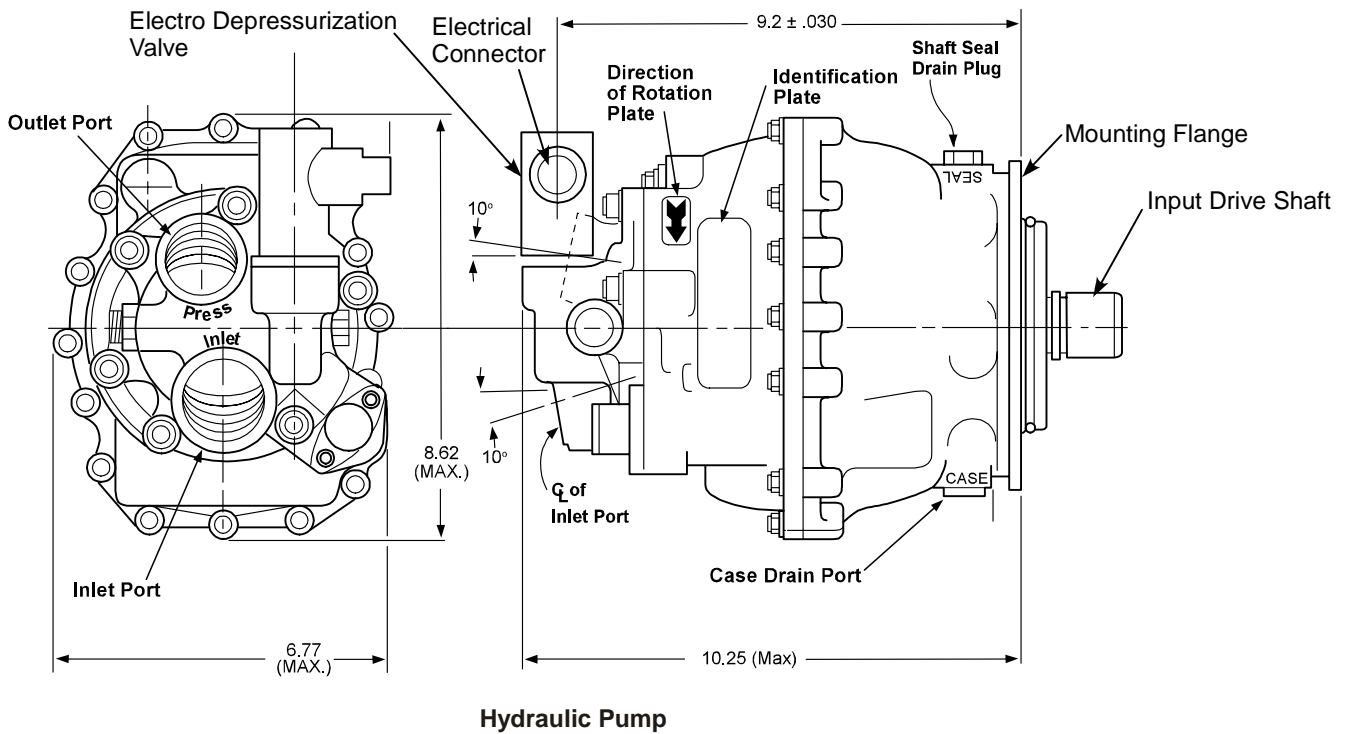

Figure 5-24. TVC Hydraulic Pump Envelope

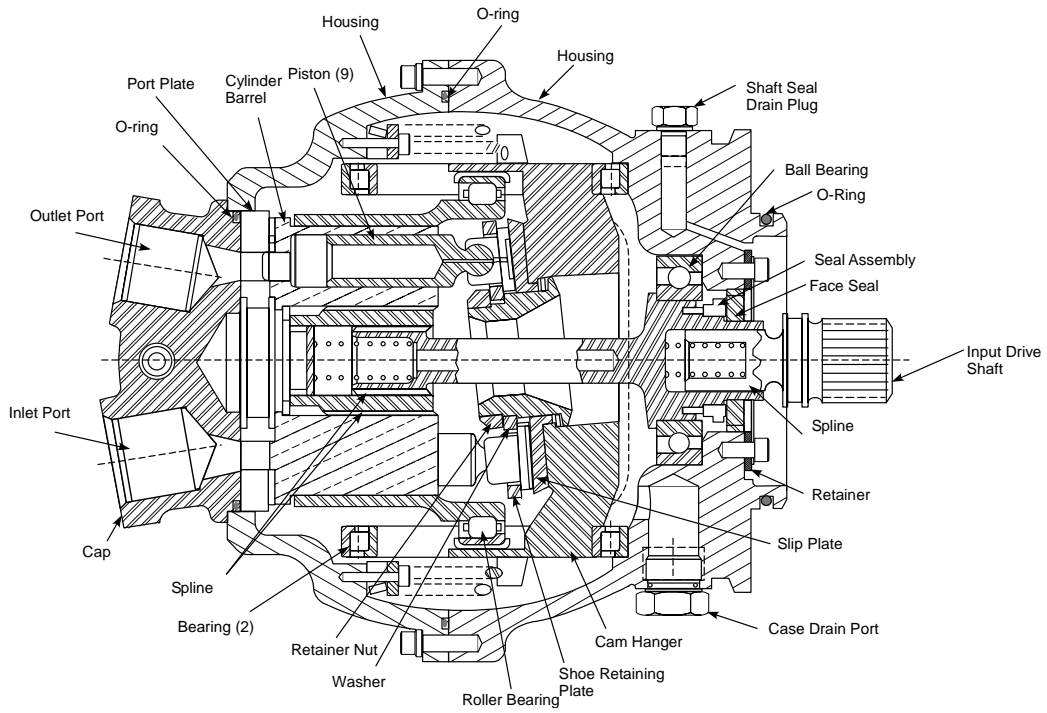

Figure 5-25. Hydraulic Pump Sectional View

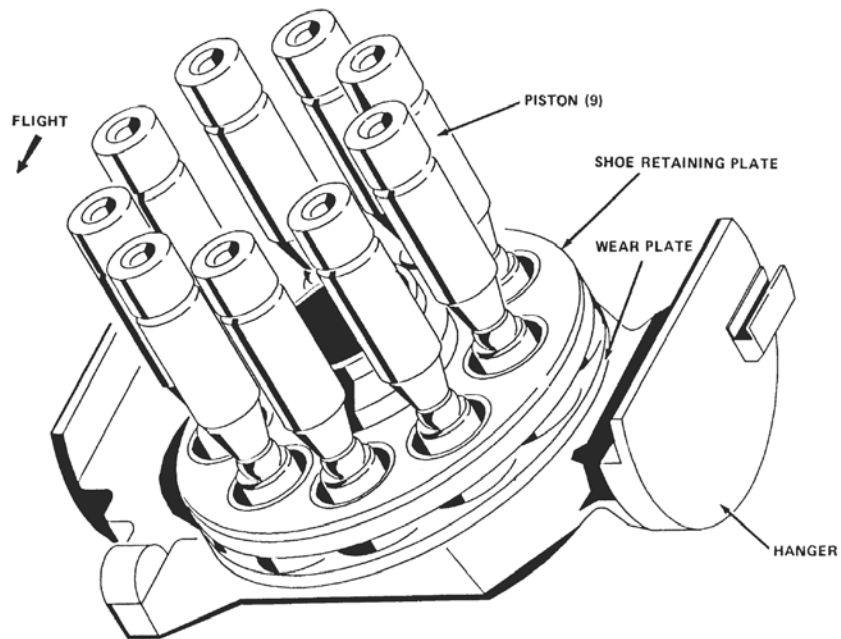

Figure 5-26. TVC Hydraulic Pump Piston Barrel Assembly

Table I Operational Requirements

Condition	Discharge Pressure (psig)	Flow (GPM)	Inlet Fluid Temperature (F)	Inlet Pressure (psig)	RPM
I	3200 ± 50 (Rated)	0	+20 to +240	55 to 100	3614 to 4375 (3804 Rated)
II	3050 ± 50 (Full flow)	55 (Rated)	+35 to +240 (Rated)	55 to 80 (Rated)	3804 (Rated)
III	500 to 1000	5 max.	+35 to +240	5 to 60	1570 to 3994
IV	3050 ± 50	70	+35 to +240	55 to 80	4200 to 4375

NOTES: These values are based on a theoretical pump displacement of 4.3 Cubic inches per revolution and compressed flow conditions.

The discharge pressure requirements between zero and rated flow shall be maintained with an inlet pressure of 55 psig.

The hysteresis pressure-flow characteristics shall be included within the rated flow and zero flow pressure range.

E1237-6a

Table II Port Pressure

Condition	Case Drain Pressure (psig-max)	Inlet Pressure (psig-max)	Discharge Pressure (psig)	rpm	Discharge Flow (gpm)
Proof	300	220	125 percent rated	4,755	0 to 125 percent of rated
Plugged	195	110	rated to full flow	3,804	0 to rated
Clean Filter	125	55	rated fo full flow	3,804	0 to rated

E1237-7a

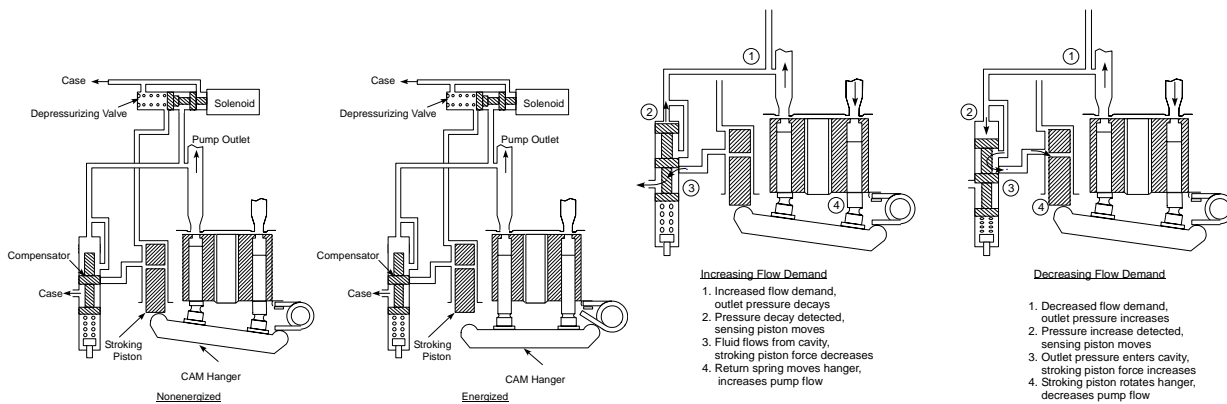

Figure 5-27. Hydraulic Pump Depressurizing System & Pump Compensator Operation

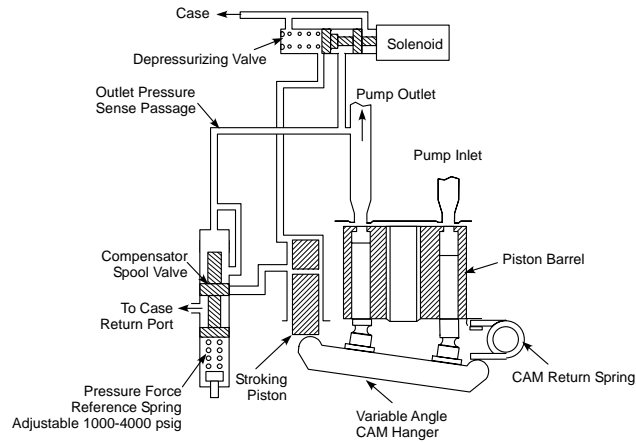

Figure 5-28. Hydraulic Pump Compensating Mechanism

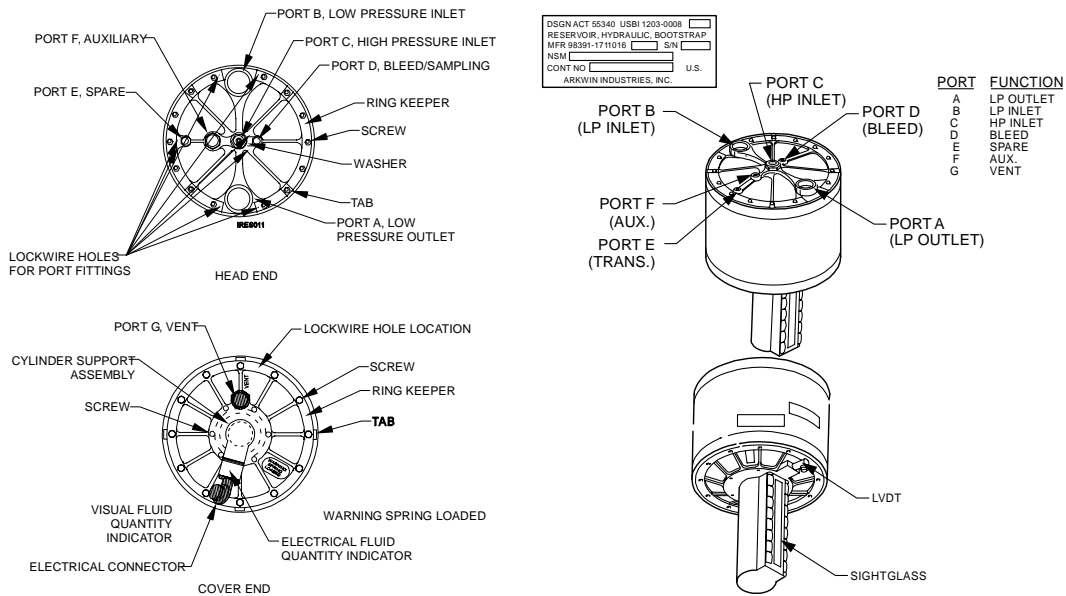

Figure 5-29. TVC Hydraulic Bootstrap Reservoir

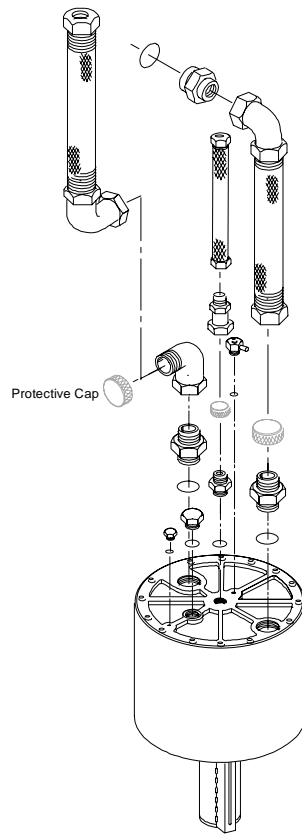

Figure 5-30 Hydraulic Bootstrap Reservoir Connection Hardware

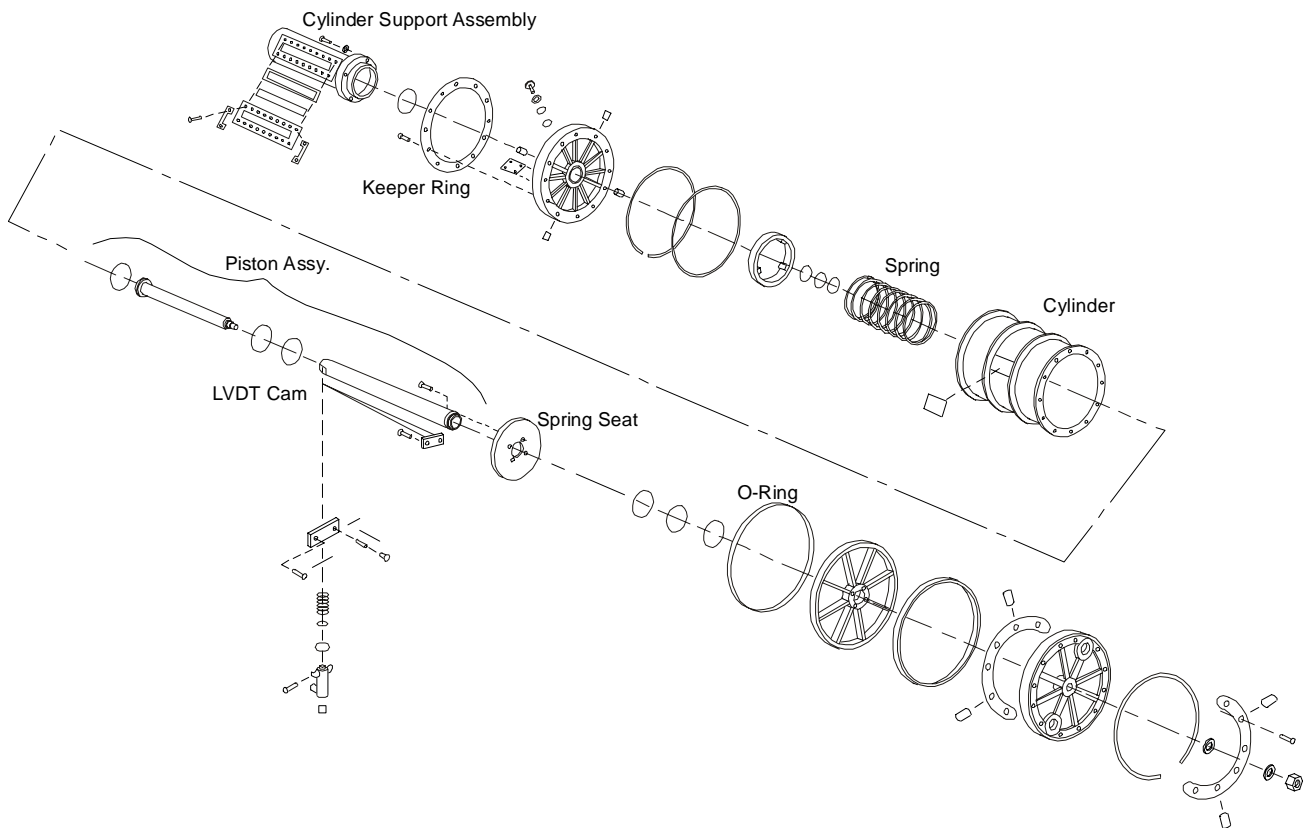
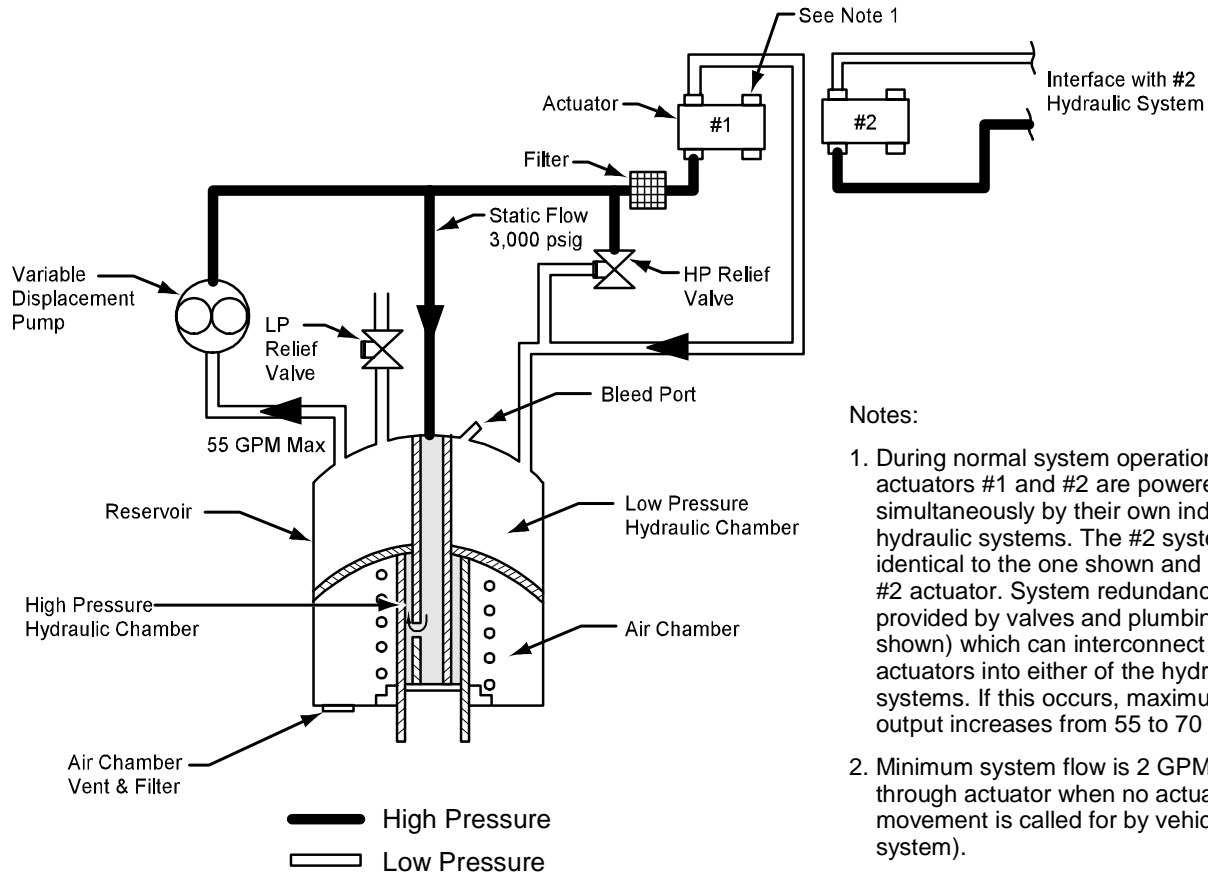

Figure 5-31. TVC Bootstrap Reservoir Expanded View





Notes:

1. During normal system operation, actuators #1 and #2 are powered simultaneously by their own independent hydraulic systems. The #2 system is identical to the one shown and powers #2 actuator. System redundancy is provided by valves and plumbing (not shown) which can interconnect both actuators into either of the hydraulic systems. If this occurs, maximum pump output increases from 55 to 70 GPM.
2. Minimum system flow is 2 GPM (leakage through actuator when no actuator movement is called for by vehicle control system).
3. Actuator stroke and direction are controlled by servo valves (not shown).

Figure 5-32. TVC Bootstrap Reservoir Operational Schematic

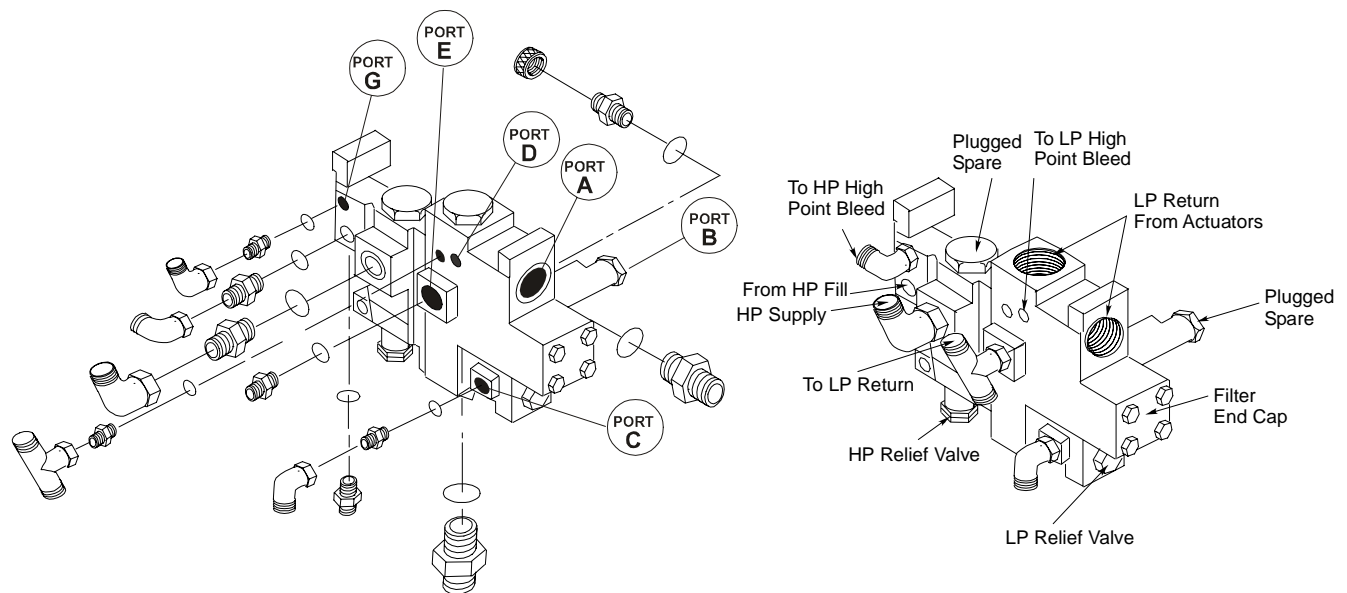

Figure 5-33. TVC Hydraulic Fluid Manifold

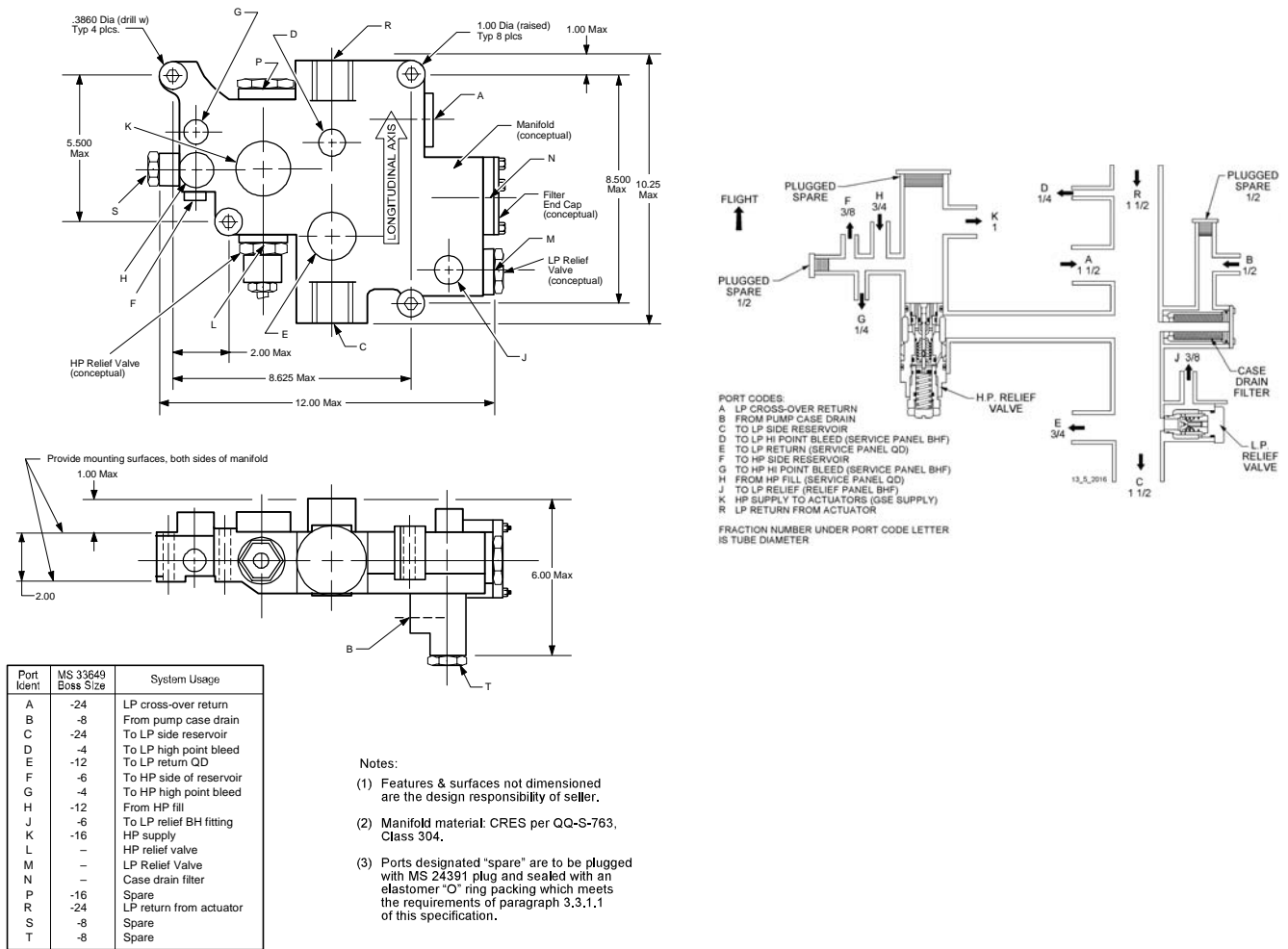

Figure 5-34. TVC Hydraulic Fluid Manifold Schematic and Envelope

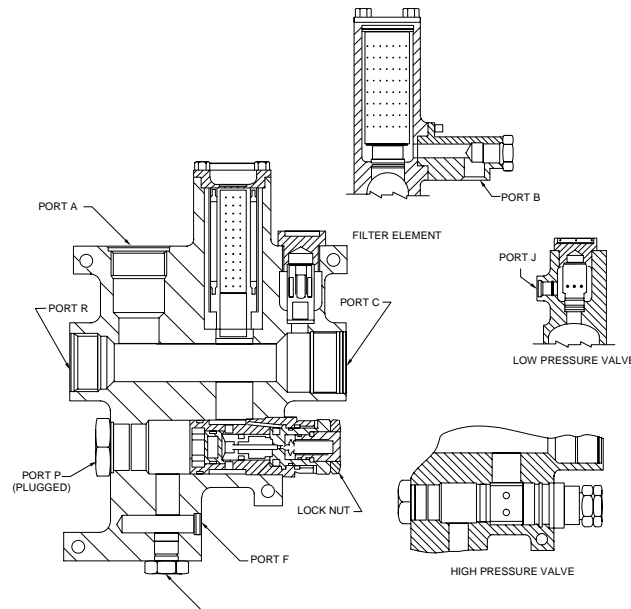

Figure 5-35. TVC Hydraulic Fluid Manifold Sectional Views

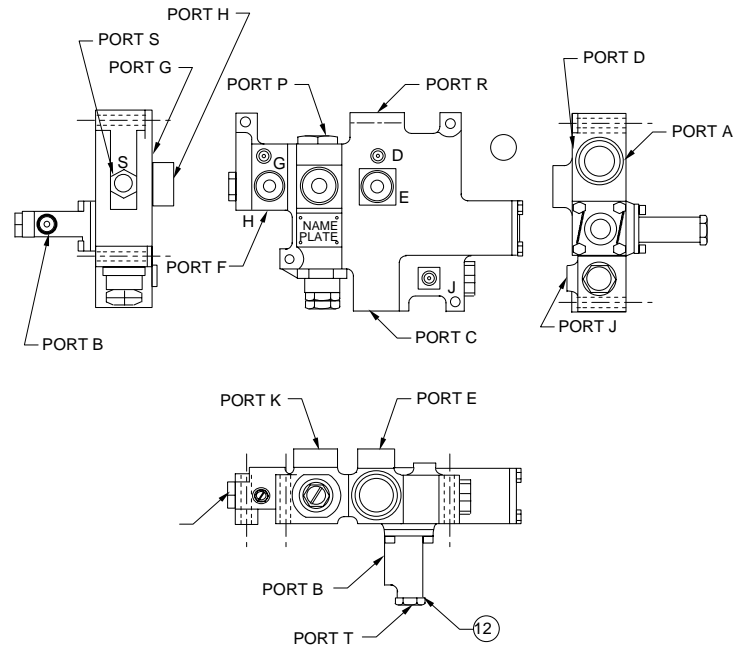

Figure 5-36. TVC Hydraulic Fluid Manifold Port Description

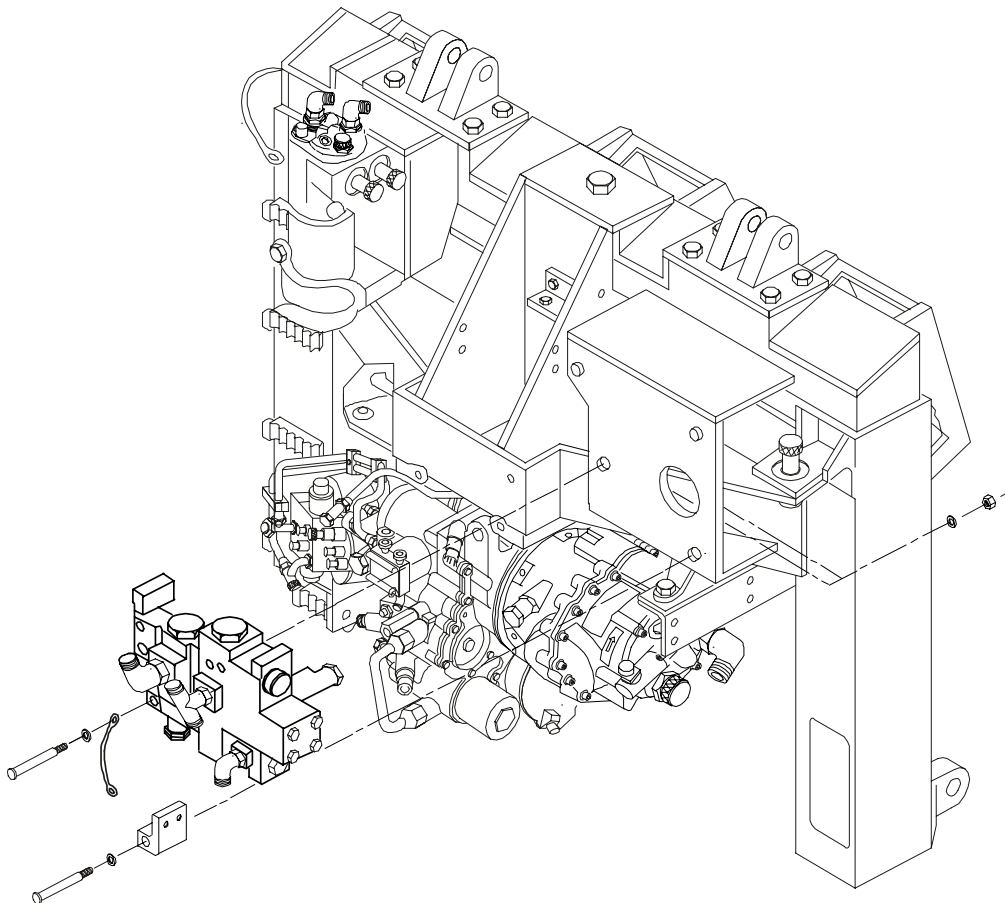

Figure 5-37. TVC Hydraulic Fluid Manifold Installation

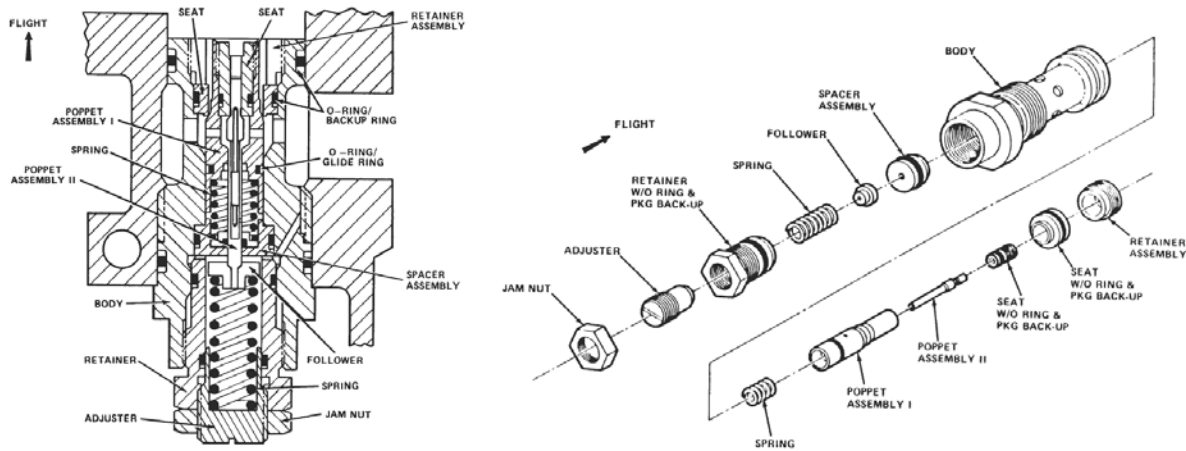

Figure 5-38. High Pressure Relief Valve

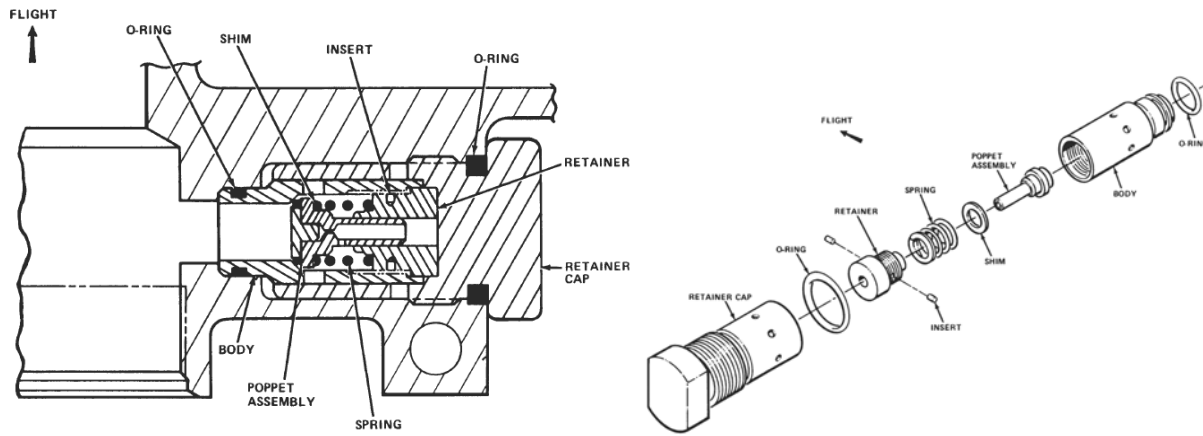

Figure 5-39. Low Pressure Relief Valve

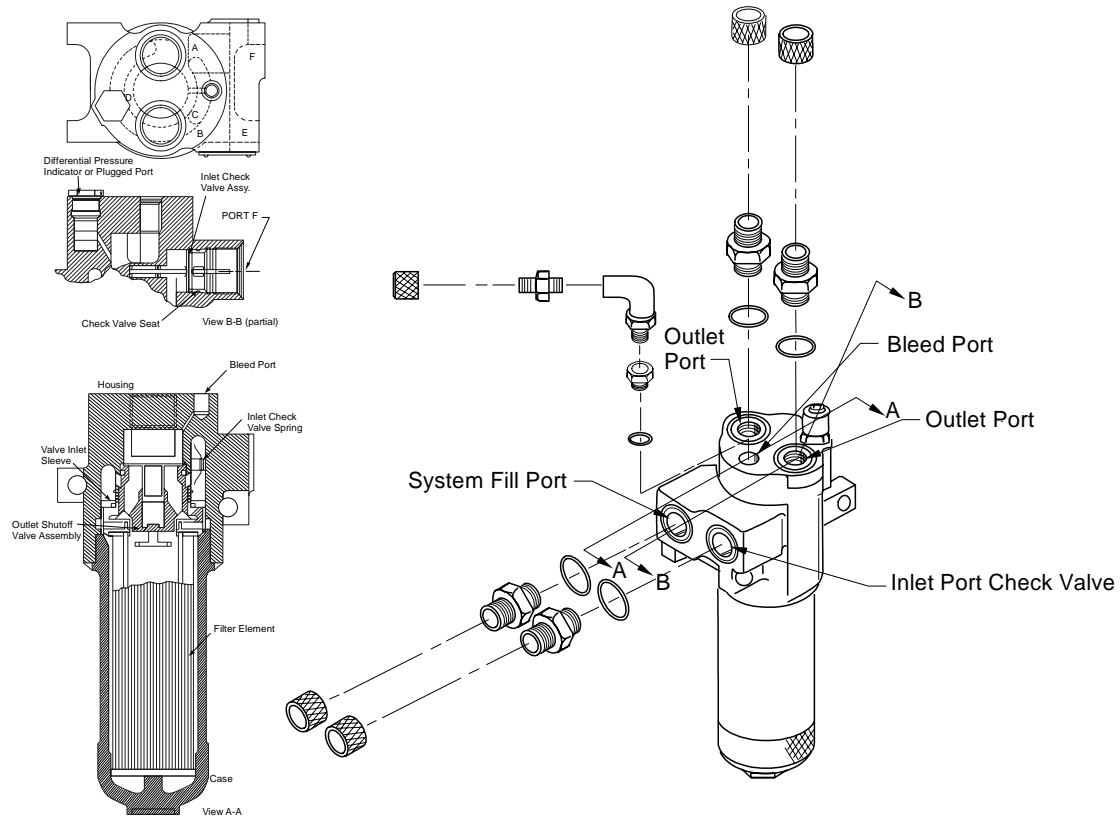

Figure 5-40. TVC Hydraulic Check Valve and Filter Assembly (CVFA)

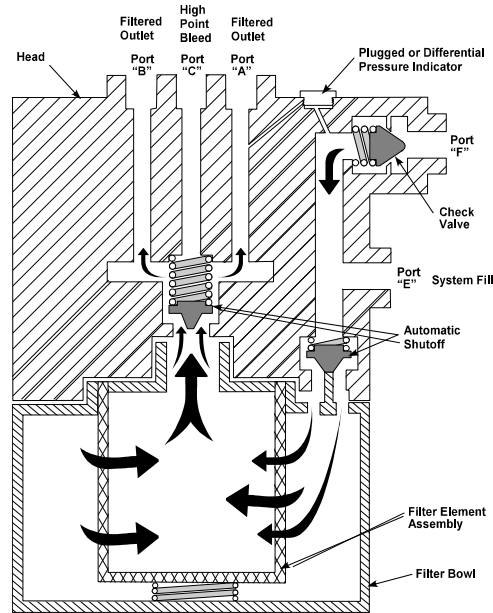

Figure 5-41. Hydraulic CVFA Schematic

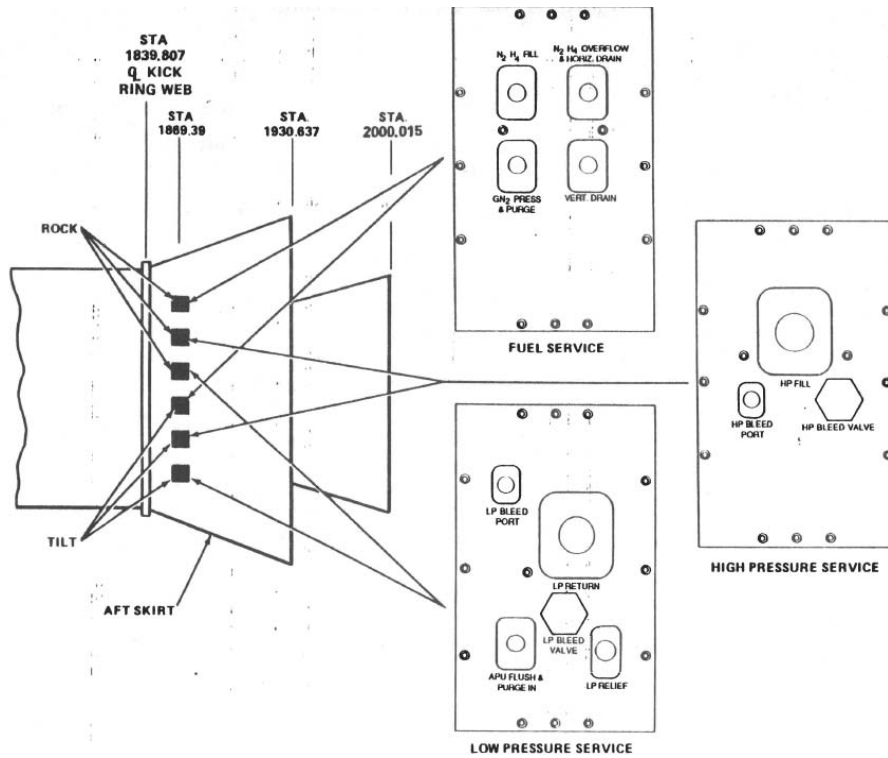
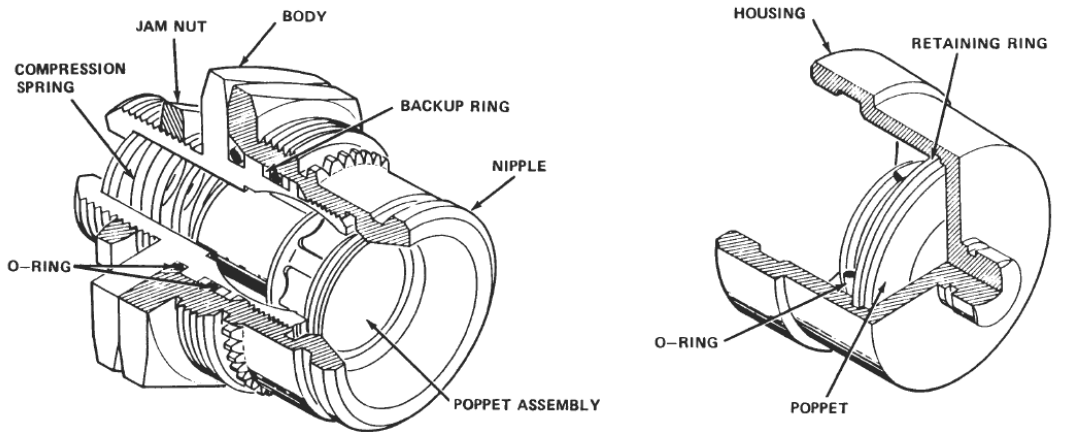

Figure 5-42. TVC Service Panels and Location



AIRBORNE NIPPLE ASSEMBLY  
0.75 INCH SHOWN, 0.25 INCH SIMILIAR  
10201-0055; 0.75 INCH  
10201-0053; 0.25

AIRBORNE CAP ASSEMBLY  
0.75 INCH SHOWN, 0.25 INCH SIMILIAR  
10201-0056; 0.75 INCH  
10201-0054; 0.25 INCH

Figure 5-43. SRB TVC Quick Disconnect

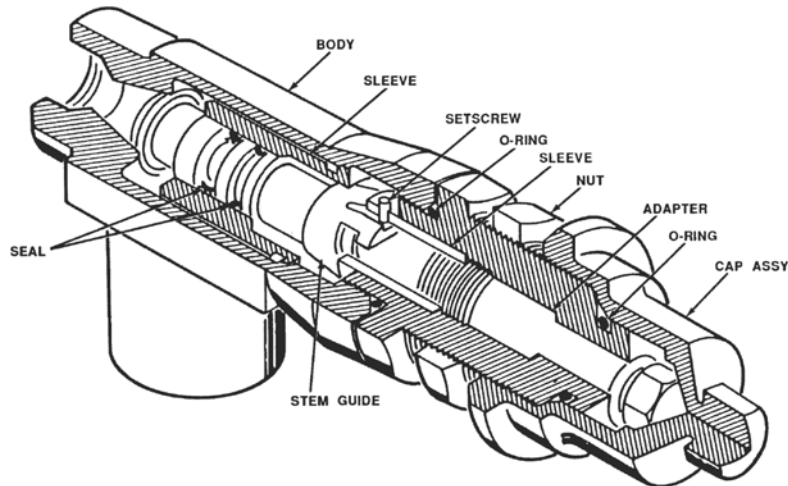

Figure 5-44. SRB TVC Manual Shutoff Valve Assembly

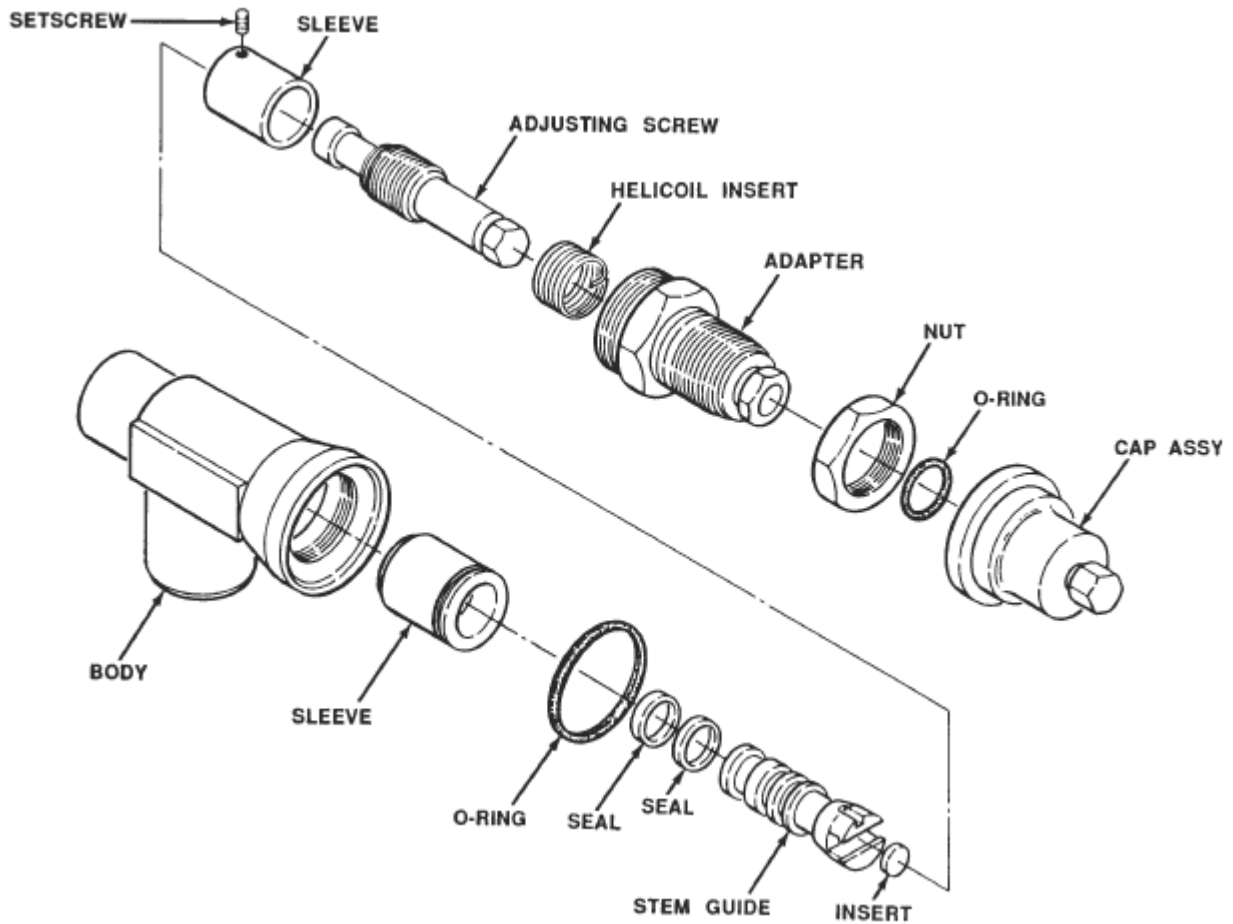

Figure 5-45. SRB TVC Manual Shutoff Valve Assembly (Expanded View)

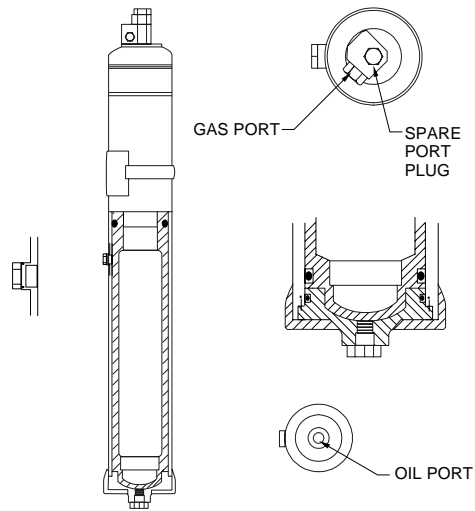

Figure 5-46. TVC Hydraulic Accumulator-Piston Type

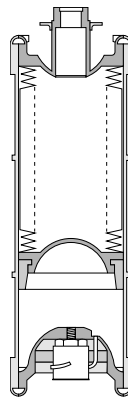

Figure 5-47. TVC Hydraulic Accumulator-Bellows Type



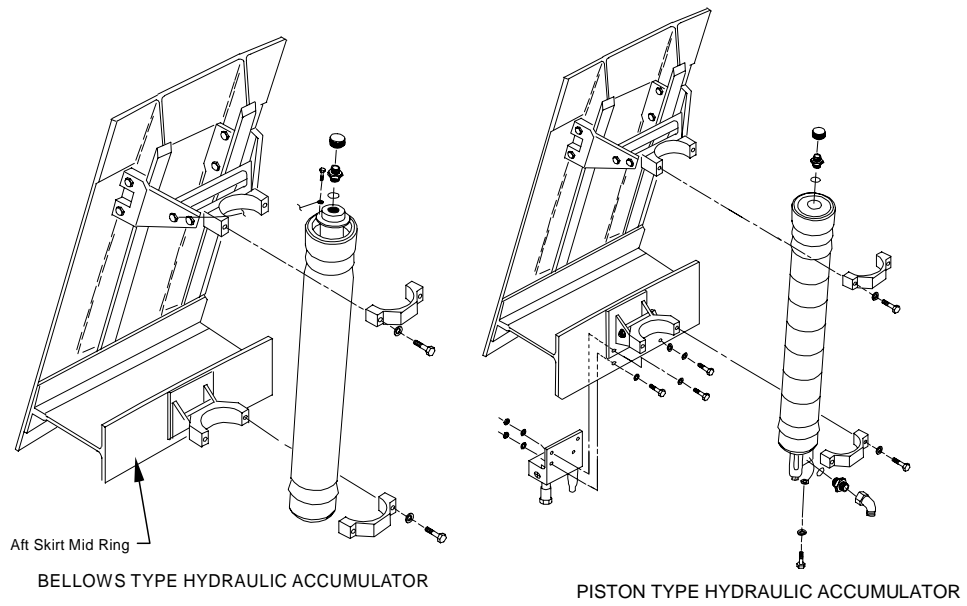

Figure 5-48. TVC Hydraulic Accumulator-Types Installation

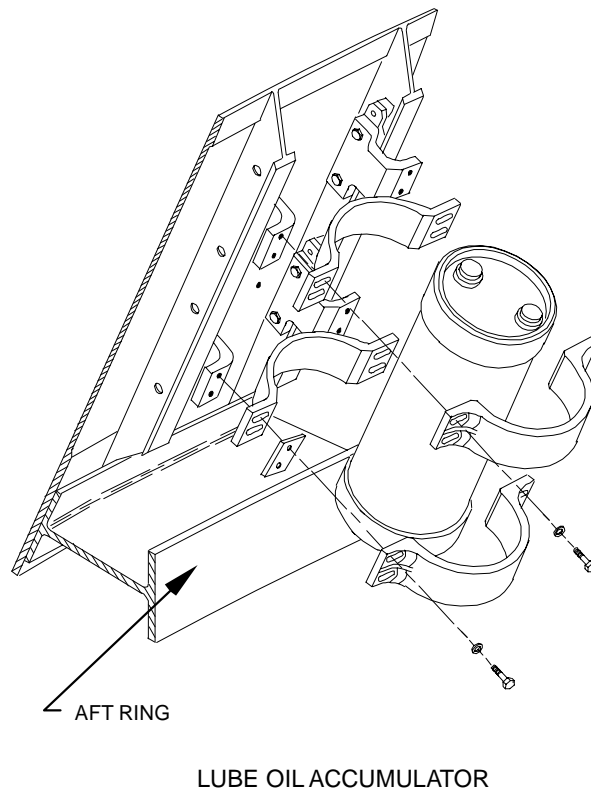

Figure 5-49. SRB TVC Lube Oil Accumulator (Bellows Type)

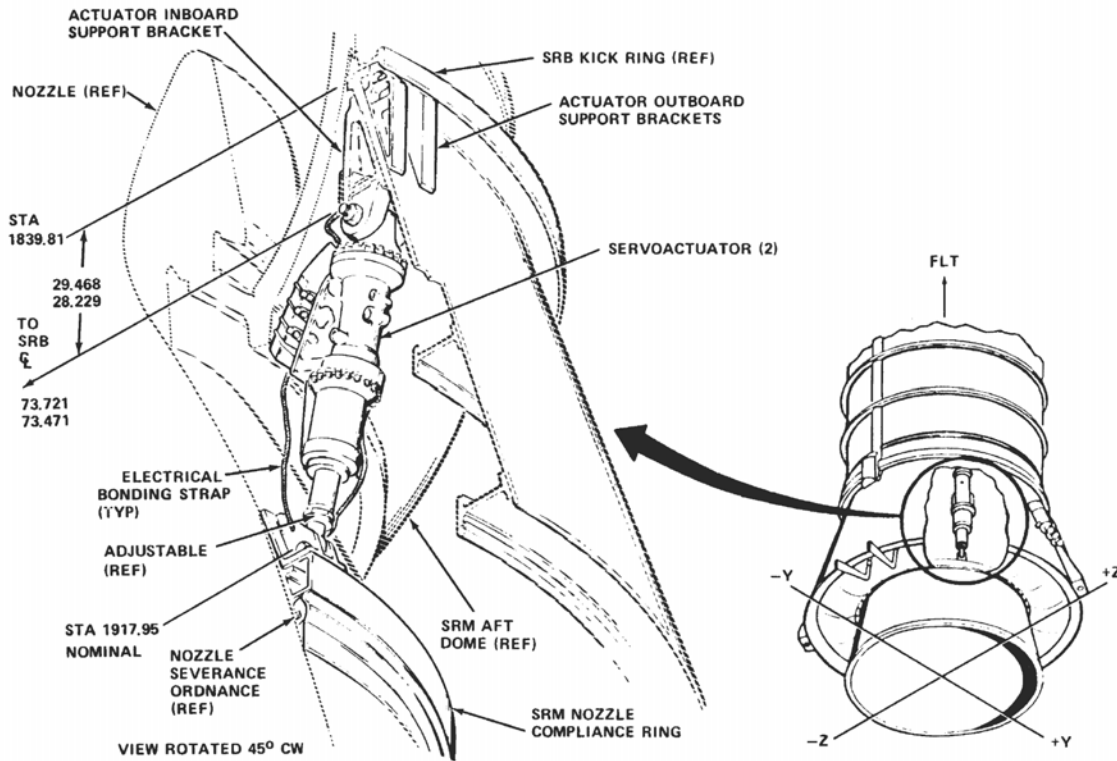

Figure 5-50. TVC Servoactuator Location

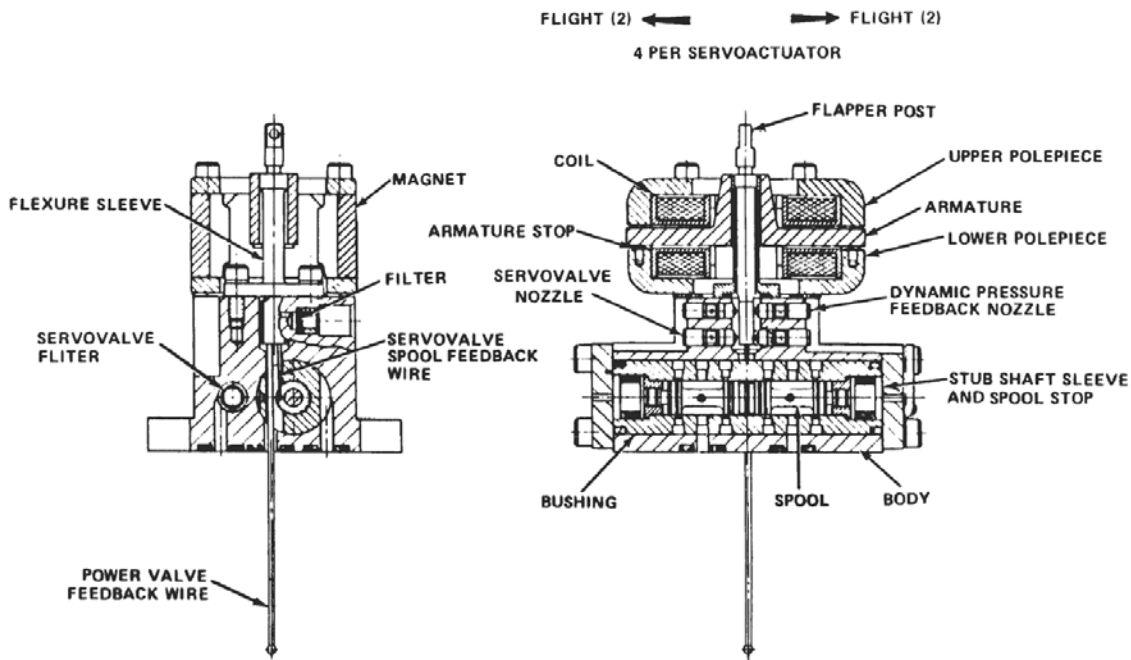
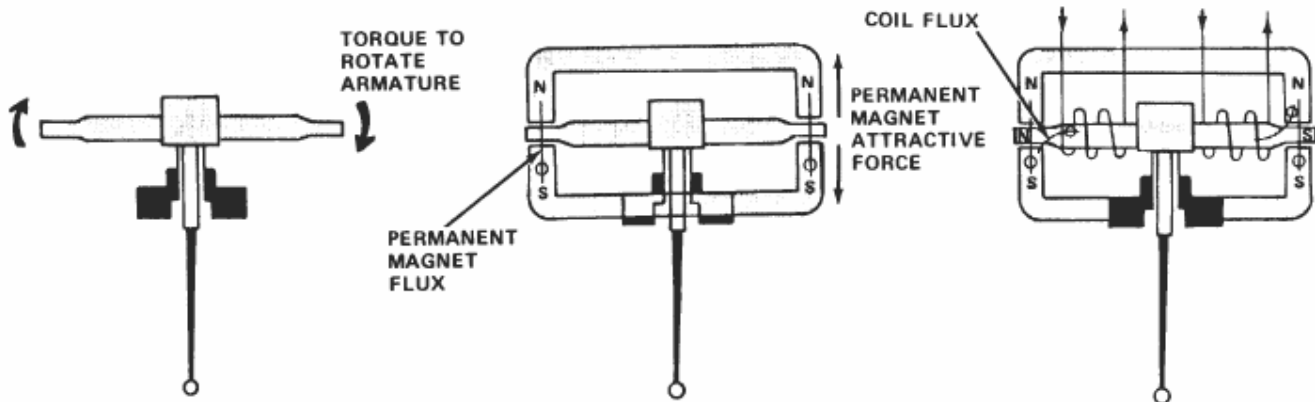

Figure 5-51. Section View of Servovalve Assembly

- PERMANENT MAGNETS CHARGED TO POLARIZE POLEPIECES
- DC CURRENT IN COILS CAUSES INCREASED FORCE IN DIAGONALLY OPPOSITE AIR GAPS
- MAGNETIC CHARGE LEVEL SETS MAGNETUDE OF DECENTERING FORCE GRADIENT ON ARMATURE



- ARMATURE AND FLAPPER RIGIDLY JOINED AND SUPPORTED BY THIN-WALL FLEXURE TUBE
- ROCKING MOTION OF ARMATURE/ FLAPPER THROTTLES FLOW THROUGH ONE NOZZLE OR THE OTHER
- FLUID CONTINUOUSLY FLOWS FROM PRESSURE  $P_S$ , THROUGH BOTH INLET ORIFICES, PAST NOZZLES INTO FLAPPER CHAMBER, THROUGH DRAIN ORIFICE TO RETURN R
- THIS DIVERTS FLOW TO A OR B ( OR BUILDS UP PRESSURE IF A AND B ARE BLOCKED)

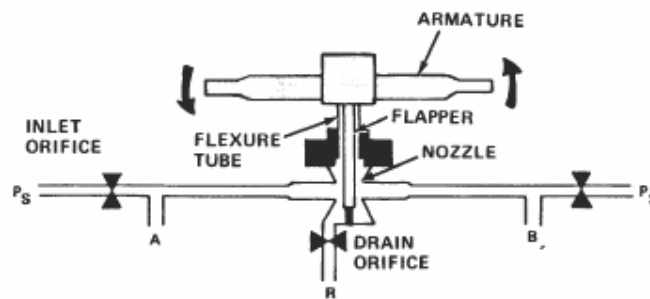
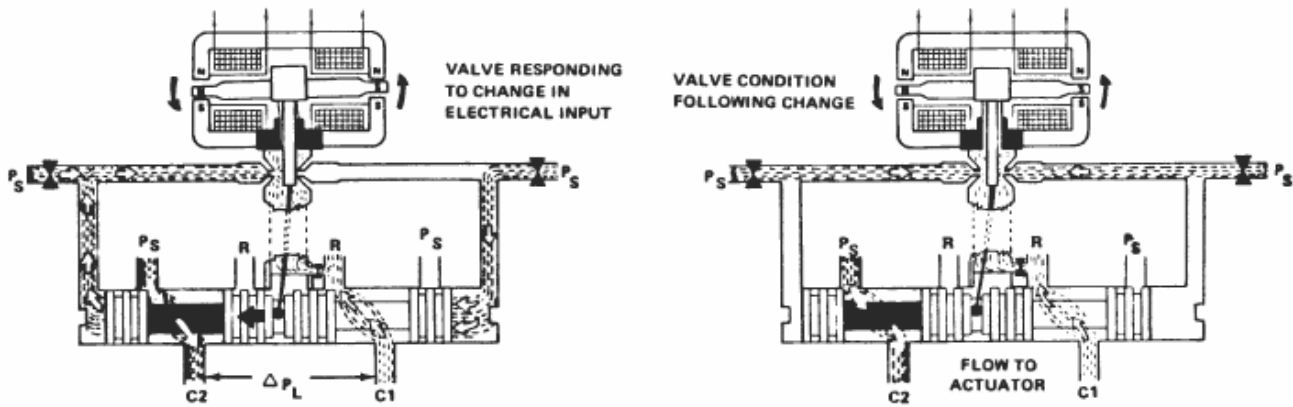
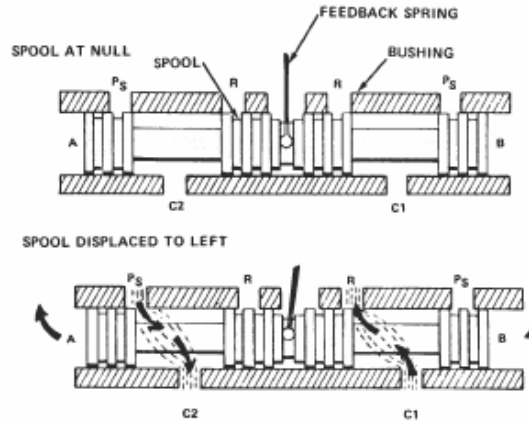

Figure 5-52. Servovalve Schematic (1 of 2)

- SPOOL SLIDES DIRECTLY IN A BODY BORE
- BUSHING CONTAINS RECTANGULAR HOLES (SLOTS) THAT OPEN TO SUPPLY PRESSURE  $P_S$  AND RETURN R
- AT "NULL" SPOOL LOBES (LANDS) ARE CENTERED BETWEEN SLOTS
- SPOOL LANDS JUST COVER OVER THE SLOTS AT NULL FOR "ZERO LAP"
- SPOOL MOTION TO EITHER SIDE OF NULL ALLOWS FLUID TO FLOW FROM  $P_S$  TO ONE CONTROL PORT, AND FROM OTHER CONTROL PORT TO R



- ELECTRICAL CURRENT IN TORQUE MOTOR COILS CREATES MAGNETIC FORCES ON ENDS OF ARMATURE
- ARMATURE AND FLAPPER ASSEMBLY ROTATES ABOUT FLEXURE TUBE SUPPORT
- FLAPPER CLOSES-OFF ONE NOZZLE AND DIVERTS FLOW TO ONE END OF SPOOL
- SPOOL MOVES AND OPENS  $P_S$  TO ONE CONTROL PORT; OPENS OTHER PORT TO R
- SPOOL PUSHES BALL END OF FEEDBACK WIRE, CREATING RESTORING TORQUE ON ARMATURE/FLAPPER
- AS FEEDBACK TORQUE BECOMES EQUAL TO TORQUE FROM MAGNETIC FORCES, ARMATURE/FLAPPER MOVES BACK TO CENTERED POSITION
- SPOOL STOPS AT A POSITION WHERE FEEDBACK WIRE TORQUE EQUALS TORQUE DUE TO INPUT CURRENT
- THEREFORE SPOOL POSITION IS PROPORTIONAL TO INPUT CURRENT
- WITH CONSTANT PRESSURES, FLOW TO LOAD IS PROPORTIONAL TO SPOOL POSITION

Figure 5-53. Servovalve Schematic (2 of 2)

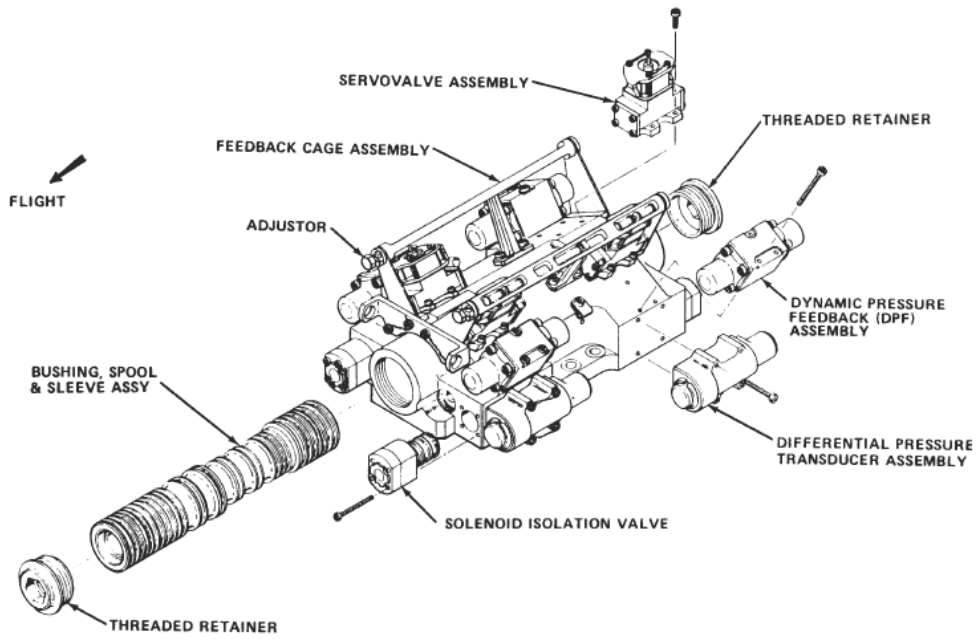

Figure 5-54. Power Valve Assembly

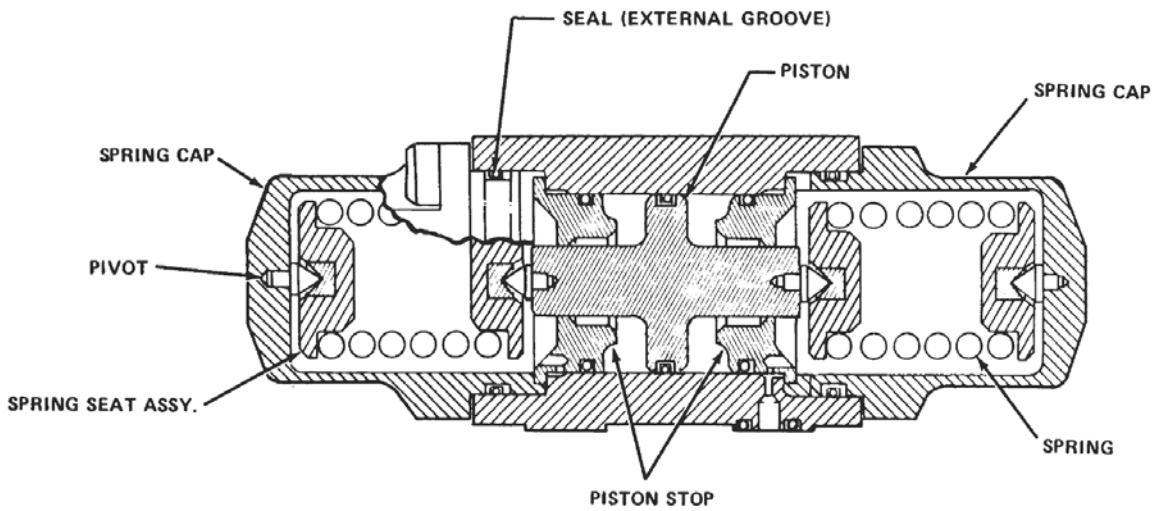

Figure 5-55. Dynamic Pressure Feedback (DPF) Assembly

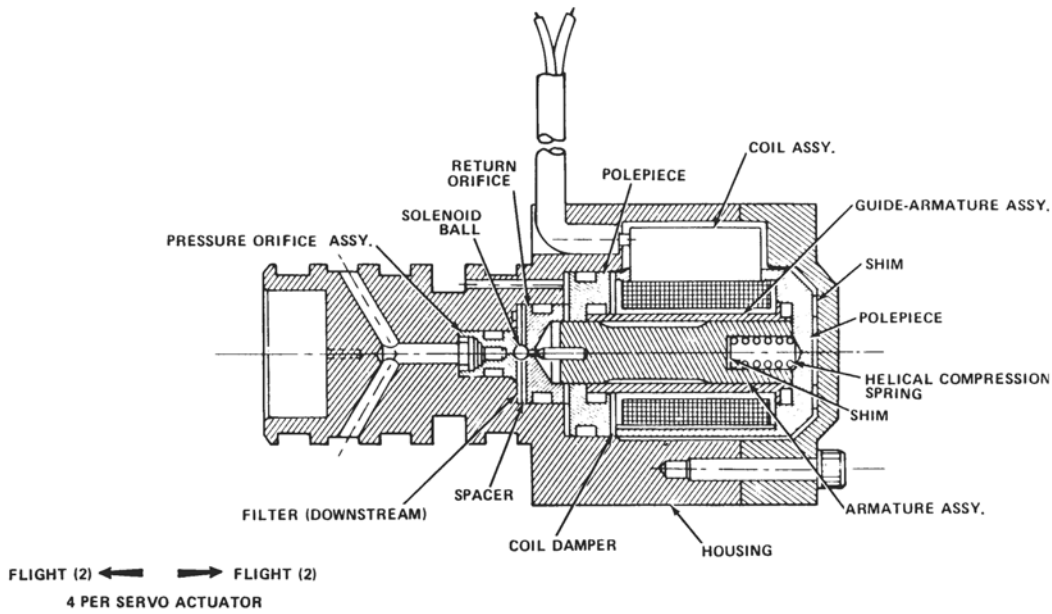

Figure 5-56. Solenoid Isolation Valve Assembly

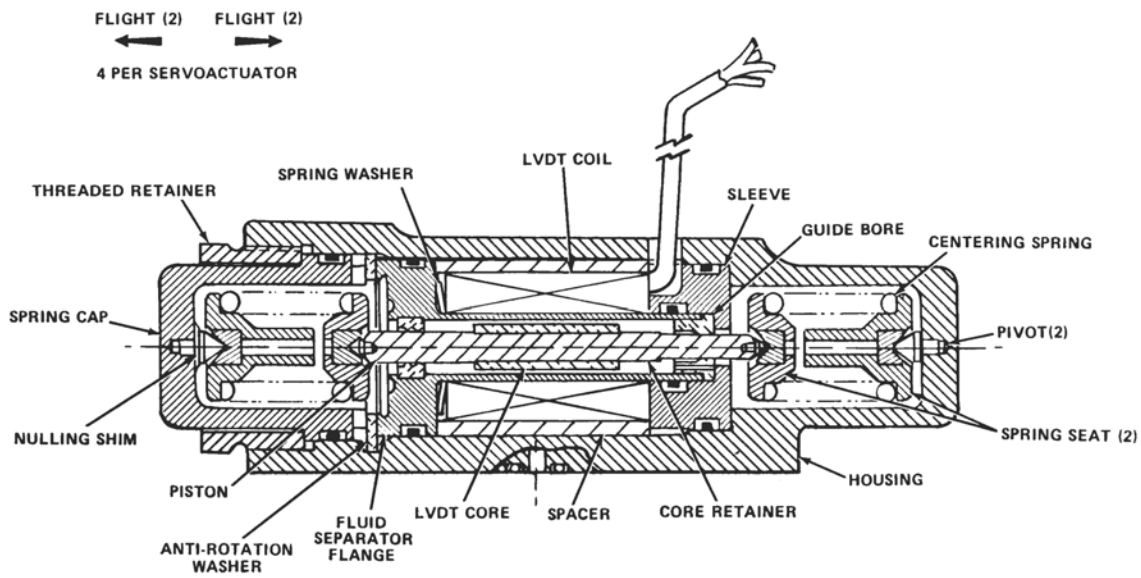

Figure 5-57. Differential Pressure Transducer

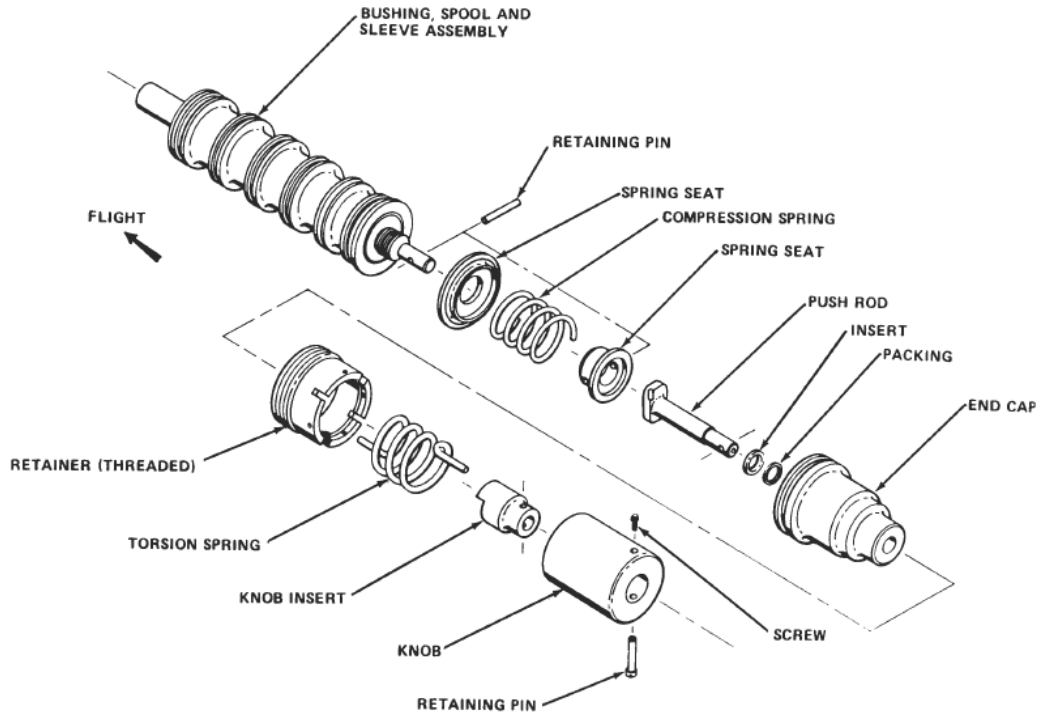

Figure 5-58. Lock Valve Assembly

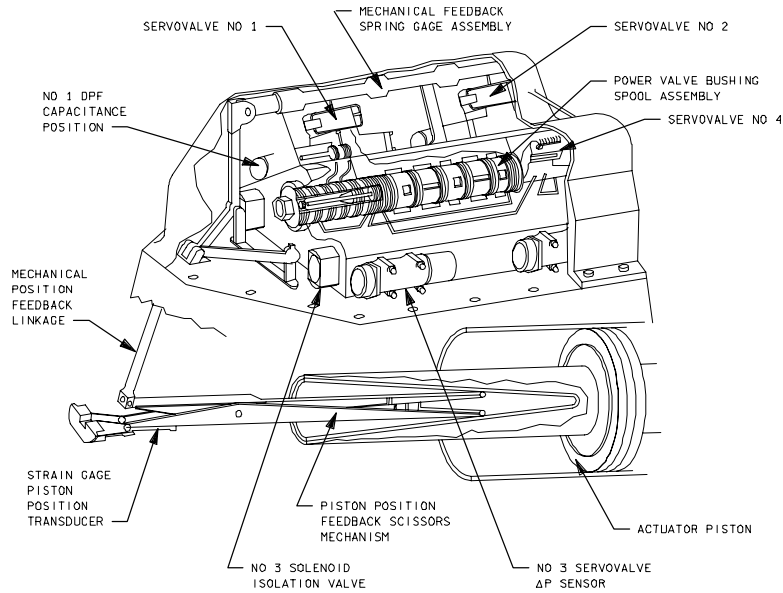
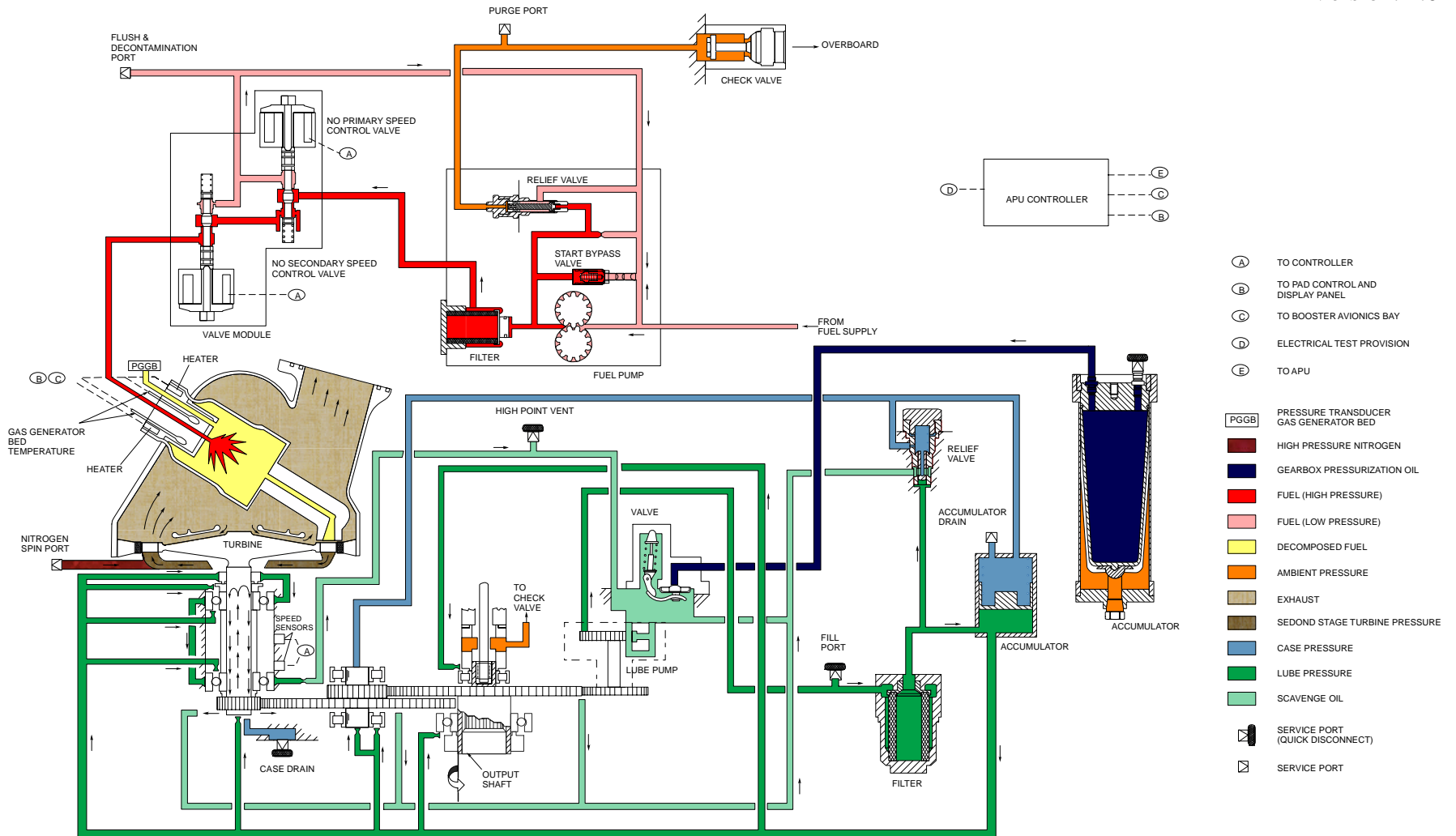

Figure 5-59. Power Valve And Feedback Configuration



Space Shuttle Auxilliary Power Unit (APU) Functional Schematic  
Figure 5-60. APU Functional Schematic

For Reference Only, March 20, 2004





Charles E. Martin  
 Senior Engineer, ERC Inc., 544-5424  
 charles.e.martin@msfc.nasa.gov



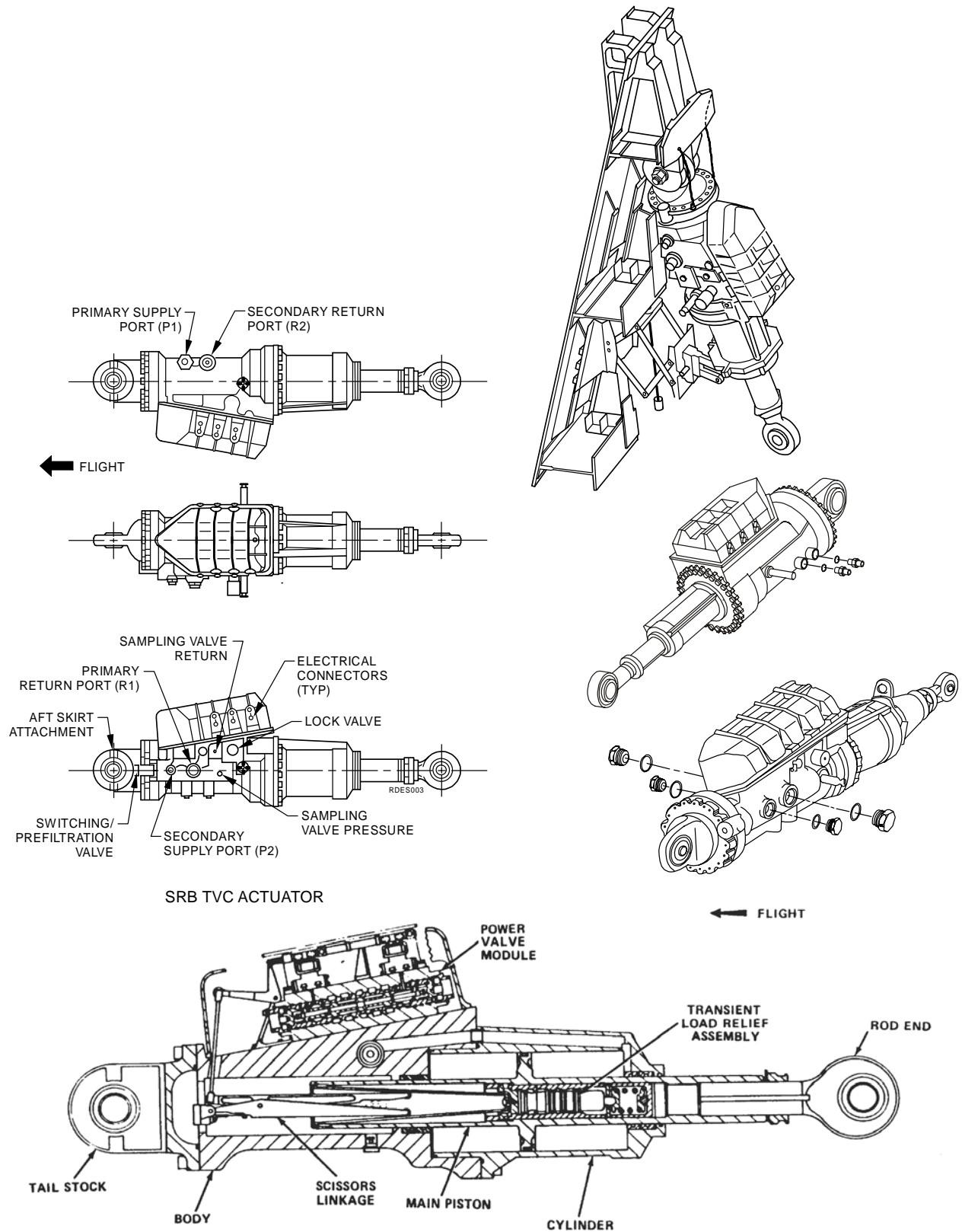

Figure 5-61 Electro-Hydraulic Servoactuator

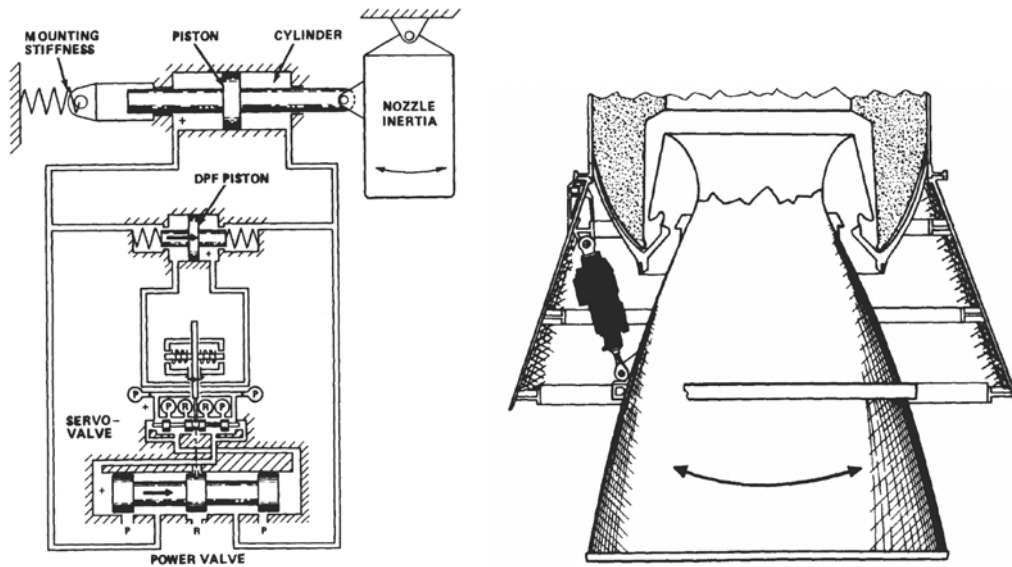

Figure 5-62. Simplified Schematic Of Thrust Vector Control Servoactuator Pressure Loop

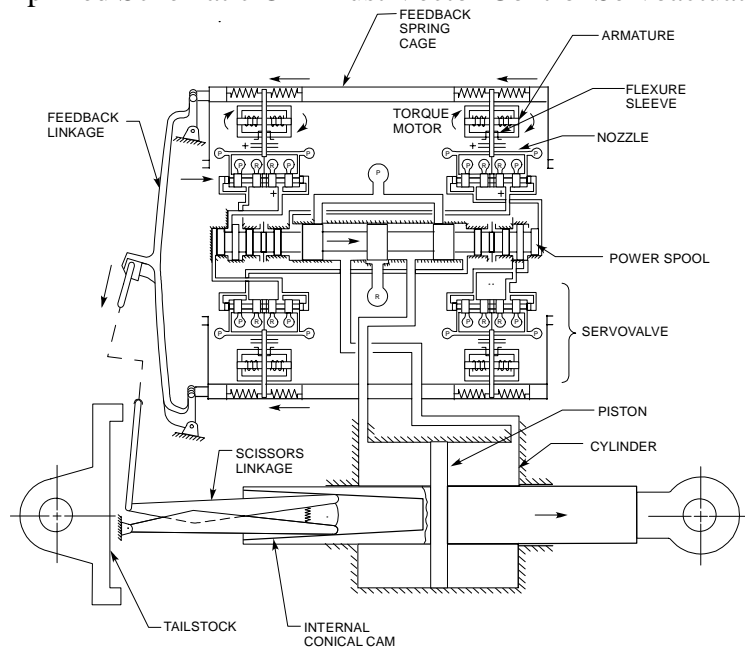
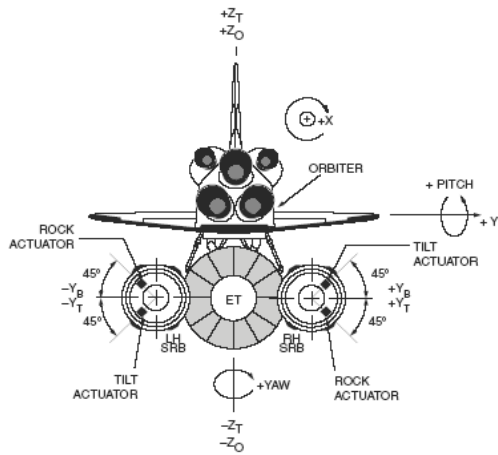

Figure 5-63. Thrust Vector Control Servoactuator Schematic



SHUTTLE VEHICLE MANEUVER	LH SRB		RH SRB	
	ROCK ACTUATOR	TILT ACTUATOR	ROCK ACTUATOR	TILT ACTUATOR
+ PITCH	-	+	+	-
- PITCH	+	-	-	+
+ YAW	+	+	-	-
- YAW	-	-	+	+
+ ROLL	+	+	+	-
- ROLL	-	+	-	+

- INDICATES ACTUATOR EXTENSION  
+ INDICATES ACTUATOR RETRACTION

Figure 5-64. SRB Thrust Vector Control Actuator Polarity

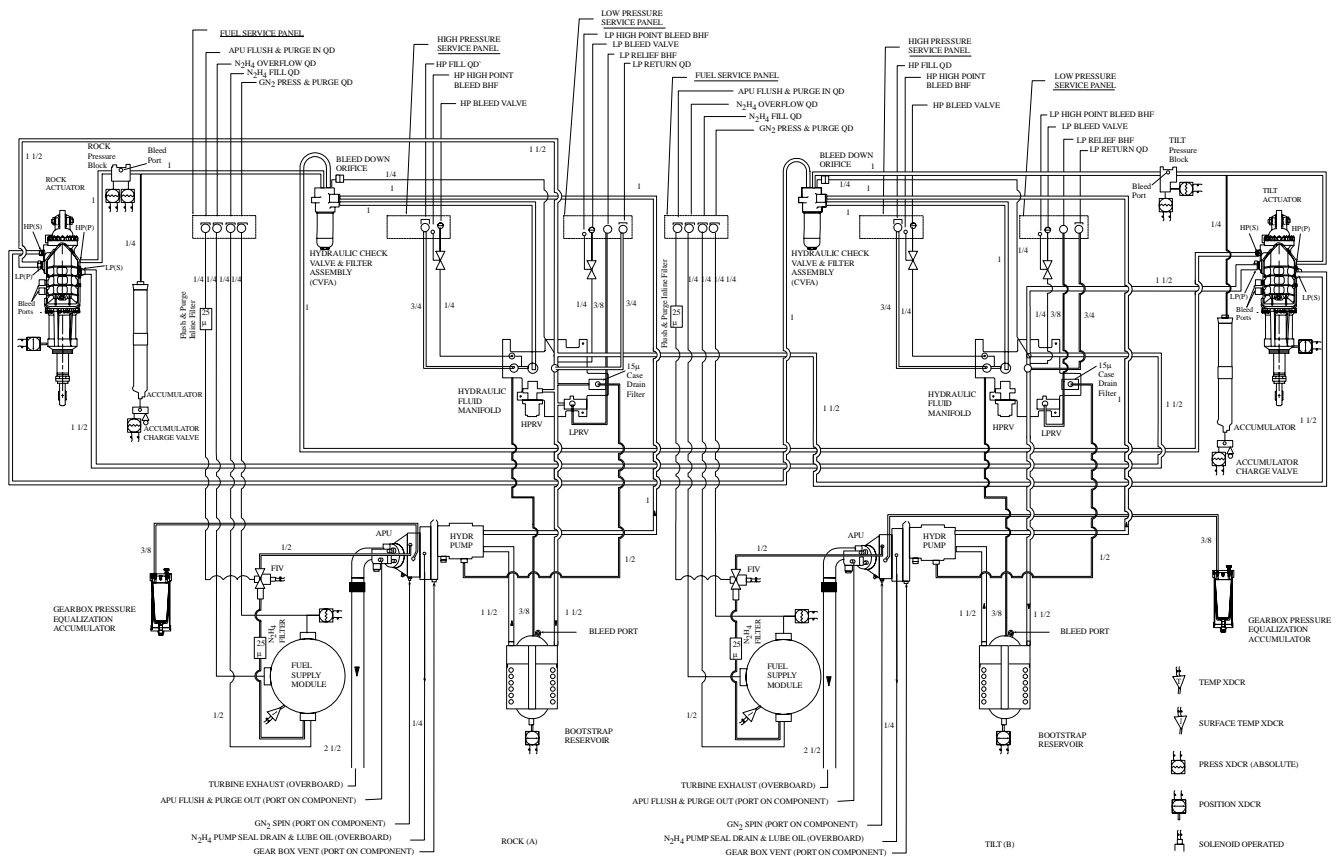

Figure 5-65. SRB TVC Subsystem Schematic

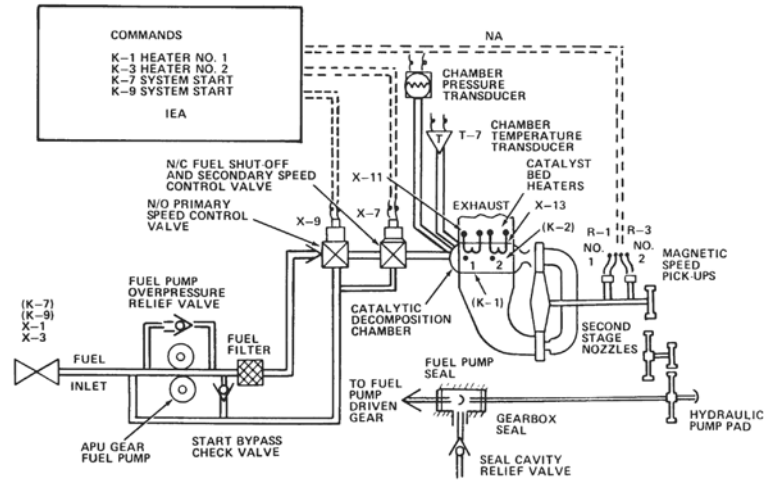

Figure 5-66. SRB TVC Controls and Measurement.

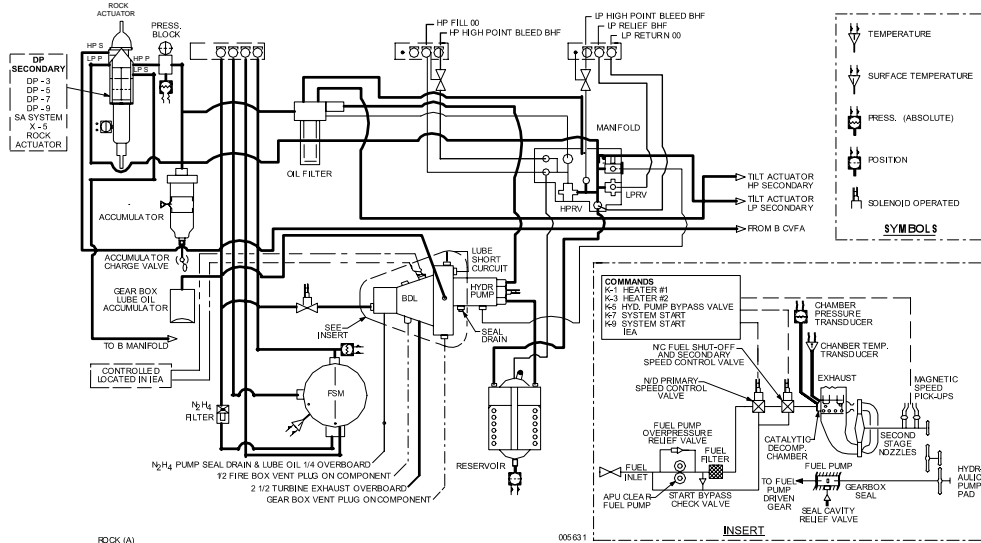

Figure 5-67. SRB APU Controls and Measurements (Rock A)

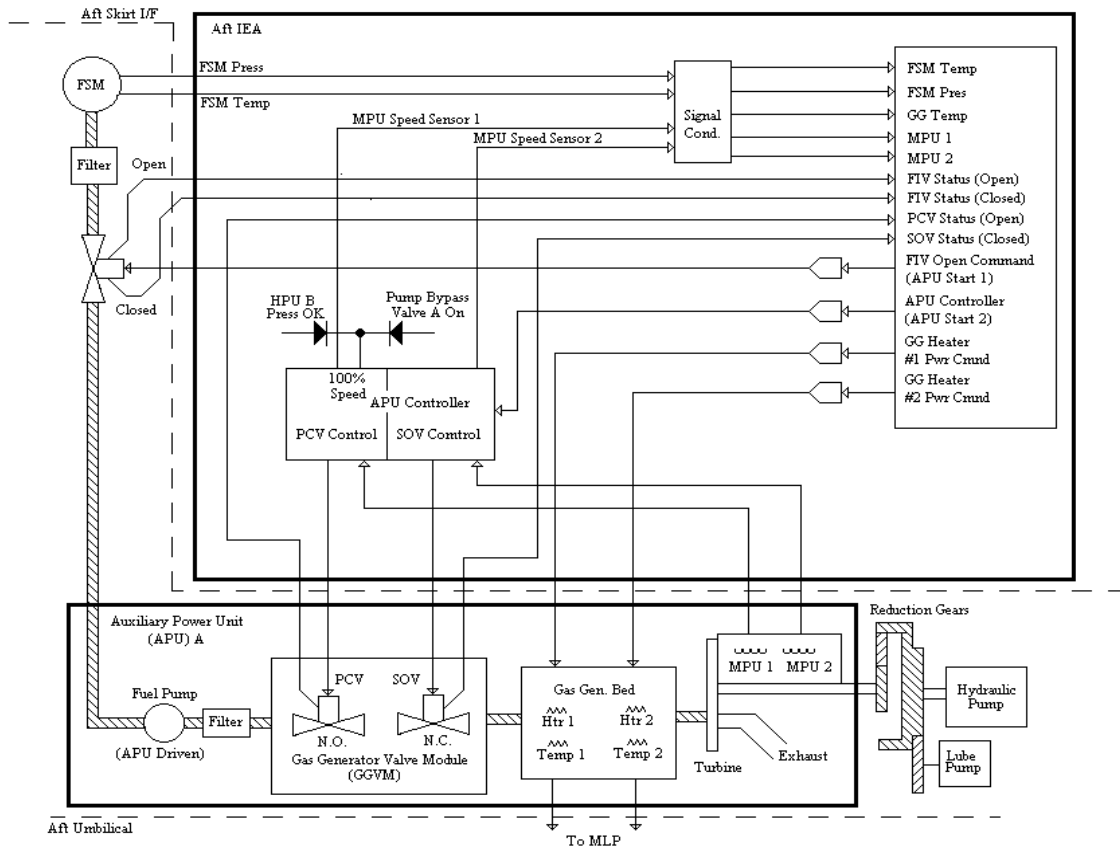

Figure 5-68. Hydrazine Control Subsystem

SRB TVC SERVOACTUATOR

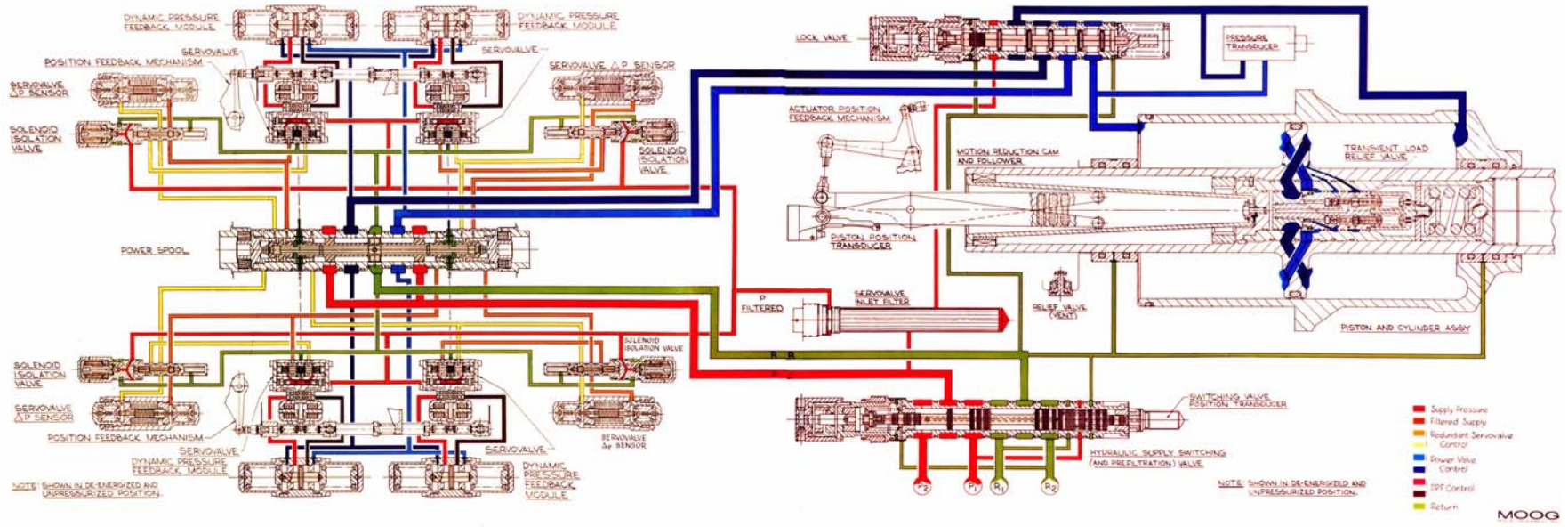

Figure 5-69. SRB TVC Actuator Schematic and Components

## 6.0 SEPARATION SUBSYSTEM

### 6.1 GENERAL

The SRB/ET separation subsystem provides for separation of the SRBs from the orbiter/ET without damage to or recontact of the elements (SRBs, Orbiter/ET) during or after separation for nominal modes. Nominal modes include conditions resulting from trajectories which include dispersions, but which preclude failures that result in mission abort. Separation of the SRBs for nominal and intact abort modes occurs only after SRB burnout. Separation is automatically inhibited if vehicle body rates and dynamic pressure exceed the design performance capability of the separation subsystem. The orbiter crew has the capability to manually override these body rates and dynamic pressure inhibits. The SRB separation subsystem provides for concurrent initiation of the structural release and Booster Separation Motor (BSM) ignition on both SRBs. The subsystem incorporates signal interlocks to prevent SRB release and BSM ignition due to stray signals. The subsystem does not produce any debris that would be damaging to shuttle elements during nominal separation modes.

### 6.2 SRB SEPARATION SEQUENCE.

At 100 seconds mission elapsed time, the separation software program is initiated by the orbiter guidance navigation and control (GN&C) computer. At this time, the GN&C computer begins sampling the output of the three SRM chamber pressure transducers mounted on the forward dome of each SRM. The separation sequence, depicted in Figure 6-1, is initiated when two of the three transducers indicate a pressure of 50 PSIA or less on both SRBs. In the event the primary pressure cue is not received, the sequence will be automatically initiated at 130 seconds mission-elapsed time. Upon receipt of the primary or backup cue, the arm command (see Figure 6-2) is issued to both the A and B subsystem (redundant) PICs on both SRBs. A time delay of four seconds has been designed into the subsystem to ensure SRM thrust of 60,000 pounds or less at separation. At 1.7 seconds prior to the end of the four-second time delay, the SRB actuators are commanded to null by the GN&C computer and the stage II flight control system (FCS) (orbiter-only rated sensors) is activated. The SRM nozzle position for actuator null is  $0.0 \pm 1.0^\circ$  from the SRB centerline in the vehicle pitch axis and  $1.0 \pm 0.50$  from the SRB centerline, toward the ET, in the yaw axis. The 1.7-second time delay is the maximum calculated time for one TVC power supply to drive both actuators to null. The actuators remain in the null position for at least five seconds after separation is commanded. At the end of the four-second time delay, the dynamic pressure and vehicle body rate inhibits are checked. If the inhibits are within the prescribed limits, orbiter attitude hold (4 seconds) is initiated and the FIRE 1 and FIRE 2 commands are issued to the SRB PICs (A & B subsystems). The orbiter crew has a manual switch to override these inhibits to command separation. The FIRE 2 command concurrently initiates structural release and BSM ignition. Release of all structural attachments occurs within 30 milliseconds and the vacuum thrust of each cluster of four BSMs reaches 29,000 pounds within 30 to 100 milliseconds of the time the FIRE 2 command crosses the orbiter/SRB interface.

### 6.3 ATTACHMENTS RELEASE.

Structural attachment separation is accomplished with double-ended, tandem piston separation bolts. NSI pressure cartridges installed in each end of the bolts provide the explosive force to fracture and separate the bolts at a predetermined fracture plane (groove). Energy absorbers are provided to contain and absorb the energy from the separating bolt halves. The forward attach configuration is shown in Figures 6-3 through 6-6.

The forward attachment is a five-inch spherical radius ball of Inconel 718 material mounted on the SRB forward skirt. The mating ET attachment is a five-inch spherical radius insert (socket) of PH13-8MC CRES steel. The insert extends down over the ball 1.56 inches, and both parts are secured with

the separation bolt torqued to  $1,000 \pm 100$  foot-pounds` (ft-lb) preload. The separation bolt and nut have 3-inch spherical radius shoulders to mate with spherical washers, and are lubricated with NPI-1220 (Vitro-Lube) to minimize bolt bending due to joint rotation.

The aft attachment consists of three struts, as shown in Figure 6-7 and 6-8, pinned at each end through a monoball bearing, that are free to rotate. The struts are tubular and made of Inconel 718 in two halves and held together by the aft separation bolt (Figure 6-9) torqued to a  $1,000 \pm 100$  ft-lb preload. The lower and diagonal struts are interchangeable. The upper strut has a flange on each mating half to provide mounting for the pull-away connectors. The flanges also provide a pivot ring to carry shear and compression loads during separation when the SRB moves in toward the ET. The structures subsystem section presents more information on the structural attachments. Additional schematic illustrating the separation supports can be found in Section 3.0 of this document.

#### 6.3.1 Electrical Disconnects.

At separation, the electrical disconnects (pull-away connectors and break-wires) at each SRB/ET structural attachment shall not induce an impulse torque in excess of 500 ft-lb-sec about the SRB center of gravity. There are two range safety system (RSS) electrical cables with pull-away connectors and one pyrotechnic cable (break-wire) crossing the forward attachment. See Section 3.0. The RSS cable connectors are mounted on brackets and held together with a Ball-Lok pin. At separation, as the SRB moves away from the ET fitting, a lanyard, tied to the SRB and the Ball-Lok pin, activates the pin and allows the two mounting brackets to separate. Further movement of the SRB then pulls the connectors apart. A 100-pound pull on the Ball-Lok pin is required to release the pin.

There are six SRB to orbiter cables and one pyrotechnic cable, with pull-away connectors crossing the separation plane of the aft upper strut. There is one pyrotechnic cable crossing the separation plane of each of the lower and diagonal struts, which is broken at separation. All cables are protected from aerodynamic and thermal loads by fairings.

#### 6.3.2 Separation Bolts.

Separation of the forward and aft structural attachment is accomplished with double-ended, tandem piston, pyrotechnically actuated separation bolts. The forward and aft separation bolts are functionally identical but are of a different size due to the load carrying requirements. There are NSI pressure cartridges installed in each end of the bolts, either of which will fracture and separate the bolt at the predetermined fracture plane (groove). The NSI pressure cartridge, an electro-explosive device, is actuated by a capacitive discharge from the PICs. The separation bolts function within 10 milliseconds from the time the electrical charge is received at the NSI. The bolts are designed to separate without producing debris.

The forward separation bolts are designed to carry 189,000 pounds of tension and 55,344 in-lb bending load.

The aft bolt has been qualified to a design load of 393,000 pounds of tension.

### 6.4 BSM GENERAL.

The BSMs provide the force to translate the SRBs away from the orbiter/ET at separation. The BSMs were positioned on the SRB so as to minimize plume and particle impingement on the orbiter. The BSMs are installed in a four motor cluster in the frustum and on the aft skirt as shown in Figures 6-10, through 6-17. At both locations, the resultant dynamic thrust vector of the BSM cluster is parallel



within  $\pm 4^\circ$  to a plane containing the SRB centerline, which is rotated about the centerline toward the ET  $20^\circ$  from the SRB + Z-axis. The resultant thrust vector of the forward cluster passes within 2.6 inches of the SRB centerline. The thrust vector of the aft cluster is offset  $1.95 \pm 3.9$  inches from the SRB centerline toward the ET in a direction normal to the  $20^\circ$  plane. This 1.95-inch offset is caused by the unsymmetrical installation of the four motors about the  $20^\circ$  plane. The dynamic thrust vector of each cluster is pitched in the  $20^\circ$  plane  $40 \pm 2.0^\circ$  from the SRB Y-Z plane. The forward cluster is pitched forward and the aft cluster is pitched aft.

The BSM design, shown in Figure 6-18, has a diameter of 12.865 inches, a length of 31.0 inches, and a  $20^\circ$  canted nozzle. The canted nozzle was required to permit installation in the frustum. It also allows a low profile installation on the aft skirt that reduces the drag loads. The maximum weight of the BSM is 167 pounds, which includes CDF initiators, pressure transducers, plug, and the aft heat seal.

The BSM is designed to produce a specified performance over a propellant bulk temperature range of  $30$  to  $120^\circ$  and at vacuum conditions. The average minimum (-3 sigma) thrust is approximately 18,500 pounds, and the average minimum (-3 sigma) total impulse is 15,000 pound-seconds (lb-sec). The BSM ignition interval is within 30 to 100 milliseconds.

The requirement that the BSM produces no debris that would be damaging to the orbiter TPS tiles has been a significant design driver. The following considerations were used in the design to meet this requirement:

- a. The BSMs were canted away from the orbiter.
- b. The web action time was limited to 0.8 seconds.
- c. The ignition interval and tail-off time are constrained to minimize total burn time and residual thrust.
- d. The plume size is reduced by using a neutral or regressive thrust time trace and by limiting the chamber pressure at-the end of burn to 2,000 PSIG.
- e. The nozzle is contoured to minimize gaseous and particulate plume expansion.
- f. The motor and igniter propellant burn rate and stability additives were limited to 1 percent and 2 percent, respectively.
- g. The propellant grain shape was designed to minimize generation of unburned propellant slivers.
- h. Material selections were based on the lowest potential for producing debris.

#### 6.4.1 BSM Case.

The case (cylinder and forward dome) is a one-piece structure that is reverse-extruded and drawn from a 7075 aluminum forging. Machining is required to provide dimensional control. The overall case length is 25.83 inches, with a 0.315 inch minimum wall thickness. The forward end of the case has eight threaded holes and a guide pin to provide an alignment interface to the SRB. Twenty-four equally spaced holes on the aft end provide mounting provisions for both SRB cluster locations.

#### 6.4.2 BSM Nozzle/Aft Closure Assembly.

The nozzle/aft closure assembly is comprised of an aft closure, a closure insulator, a throat insert, and an exit cone. The aft closure is made from a one-piece forging of 7075 aluminum that is machined along the surfaces that interface with other components. The nozzle throat has a diameter of 3.133 inches and is made of ATJ graphite to provide excellent reliability while virtually eliminating ejecta from the throat region. The exit cone is carbon steel machined to the desired geometry and threaded to interface with the aft closure. The graphite portion of the nozzle is carried to an expansion ratio of 1.7 to preclude melting of the steel exit cone. The exit cone provides an expansion ratio of 5.8 and has

been contoured to provide minimum expansion of the gaseous and particulate plume during tail-off. The nozzle is canted at 20° to the motor centerline to provide the desired dynamic thrust vector during separation. The nozzle/aft closure assembly is attached by threads to the motor case. A molded NBR insulator is used to protect the aft-closure, as well as to maintain a maximum 290°F case wall temperature during soak-out. The closure is aligned to the nozzle centerline and secured by an alignment pin at the case interface. Where dissimilar metals are involved, cadmium plating protection eliminates the possibility of galvanic corrosion.

#### 6.4.3 BSM Propellant.

The propellant grain is a 16-point star configuration that provides the desired thrust-time history. Each star point has a flared base to provide structural support throughout burning to prevent the propellant from breaking off and being ejected from the motor. The propellant to be used for the BSM, UTP-19048, is a fully characterized hydroxyl terminated polybutadiene (HTPB) type. The formulation has 86 percent solids, including 2 percent maximum aluminum and 0.25 percent nominal (0.40 percent maximum) Fe2O3.

#### 6.4.4 BSM Case Liner.

The liner for the ESM, UTL-0040, is specifically formulated for use with HTPB propellants. Bond tests with UTP-19048 have shown that UTL-0040 provides a bond that is stronger than the propellant and thus is capable of offering the high reliability needed for this system. The liner serves as the case wall insulator.

#### 6.4.5 BSM Igniter.

The design consists of a simple perforated steel tube containing UTP-19048 propellant cast on a steel rod in an external eight-point star configuration. Forward of this is a small initiator charge containing 3 grams of BKNO3 granules that is triggered by two (redundant) confined detonating fuse (CDF) initiators.

#### 6.4.6 BSM Covers.

Nozzle covers are required to protect the propellant from the thermal environments during ascent. The forward motors are subjected to aerodynamic heating; the aft motors are subjected to SRM radiation heating and SSME radiation and plume heating. The forward motor cover is a hinged metal cover constrained during boost by a frangible link designed to fracture at motor ignition. The hinge pin provides structural support for the motor cover and ratchet assembly. A ratchet assembly has been incorporated in the hinge that locks the cover (shown in Figure 6-19) in the open position after separation. The aft motor cover is made of aluminum and is blown off at BSM ignition. The aft cover requires external insulation (Figure 6-20).

#### 6.4.7 BSM Ignition.

The BSM ignition system consists of redundant NASA standard detonators (NSDs), CDF manifolds, CDF assemblies, and CDF initiators. These pyrotechnic components are activated by a capacitive discharge from redundant PICs.

#### 6.4.8 BSM Thermal Protection.

The BSM TPS uses cork, RT455, and BTA. These insulations are used to hold the case temperature down to 190°F.

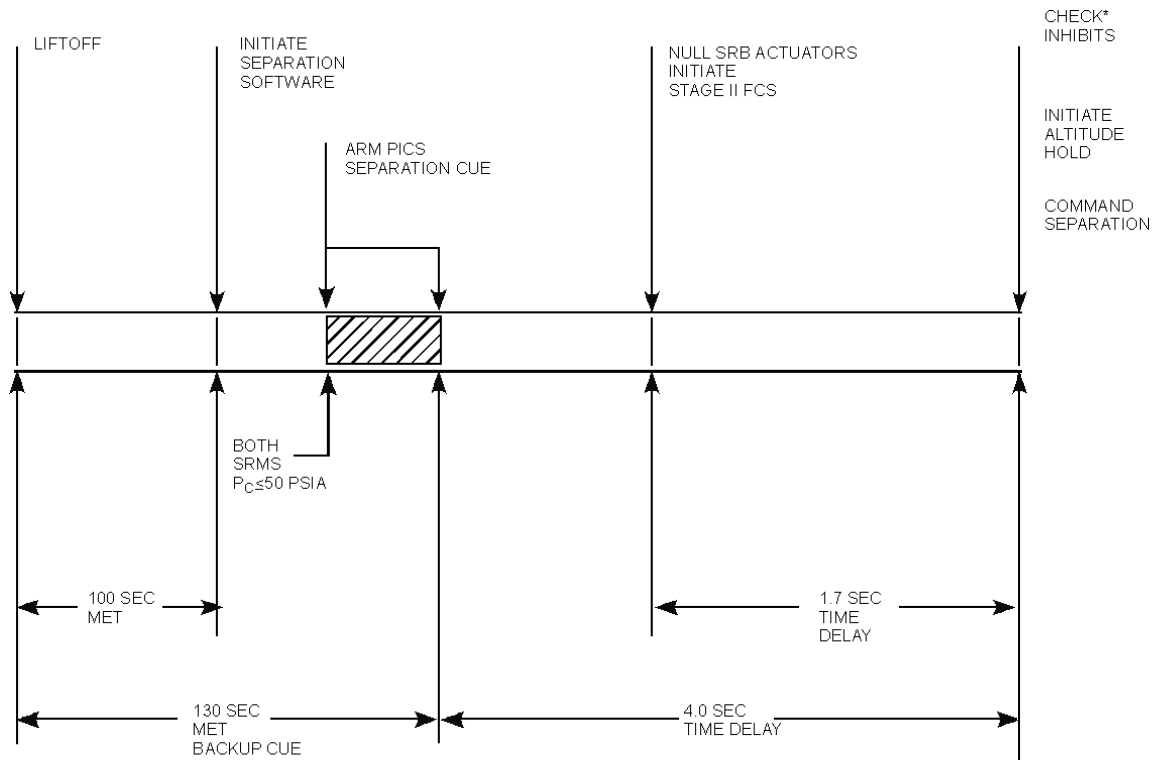

\*INHIBITS ARE A FUNCTION OF BODY RATES AND DYNAMIC PRESSURE

Figure 6-1. SRB Separation Sequence

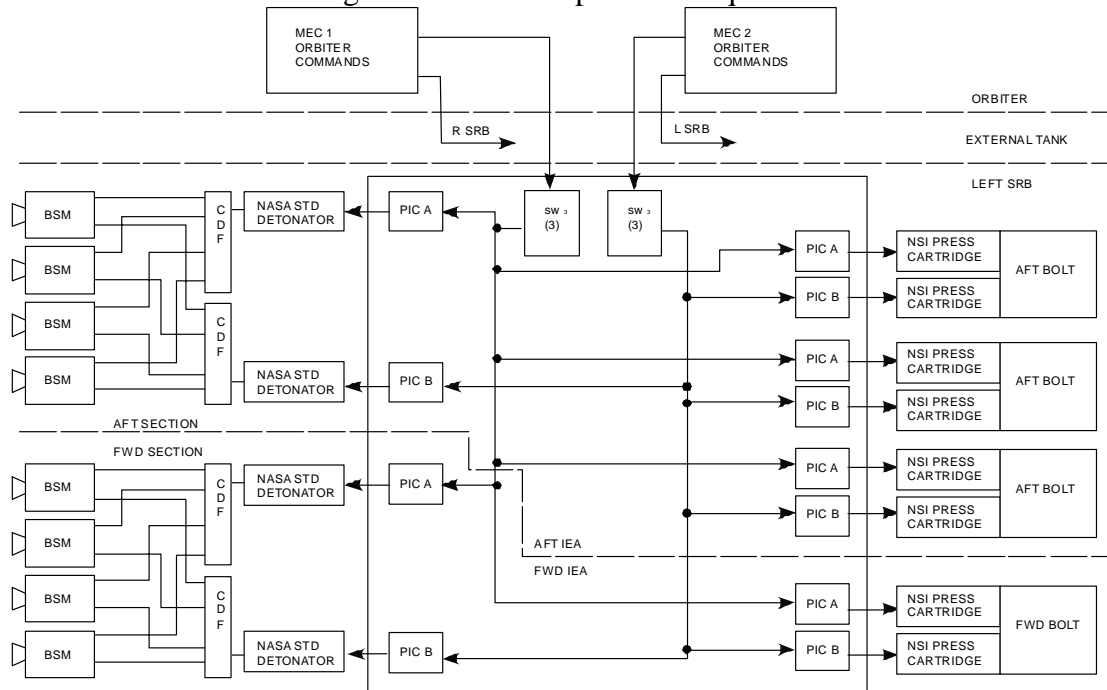

Figure 6-2. BSM Ignition and SRB Structural Release Subsystem

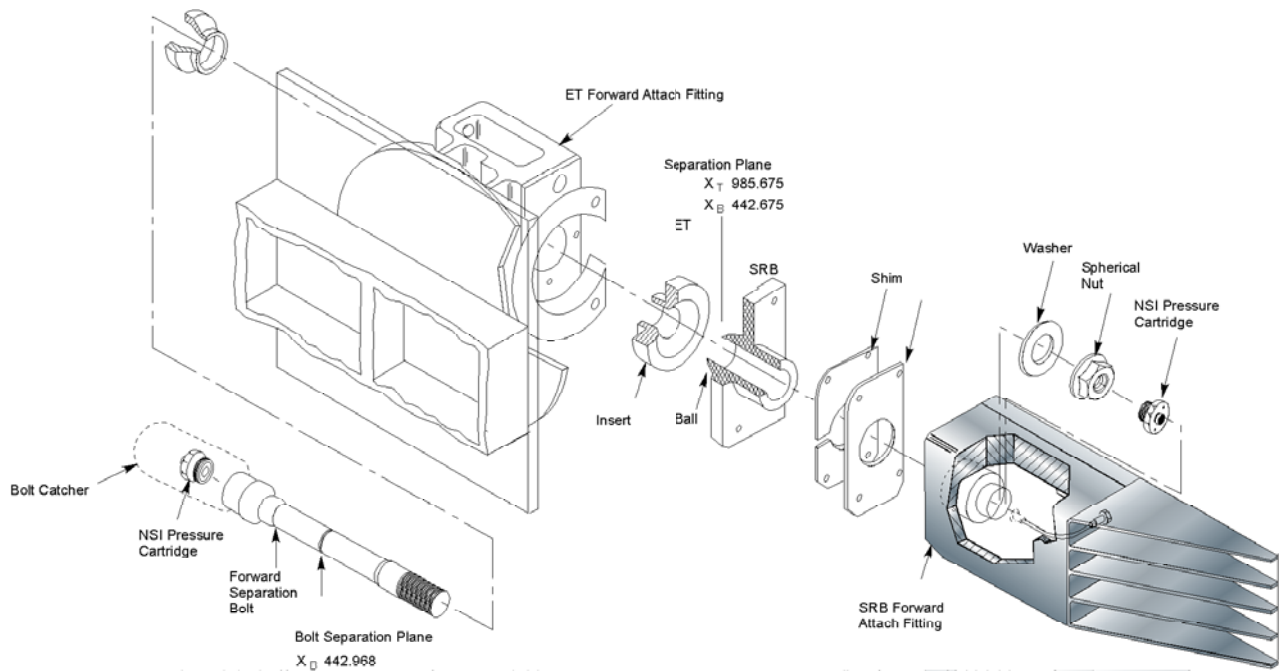

Figure 6-3. SRB/ET Forward (RH) Attach Fitting Exploded view

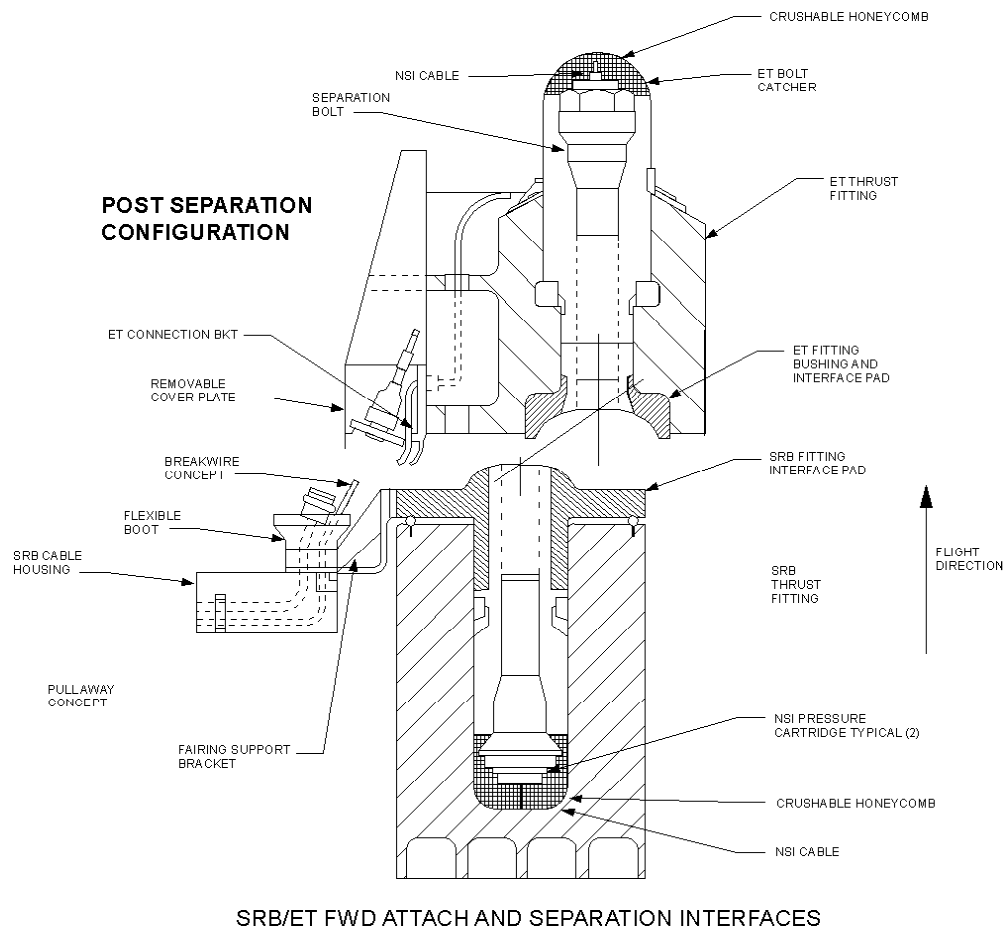

Figure 6-4. SRB/ET Upper Attach Bolt Separation Plane

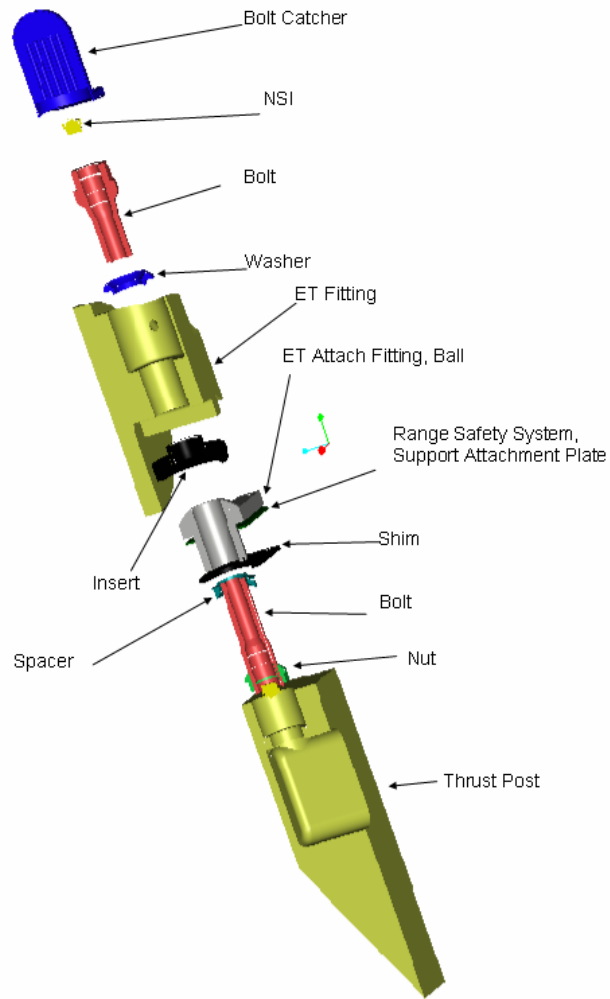

Figure 6-5. SRB/ET Fwd Attach & Separation Interfaces

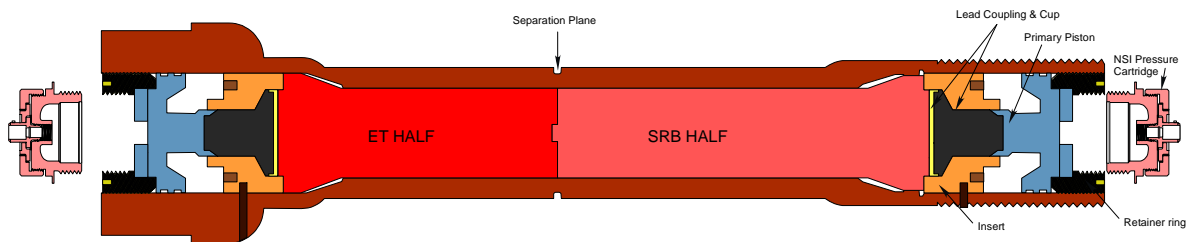
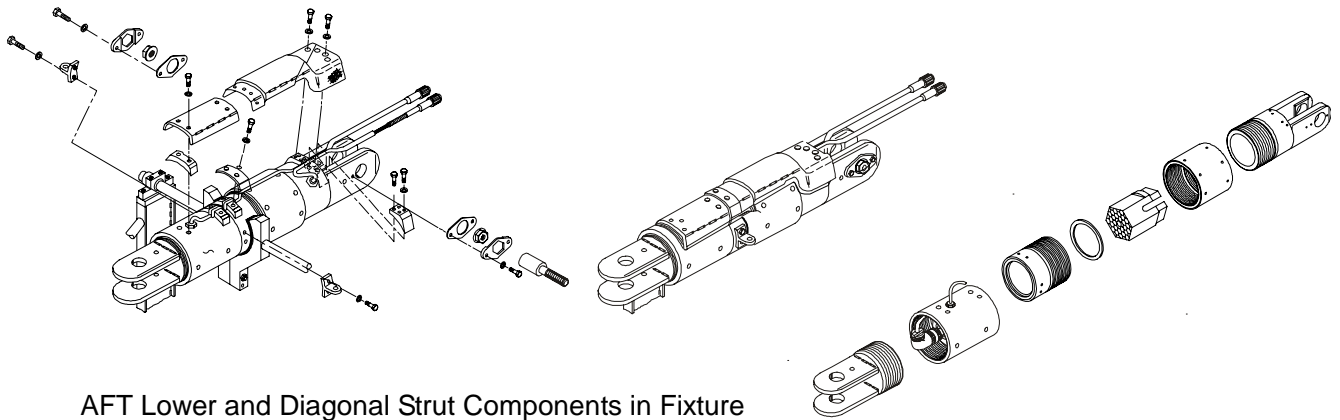

Figure 6-6. Forward SRB/ET Separation Bolt



AFT Lower and Diagonal Strut Components in Fixture

Figure 6-7. SRB/ET Lower and Diagonal Attach Strut Expanded View

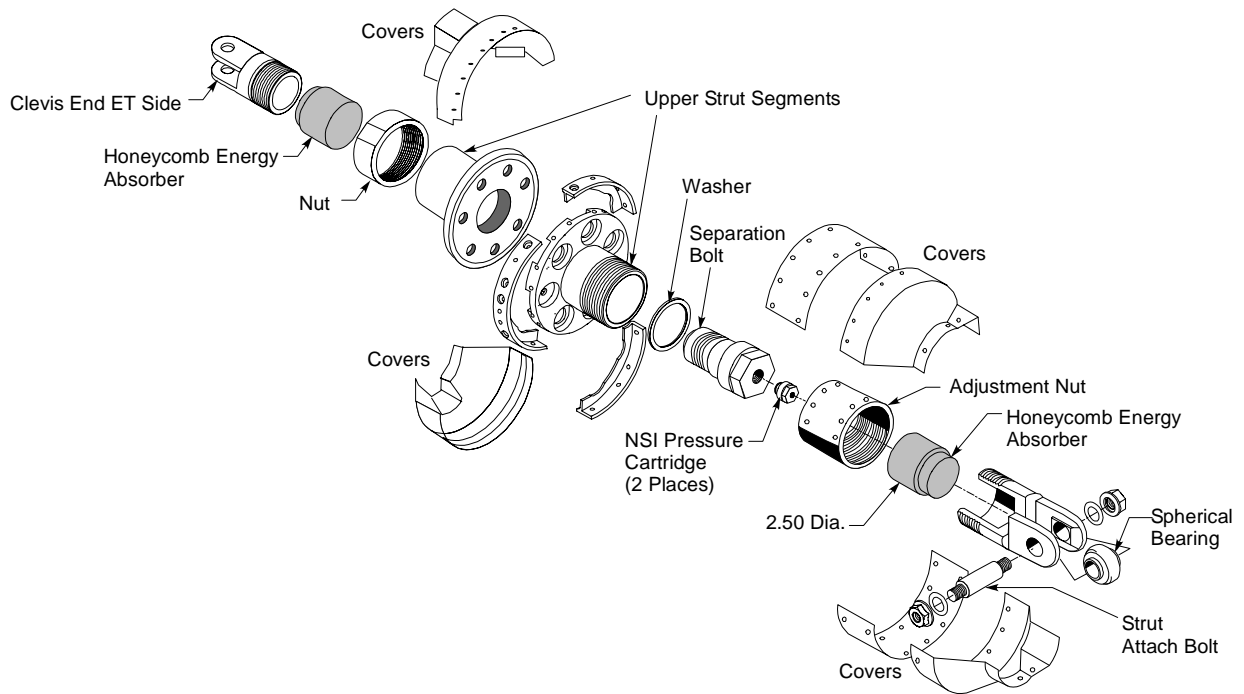

Figure 6-8. SRB/ET Upper Attach Strut Exploded View

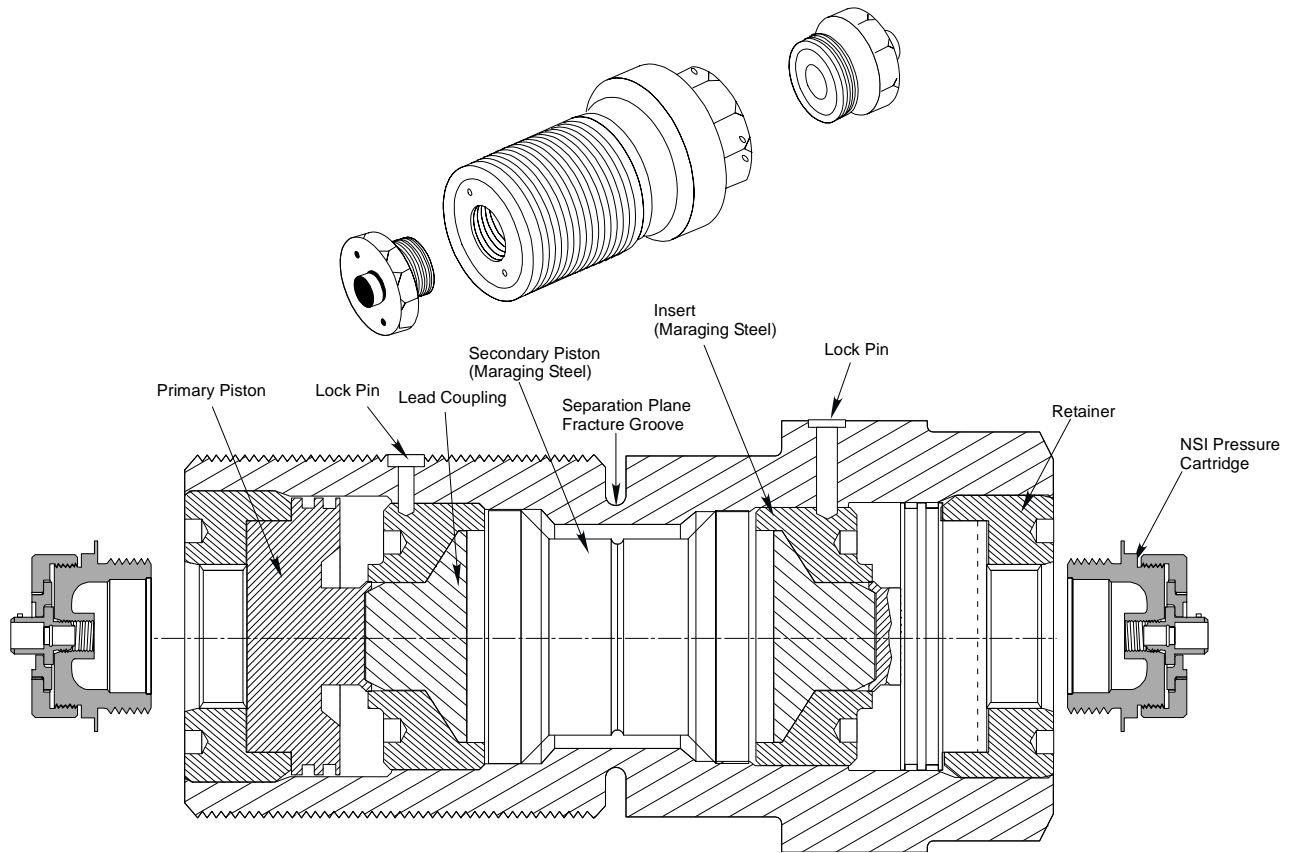

Figure 6-9. Aft Separation Bolt Assembly

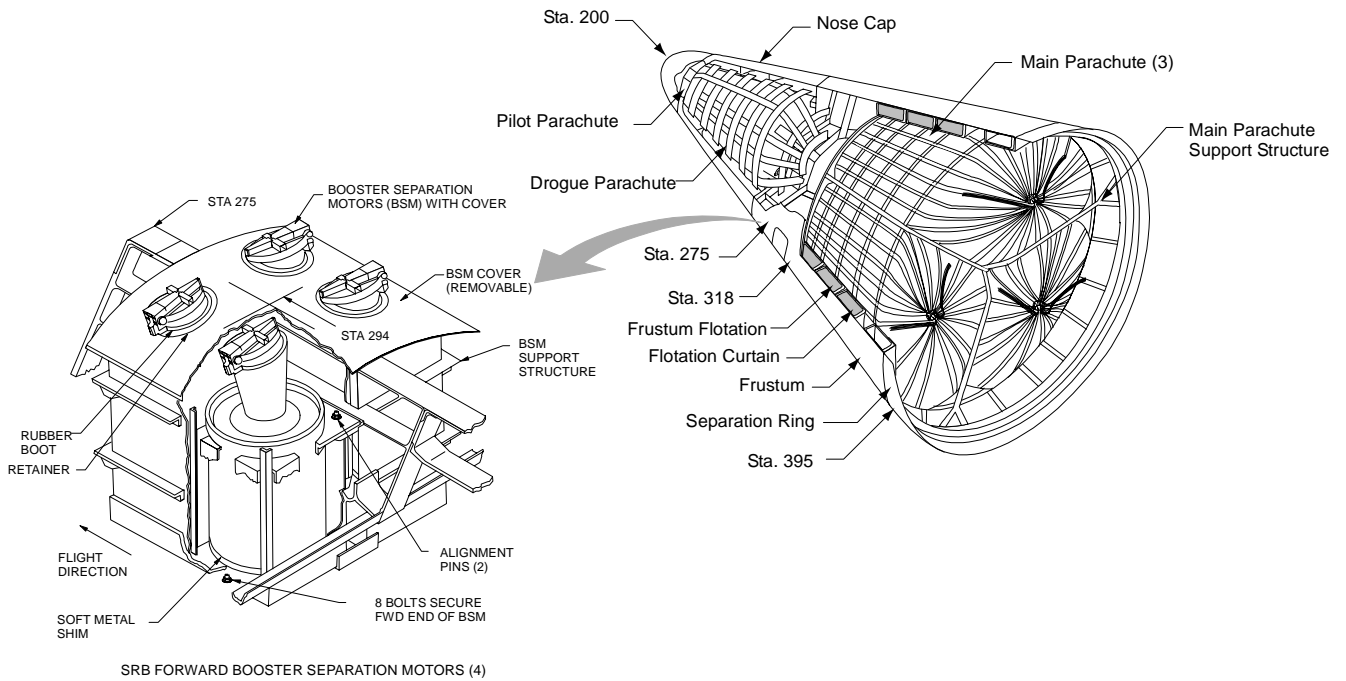

Figure 6-10. Forward Booster Separation Motors Schematic

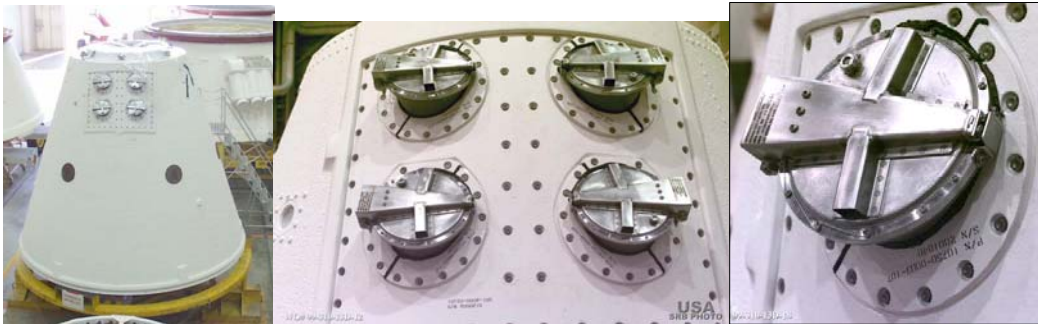

Figure 6-11. Forward Booster Separation Motors Pictures Showing Covers

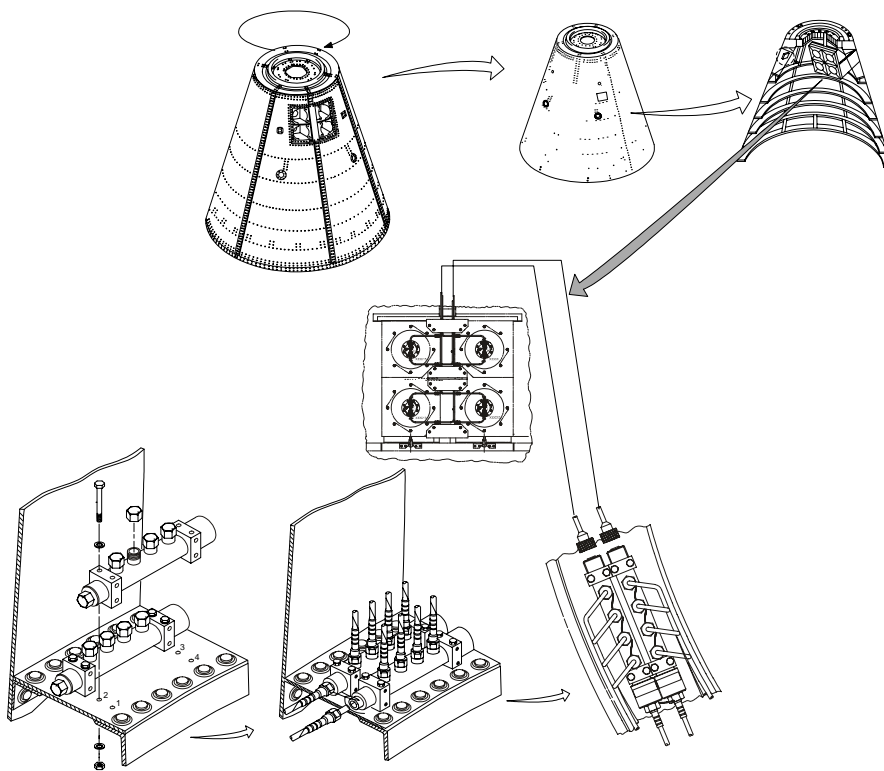

Figure 6-12. Forward BSM Details and CDF Manifold



Figure 6-13. Forward BSM Ignition CDF Manifold



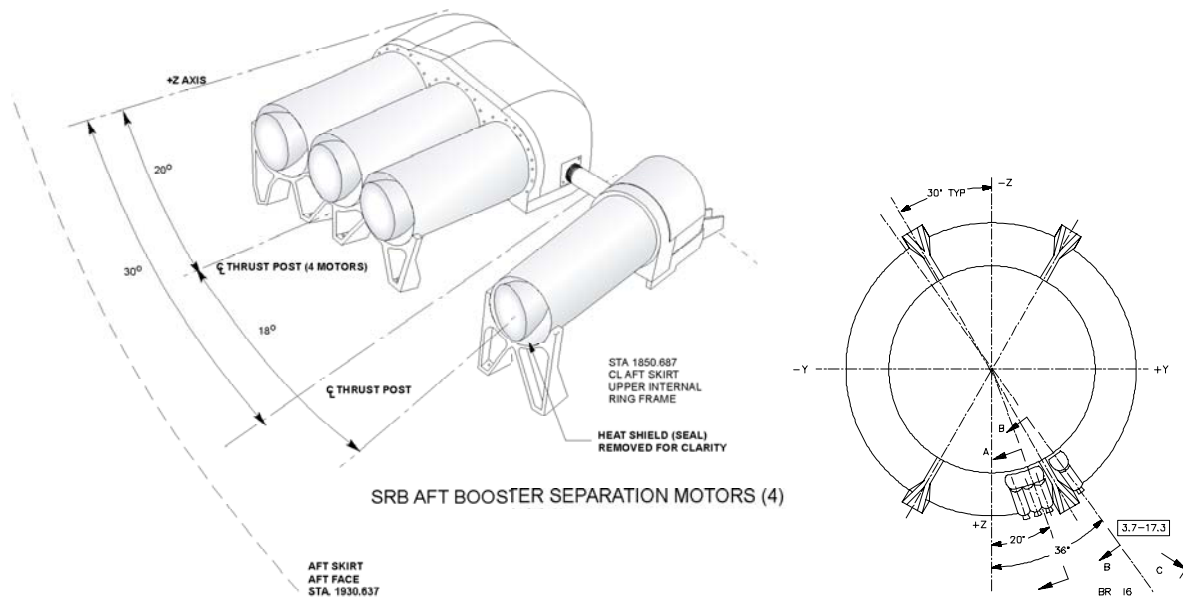

Figure 6-14. SRB AFT BSM Orientation on Aft Skirt

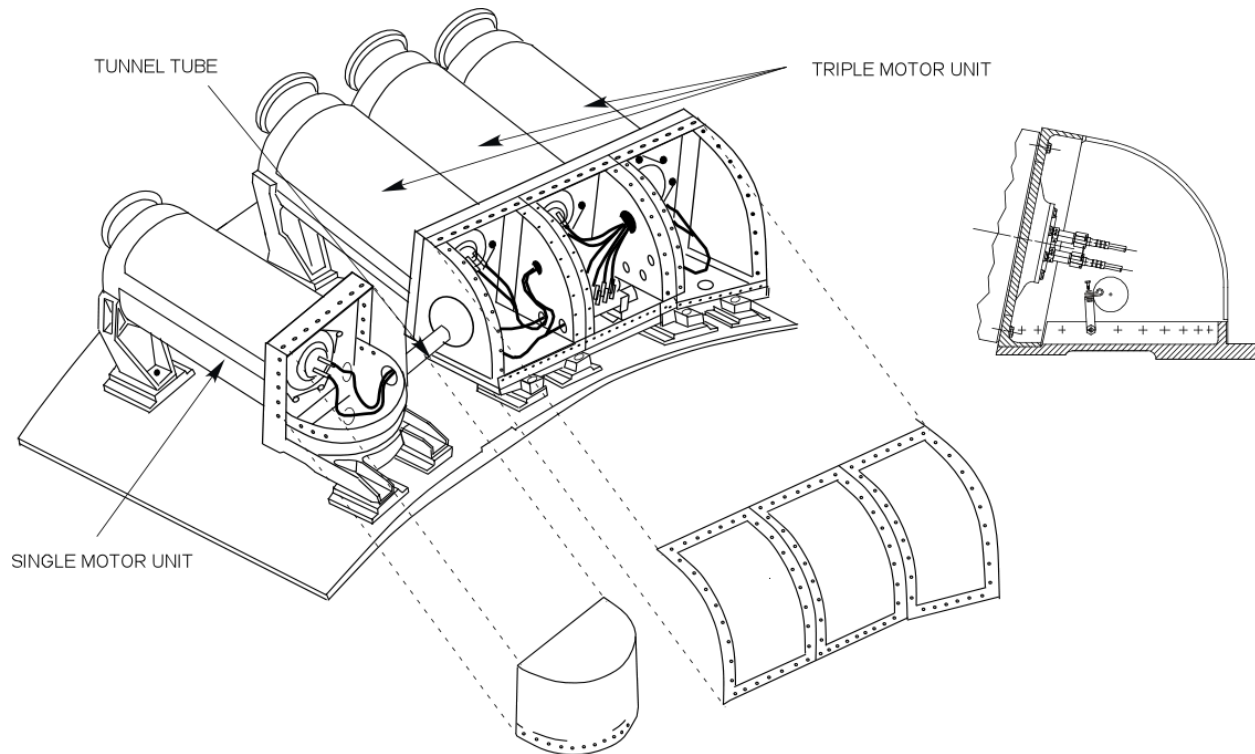
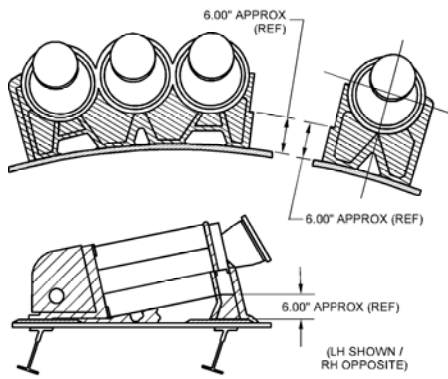
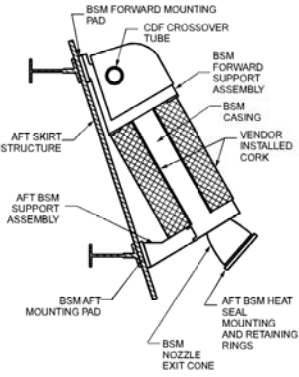

Figure 6-15. AFT BSM Alternate Configuration Showing Covers



BSM SUPPORTS INSULATION INSTALLATION  
REFERENCE LOCATIONS



BSM TERMINOLOGY

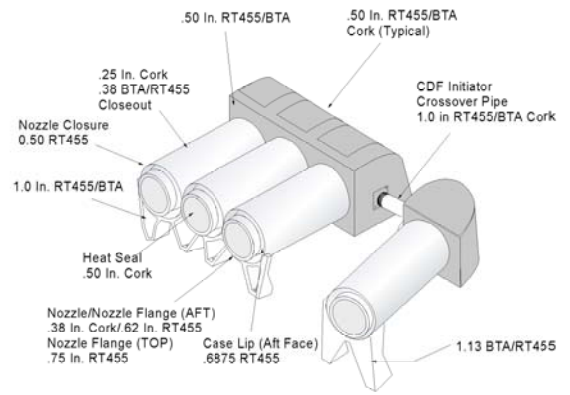

Figure 6-16. AFT BSM Details



Figure 6-17. Aft BSM Cluster Showing Insulated and Non-Insulated Configuration

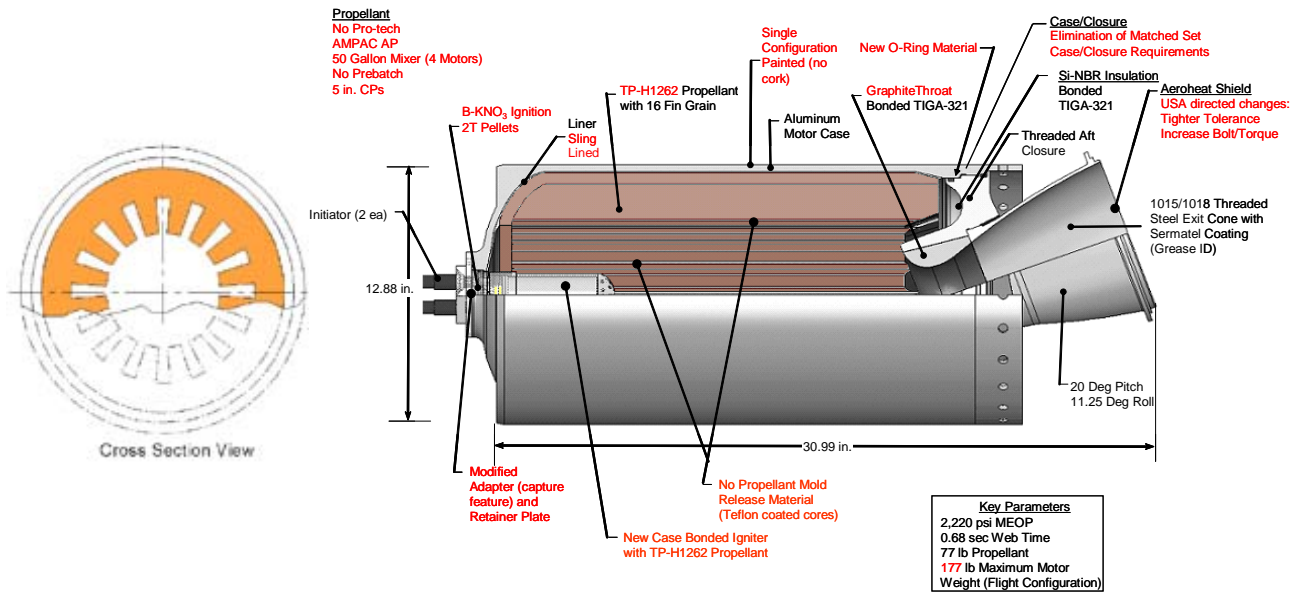

Figure 6-18a. SRB BSM Section View

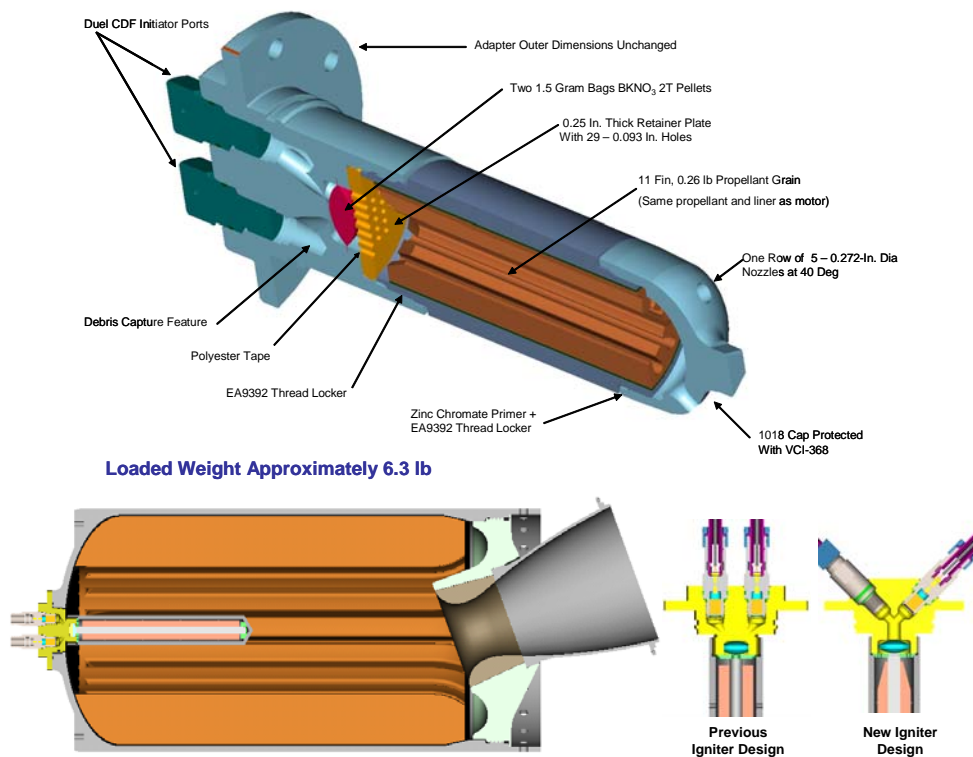

Figure 6-18b. SRB BSM Showing Igniter Re-design



Figure 6-18c. BSM Nozzle and Throat Cutaway

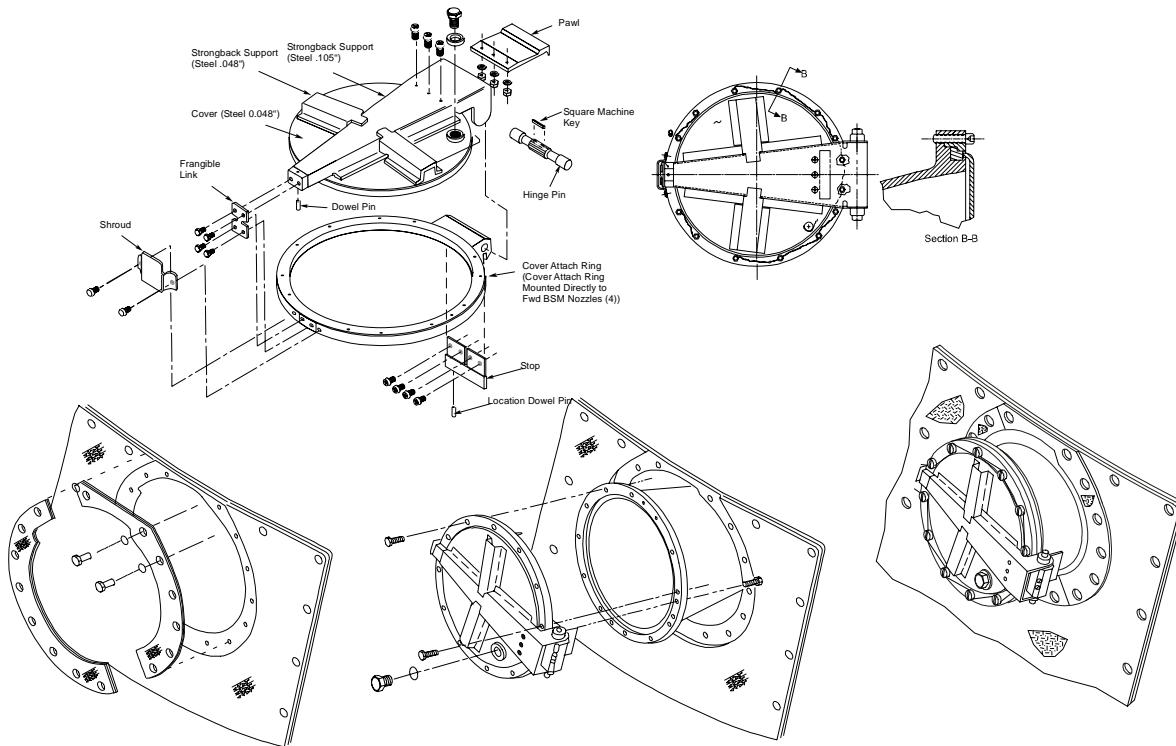

Figure 6-19. Forward BSM Nozzle Cover

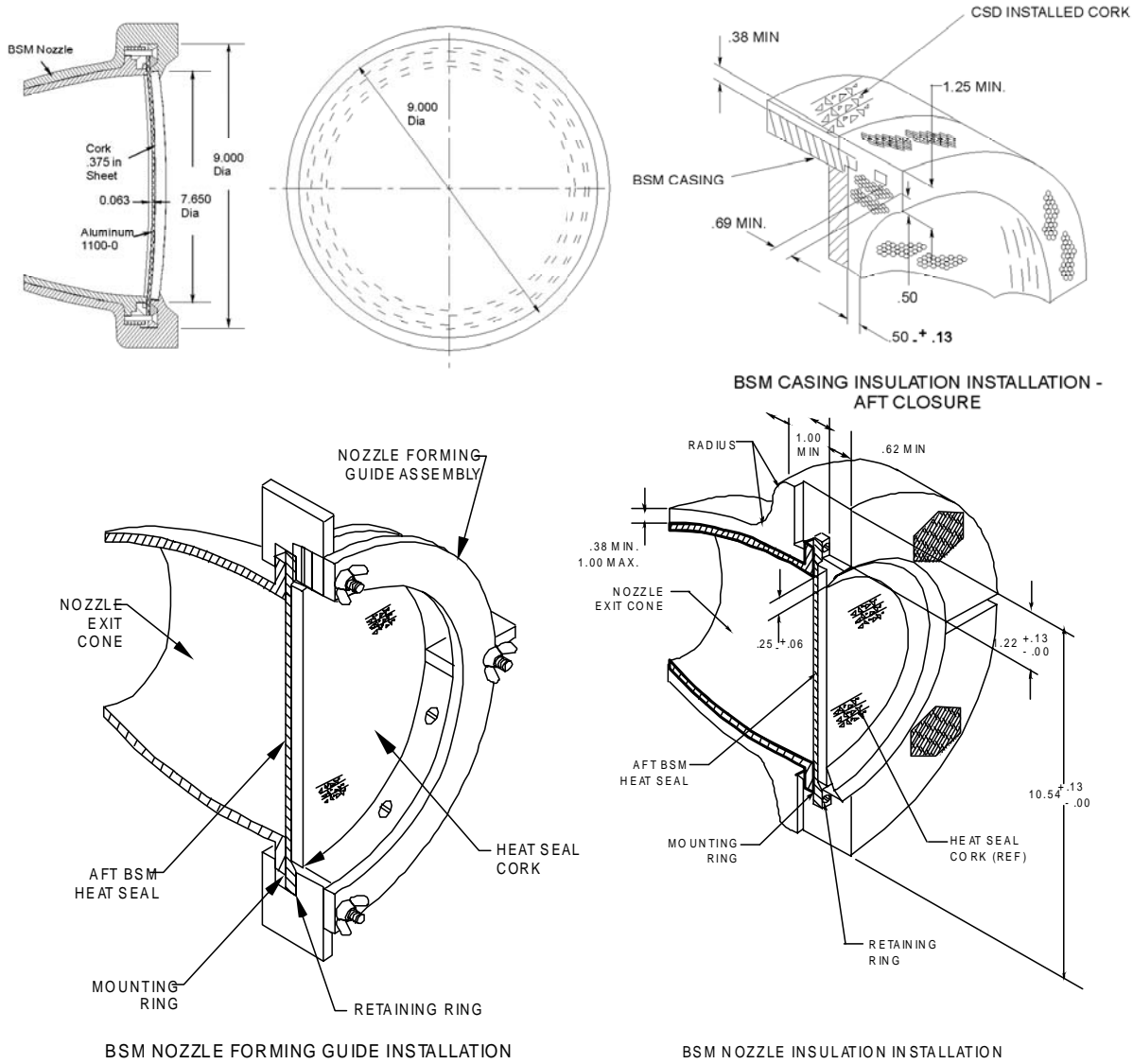

Figure 6-20. AFT Booster Separation Motors Heat Seal Configuration

## 7.0 SOLID ROCKET BOOSTER RECOVERY SUBSYSTEM

### 7.1 GENERAL DESCRIPTION

The SRB is designed to separate from the ET after burnout of the SRMs, parachute to the ocean for recovery, allow towing to a refurbishment facility, and subsequently be reused. The recovery subsystem includes those assemblies that are required to separate, deploy, disconnect, float, and retrieve all recoverable system components. The recovery subsystem consists of decelerator components, ordnance devices, time delay and sequencing devices, flotation gear, and retrieval gear.

The decelerator components of the recovery subsystem function to provide attitude and terminal velocity control of the SRBs after separation and until water impact. The decelerator components are located in the nose cap and frustum of each SRB and consist of the pilot parachute, the drogue parachute, and three main parachutes. (Figures 7-12, 7-14 and 7-20, respectively.)

Several significant events take place during the recovery sequence: 1) Separation and Recovery initialization, 2) Nose Cap Jettison 3) Pilot and Drogue Parachute deployment, 3) Frustum Separation, 4) Main Parachute deployment, 5) Nozzle Extension severance/jettison, 6) Water impact, 7) SRB and Parachute Retrieval. See Figure 7-1 for the recovery and parachute deployment sequence.

The recovery sequence begins with SRB separation. After approximately four minutes of freefall, this is followed by nose cap deployment. The nose cap in turn deploys the pilot parachute. The pilot parachute provides the force to pull the lanyard activating the cut knives that cut the loop securing the drogue retention straps. This allows the pilot parachute to pull the drogue pack into the free air stream. The pilot parachute continues to separate the drogue pack from the SRB, causing the drogue suspension lines to deploy from their stowed position.

At full line extension, the drogue deployment bag is stripped away from the canopy and the drogue inflates to its initial reefed condition. The drogue parachute disreefs twice after specific time delays. The primary function of the drogue parachute is to reorient the SRB into a nozzle first reentry for main parachute deployment. It also provides initial SRB deceleration from 540 ft./sec. to 358 ft./sec and suitable dynamic pressures levels for main parachute deployment. After frustum separation, the drogue parachute provides the force to separate the frustum from the SRB forward skirt and to deploy the main parachutes that are mounted in the frustum. The secondary function of the drogue parachute is to slow the descent of the frustum. The drogue parachute remains attached to the frustum and both are later retrieved.

When the Frustum is released, the three main parachutes are deployed. The primary function of the main parachutes is to provide final deceleration of the SRB in a nozzle first attitude. The main parachutes disreef twice after specific time delays and continue to slow the SRB descent to 76 ft./sec. at water impact. Deployment of the three main parachutes prior to water impact is necessary to reach the terminal velocity required for SRB retrieval and refurbishment. The Frustum continues to descend via the drogue parachute, impacting the water at 60 ft./sec.

The retrieval process begins once the SRBs and frustums splash down in the ocean and become available for retrieval operations. The parachutes from each booster are reeled onto one of the retrieval ships. Each frustum is also loaded onto a ship. Each ship tows an SRB back to the refurbishment facility.

## 7.2 RECOVERY SUBSYSTEM OPERATIONAL SEQUENCE

### 7.2.1 Separation and Recovery Initialization

The recovery subsystem operational sequence is initiated at SRB separation by commands from the GN&C computers. These are the same commands as the separation subsystem "B" fire commands to initiate the SRB/ET separation, and are routed to the recovery subsystem logic modules located in the forward IEA of each SRB. The recovery sequence is programmed by combinations of solid-state switches, the latching up of solid-state switches, two time delay devices, and the altitude switch assembly (Figure 7-2), all functioning in conjunction with the two recovery logic modules in each SRB.

Each Separation System (A and B) has separate SRB separation Fire 1 and Fire 2 commands. These 28-volt command signals are hardwired from the Orbiter. All four commands are routed to the SRB recovery subsystem. Fire 1 commands from separation A and B, are OR'ed together. Thus, either command will set the latch that connects the recovery battery (+XD20) to the +XD21 bus. The latch will remain set until the recovery subsystem has been reset or until power has been removed. The +XD21 bus starts a 1Hz clock that is used for timing the various events in the recovery sequence. Fire 2 commands, from separation system A and B, are OR'ed together. The OR'ed output sets a latch that enables the Fire 2 initiated clock pulses. The pulses are derived from the 1 Hz clock started by +XD21 bus. This completes the initialization of the recovery subsystem. Note that both Fire 1 and Fire 2 commands must be received, from the separation system, to initialize the recovery subsystem. Fire 1 alone will not enable the Fire 2 clock pulses; Fire 2 alone will not start the 1 Hz clock.

Once the recovery subsystem has been initialized, the first Fire 2 clock pulse starts a 30-second timer. Apogee occurs at separation +70 seconds. The SRBs have attained an altitude of approximately 230,000 ft. When the 30-second timeout or delay has elapsed, the +XD22 or separation +30-seconds bus, is enabled. There are two separate Recovery Subsystem Arm buses. The +XD22 bus enables a latch and arms the: (1) Nose Cap Release PIC, (2) Main Parachute Deploy/Frustum Release PIC. The other Recovery Subsystem Arm bus, which is a parallel leg, arms the Nozzle Severance PIC.

At SRB separation + 30 seconds, all PICs are armed. The altitude switches are enabled but both switches are open at apogee (230,000 ft.). Figure 7-3 is a sketch of the altitude sensing system. Note the pressure port tubes from the ASA that are routed along the MPSS upper surfaces and connect to ports in the Frustum.

### 7.2.2 Nose Cap Jettison.

At approximately 220 seconds after SRB separation and approximately 140 miles down range, the separated SRB will be in its ballistic descent trajectory. When the SRB descends to approximately 15,700 feet, the high altitude switch closes. The high-altitude switch closure issues the NOSE CAP PICFIRE command. The PIC fires the nose cap NSD and propagates this energy through a confined detonating fuse (CDF) manifold and three CDF assemblies to three pressure cartridges which, in turn, function the three thrusters located on the top ring of the frustum. These three thrusters function and eject the nose cap at nominal 95 feet per second forward and away from the SRB. Figure 7-4 depicts these thrusters and their locations.

When fired, each of the three thrusters, located 120° apart on the top ring of the frustum, produces 30,000 pounds of thrust over a six-inch stroke. At the completion of this stroke, the thruster piston rods

separate from the thrusters and are ejected with the nose cap away from the SRB. All combustion products are confined inside the thrusters and the nose cap ejection deploys the pilot parachute.

The nose cap PIC fire command is initiated directly by the Altitude Switch Assembly when high altitude is detected (not latched by recovery logic circuitry). Premature nose cap release is avoided by powering the ASA when it is at a very high altitude (154,000 feet) before the recovery PICs are armed avoiding any transient output from the ASA due to initial power up.

Figure 7-5 shows nose cap separation and pilot parachute deployment.

### 7.2.3 Pilot Parachute Deployment.

Jettison of the nose cap deploys the pilot parachute. The pilot parachute deployment bag is attached to the nose cap by a three-legged energy modulator/bridle approximately 23 feet long. As the nose cap moves along its jettison trajectory, the pilot parachute retention ties are broken and the pilot parachute canopy is extracted from the deployment bag and deploys.

### 7.2.4 Drogue Parachute Deployment.

The drogue parachute is deployed by the pilot parachute. When the nose cap extracts the pilot parachute pack assembly, a lanyard from the pilot parachute pack activates cut knives that release the drogue retention straps that secure the drogue to the top of the frustum. The pilot parachute canopy suspension lines are attached to the bag bridles on top of the drogue parachute bag. The pilot parachute pulls the drogue pack away from the SRB until the drogue parachute canopy is extracted from the deployment bag.

The drogue parachute is designed with two-stage reefing to minimize peak opening loads experienced during inflation, thereby reducing loads to the parachute and SRB structure. The parachute is reefed by using two reefing lines that constrict the canopy mouth. At predetermined times, the reefing lines are severed by reefing, line cutters. The reefing line cutters are lanyard-actuated devices incorporating a pyrotechnic time delay (see Figures 7-6 and 7-7 for the reefing line cutters). The drogue parachute initially deploys to 60 percent of the fully open drag area. At the end of the first stage time of seven seconds, the first stage cutters sever the first stage reefing line to allow the parachute to deploy to 80 percent of the fully open drag area. At twelve seconds, the second stage cutters sever the second stage reefing line allowing the parachute to deploy to 100 percent. To provide redundancy, two reefing line cutters are used on each reefing line.

### 7.2.5 Frustum Separation

The frustum separation assembly consists of one NSI, one CDF assembly, and one LSC assembly (see Figure 7-8 for the frustum separation assembly).

At 6,000 feet, the low-altitude switch closure will latch up a third latching switch on the recovery logic "I" card in the forward IEA. At 5,500 feet, the ASA low-altitude switch closes. This event sets the main-parachute-deploy latch, which fires the Main-Parachute-Deploy/Frustum Release PIC and starts a 20-second timer for nozzle extension jettison. The PIC initiates an NSD located in the top ring of the forward skirt. The output of the detonator is propagated through the CDF assembly, which detonates the LSC in the detonator block assembly. The detonator block assembly detonates the LSC in the frustum assembly. This LSC severs the structural ring holding the frustum to the forward skirt and allows the drogue parachute to pull the frustum away from the SRB.



Pull-away connectors for cables crossing the SRB forward skirt into the frustum are provided for cable separation during recovery. Pull-away connectors are included for the altitude switch signals, one each for the drogue deployment NSD, the BSM A NSD, and the BSM B NSD.

#### 7.2.6 Main Parachute Deployment

At frustum separation, the drogue parachute pulls the frustum with the main parachute support structure and main parachute packs away from the SRB. As a result, break-ties on the riser lines release the deployment bag mouth closures, opening the bags. The three main parachutes are deployed out of the base of the frustum as it continues to be separated from the SRB by the drogue parachute.

Each main parachute employs a two-staged inflation sequence similar to that described for the drogue parachute. The main parachute initially deploys to 20 percent of the fully open drag area. At the end of the first stage time of ten seconds, the first stage cutters sever the first stage reefing line to allow the parachute to deploy to 40 percent of the fully open drag area. At seventeen seconds, the second stage cutters sever the second stage reefing line allowing the parachute to deploy to 100 percent. To provide redundancy, two reefing line cutters are used on each reefing line. (Reference Figures 7-6 and 7-7.)

#### 7.2.7 Nozzle Extension Jettison

At approximately 1,100 feet, the previously set 20-second delay timer sends a signal to fire the NEJ PIC. This activates the linear shaped charge on the RSRM nozzle, jettisoning the nozzle extension. The nozzle extension must be jettisoned in order to prevent damage to the TVC hardware, located inside the Aft Skirt, due to water impact forces.

Timing of the SRB nozzle extension jettison is chosen to (a) prevent detonation of the TVC system hydrazine fuel during reentry, (b) to minimize heat and flame damage to the AFT skirt heat shield curtain caused by the Booster exhaust gas detonation after separation, and (c) to prevent contact between the SRB and the severed nozzle extension at water impact. Reference Figure 7-9, SRM Nozzle Linear Shaped Charge Cutoff Device.

#### 7.2.8 SRB Water Impact

The main parachutes slow the SRB to 76 ft./sec at water impact. After impact, the SRB will shift to a horizontal, or "log mode", until the water and air stabilize within the empty motor case and it comes to rest in a vertical, or "spar mode", with the Forward Skirt out of the water. The SRB in post-splashdown spar mode is shown in Figure 7-10.

After water impact, the main parachute dispersion bridles are separated from the risers via the seawater activated releases (SWAR). The SWARs are self-contained, requiring no electrical input from the SRB recovery subsystem electronics. The main parachutes remain attached to the booster via the Main Parachute Retrieval Lines.

The frustum, decelerated by the drogue parachute, impacts the water at 60 ft./sec. The frustum floats apex down with the drogue parachute attached and submerged as shown in Figure 7-11. The frustum is made self-buoyant by the addition of flotation material. Foam is located between internal rings and is contoured to the inner mold line of the frustum. The location of the foam will normally float the base of the frustum out of the water. The frustum is a recoverable structure.

The pilot parachute remains attached to the drogue bag, which contains flotation. The pilot parachute and the drogue bag are recovered if located.

The 315-pound nose cap and pilot parachute deployment bag free-fall to the ocean and are not recovered. Figure 7.5 illustrates the nose cap separation.

### 7.3 RECOVERY SUBSYSTEM COMPONENTS

The recovery subsystem includes elements of several SRB subsystems and components. Table 7-1 lists these components and categorizes them as to the appropriate subsystem.

**TABLE 7-1 Recovery Subsystem Functional Components**

ITEM	SUBSYSTEM
Nozzle Jettison LSC	SRM
Nose Cap Thrusters, Frustum Separation LSC, CDF Assemblies and Manifolds, NSDs	Pyrotechnic
Recovery Logic Modules	E&I
Altitude Switch Assembly	E&I
Parachutes (Mains, Drogue, Pilot)	Decelerator
Main Parachute Support Structure	Decelerator
Nose Cap	Structures
Frustum (including flotation)	Structures
SWAR	Decelerator
Reefing Line Cutters	Pyrotechnic
Pressure Port Tubes	Decelerator

#### 7.3.1 Pilot Parachute Pack Assembly

The Pilot Parachute pack assembly includes the pilot parachute canopy assembly with suspension lines, a deployment bag, a nose cap bridle and an energy absorber. The pilot parachute is an 11.5 ft. diameter, 20-degree conical ribbon parachute with a 16% uniform porosity distribution. An over-inflation line restricts the open diameter to 10 feet during deployment. The weight of the Pilot Parachute Pack Assembly is approximately 55 lbs. Reference Figure 7-12 for the Pilot Canopy Assembly and 7-13 for the Pilot Pack Assembly.

#### 7.3.2 Drogue Parachute Pack Assembly

The Drogue Parachute Pack Assembly major components include a deployment bag, deployment bag hardcover and flotation, retrieval line, noodle float, retrieval line chute, drogue parachute canopy, suspension lines, attachment hardware, and two reefing lines each with redundant reefing line cutters (ref Figures 7-6 and 7-7). The drogue parachute is a 54 ft. diameter, 20-degree conical ribbon parachute with a 16% uniform porosity distribution. The weight of the Drogue Parachute Pack Assembly is approximately 1100 lbs. Reference Figures 7-14 and 7-15 for the Drogue Canopy Assembly and Figure 7-16 for the Drogue Pack Assembly.

#### 7.3.3 Drogue-Pilot Assembly

The Drogue-Pilot Assembly consists of the Pilot Parachute Pack Assembly, Drogue Parachute Pack Assembly, retention straps, retention loop, cut knife assembly and knife boot. The Drogue-Pilot Assembly is retained by six retention straps held at the top of the drogue parachute by a cut loop and

bound down by six ratchet spools on the forward support ring of the frustum. Reference Figures 7-17, 7-18, and 7-19.

#### 7.3.4 Main Parachute Pack Assembly.

Each Main Parachute Pack Assembly. consists of the main parachute, a deployment bag, suspension lines, dispersion bridles, SWARs, riser lines, attachment hardware, and two reefing lines with redundant reefing line cutters (ref Figures 7-6 and 7-7). The main parachute is a 136 ft. diameter, 20-degree conical ribbon parachute with a 15.4% uniform porosity distribution. The weight of each Main Parachute Pack Assembly is approximately 2200 lbs. Reference Figures 7-20, 7-21, and 7-22.

#### 7.3.5 Main Parachute Cluster Assembly

The Main Parachute Cluster Assembly consists of a cluster of three Main Parachute Pack Assemblies, the Main Parachute Support Structure (MPSS), and parachute retention components. Reference Figure 7-23 for the Main Parachute Support Structure.

The three main parachutes are packed in deployment bags that are housed in individual compartments formed by the MPSS within the frustum. Figure 7-24 shows the main parachutes installed in the main parachute support structure prior to installation in the frustum. Even though it is mechanically attached to the frustum, the MPSS is not considered a portion of the frustum structural assembly. It was designed to maintain separation of the main parachutes during installation and deployment.

#### 7.3.6 Recovery Electronics and Instrumentation.

See Section 4.0.

### 7.4 At-Sea Retrieval Operations

The retrieval process begins once the SRBs splash down in the ocean and become available for retrieval operations. Each ship is capable of retrieving either booster. However, due to considerations for “Hip-Tow”, the left hand SRB and associated components are typically retrieved by the MS Freedom Star. The MS Liberty Star is typically assigned to retrieve the right hand SRB and its associated components. Figure 7-26 shows a retrieval ship, which is 176 ft. long at the water line and 37 ft. abeam.

The main parachutes remain attached to the booster via the Main Parachute Retrieval Line until the Retrieval Operations crew arrives at the booster in the ambar dive boat. Figures 7-26 and 7-27 show the recovery ship and dive ambars used in ocean operations. Figure 7-28 shows the dive operations scale of SRBs to divers. The parachutes are then cut loose from the booster and floats are attached pending reel-in on the ships. The risers remain attached to the SRB, one of which is used for SRB towback (see Figure 7-25). The three main parachutes from each booster are reeled onto their respective retrieval ships. Following main parachute retrieval, the drogue parachute is reeled aboard the ship, with its riser lines still attached to the frustum. Using the drogue riser lines, the ship-board crane hoists the frustum onto the rear deck platform.

After splashdown, the SRB floats upright in “spar mode” due to partial filling of water (Figure 7-10). For towback, the SRB must be re-positioned into a horizontal or “log mode” as shown in Figures 7-29

and 7-30. To achieve this, retrieval divers deploy the Enhanced Diver Operated Plug (EDOP). The EDOP (see Figure 7-31) is inserted into the RSRM nozzle and air is pumped into the motor case in order to displace the seawater. This process allows the SRB to rotate to the “log mode” for tow back to Port Canaveral. Once the ships reach the port, the boosters are repositioned alongside the retrieval ships for navigation through the port and locks into the Banana River. “Hipping the Tow” in this manner provides closer control of the SRBs through the calmer inland waters. Because of various features on the exterior of the SRB, including the ET struts and connections, the right hand SRB must be hipped to the starboard side (right) of the towing ship. Conversely, the left hand SRB must be hipped on the port side (left) of the towing ship. This explains why the MS Liberty Star, which is typically prepared to hip on the right, will tow the right hand SRB, and why the MS Freedom star will typically tow the left. In order for the ships to swap towing responsibilities, procedures for onboard activities must be reversed to accommodate the mirrored SRB. Figure 7-33 shows the “hip tow” configuration before the ships reach the slip at Hangar AF.

Once at the slip at Hangar AF, the SRBs are lifted by crane and transported to the hangar facility. This process is shown in four steps in Figure 7-34.

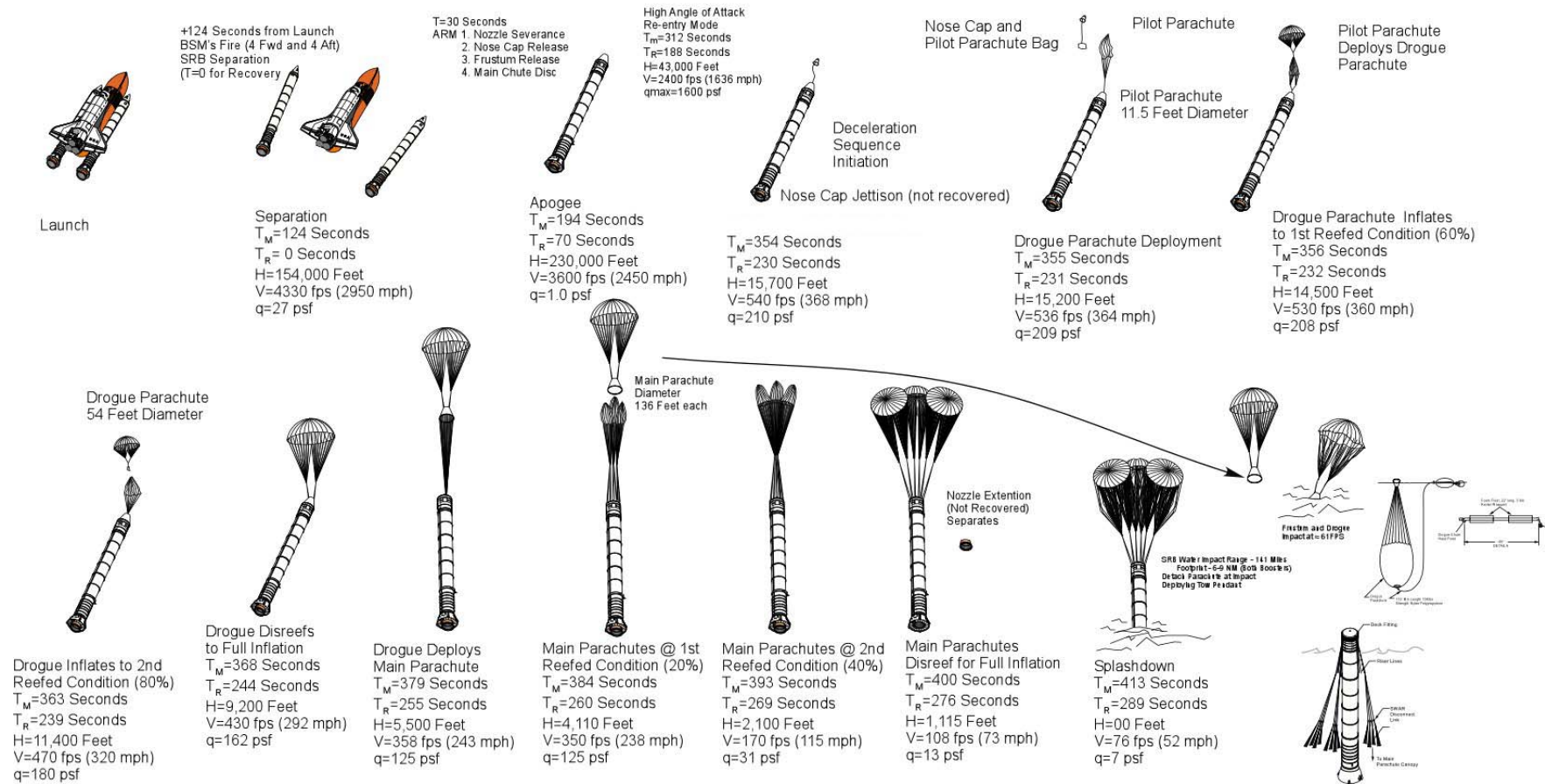

Figure 7-1. SRB Operational Profile launch to splashdown

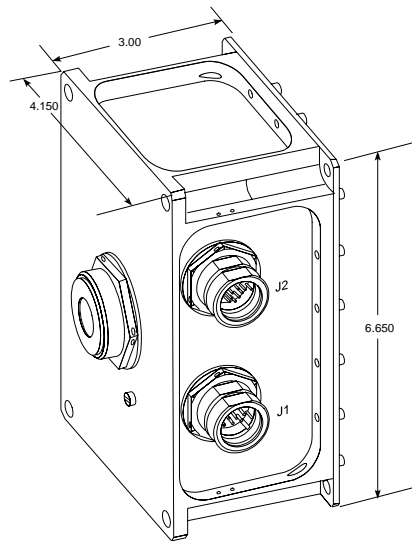

Figure 7-2. Altitude Switch Assembly

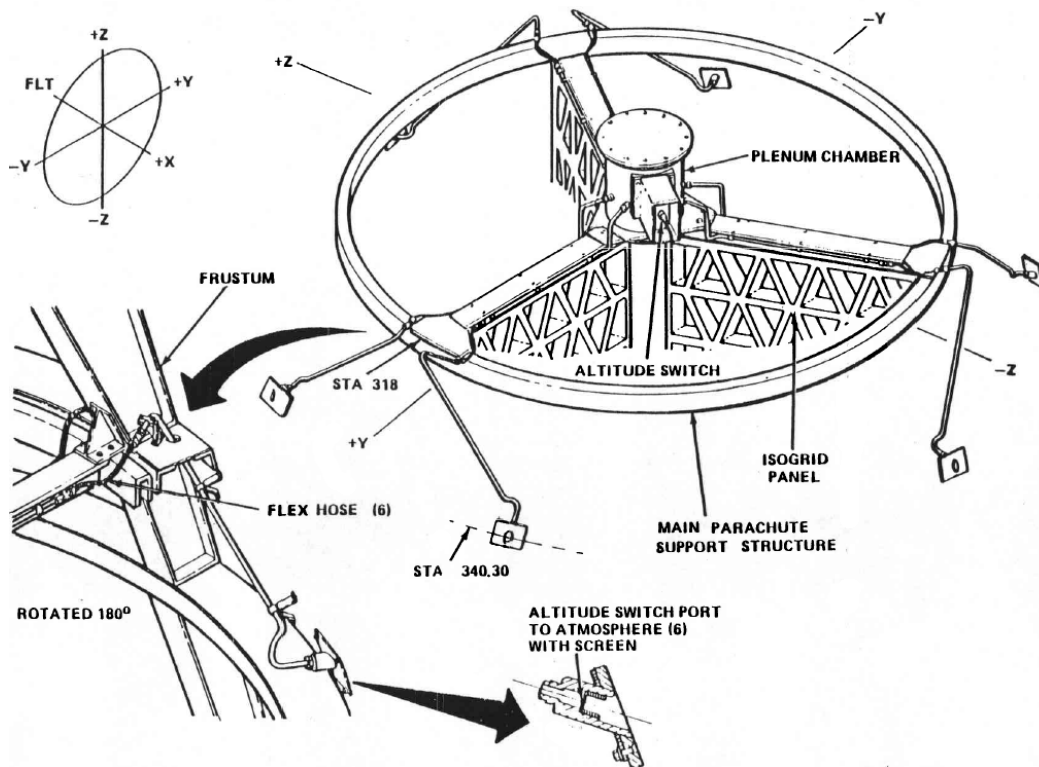

Figure 7-3. SRB Altitude Sensing Subsystem & Forward Main Parachute Support Structure

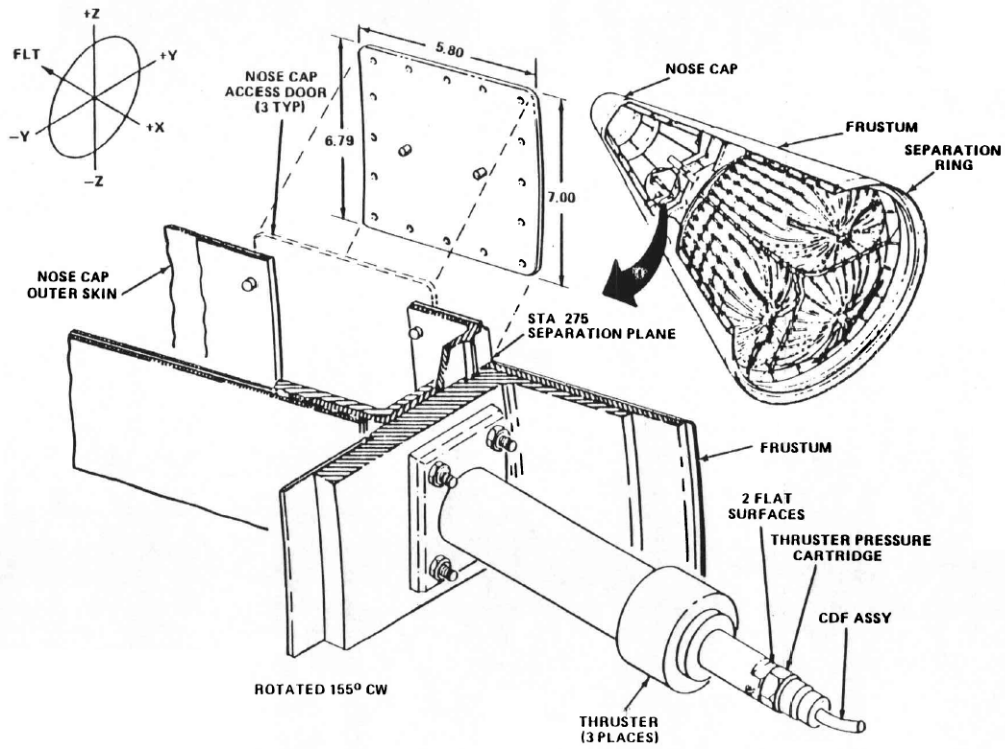

Figure 7-4. SRB Nose Cap Thruster-Installation

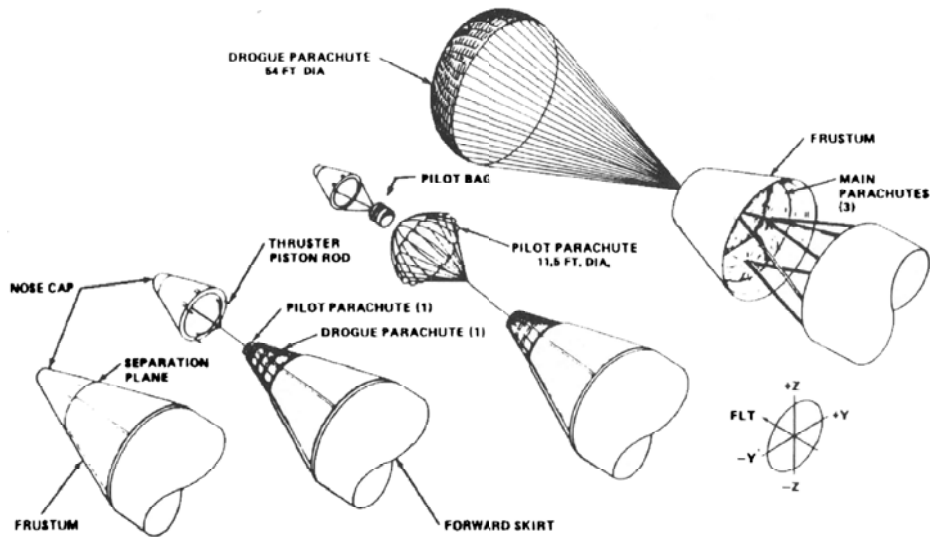

Figure 7-5. SRB Nose Cap Separation & Pilot Parachute Deployment

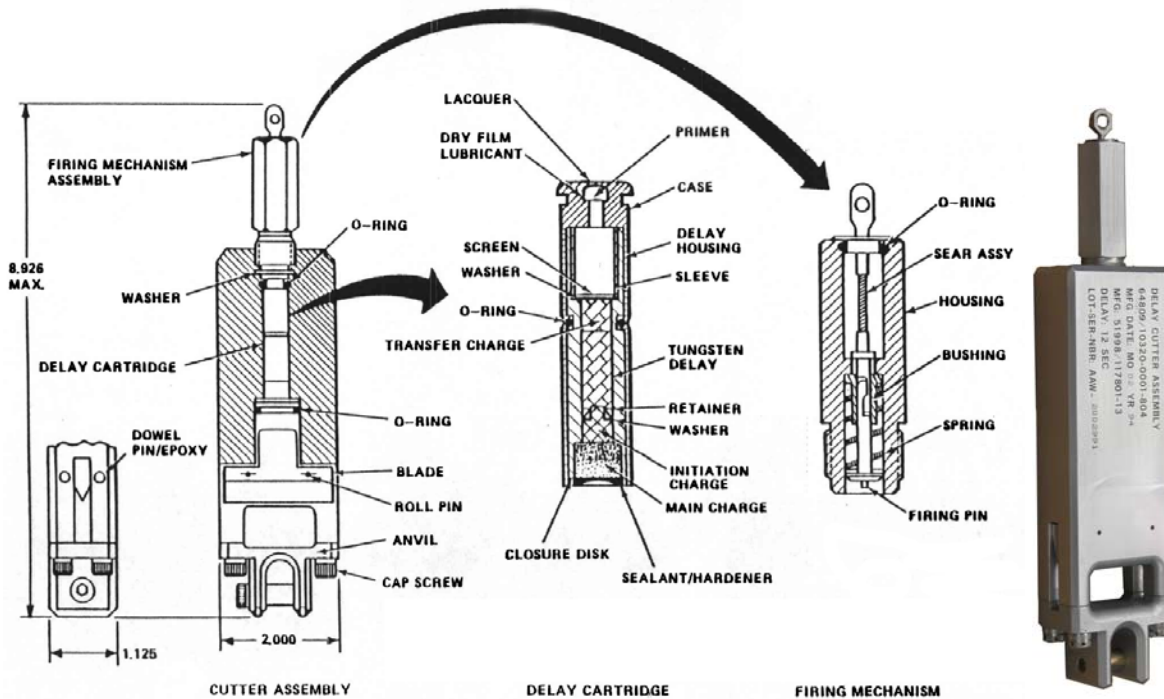

Figure 7-6. Reefing Line Cutter

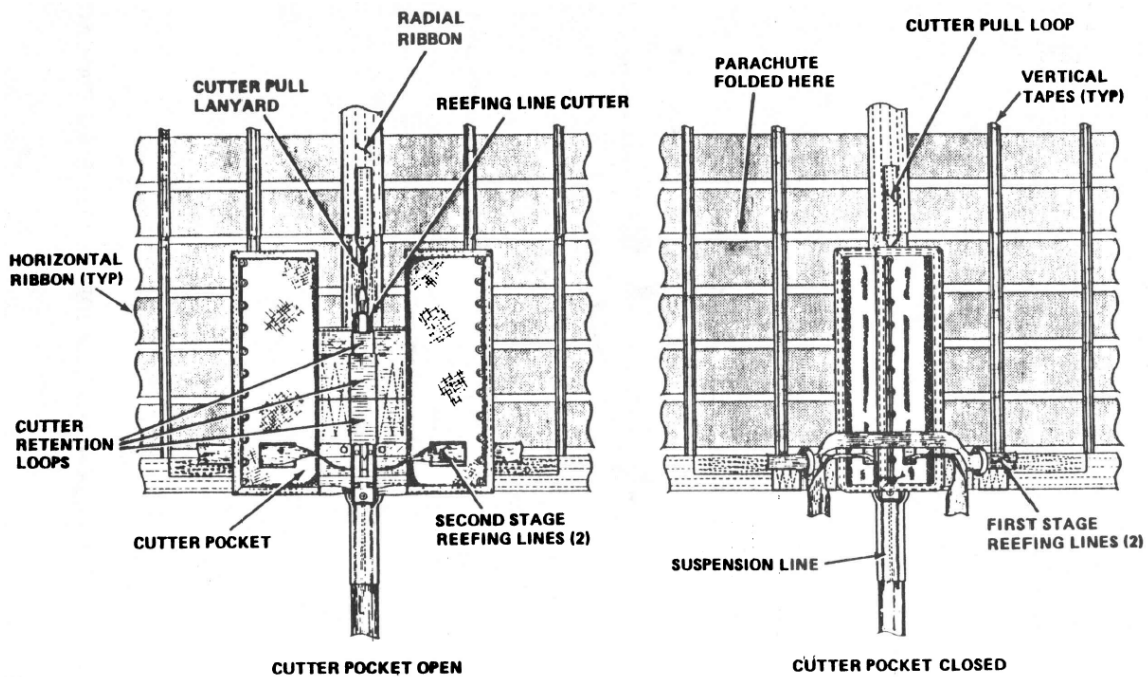

Figure 7-7. Second Stage Reefing Line Cutter On Parachute



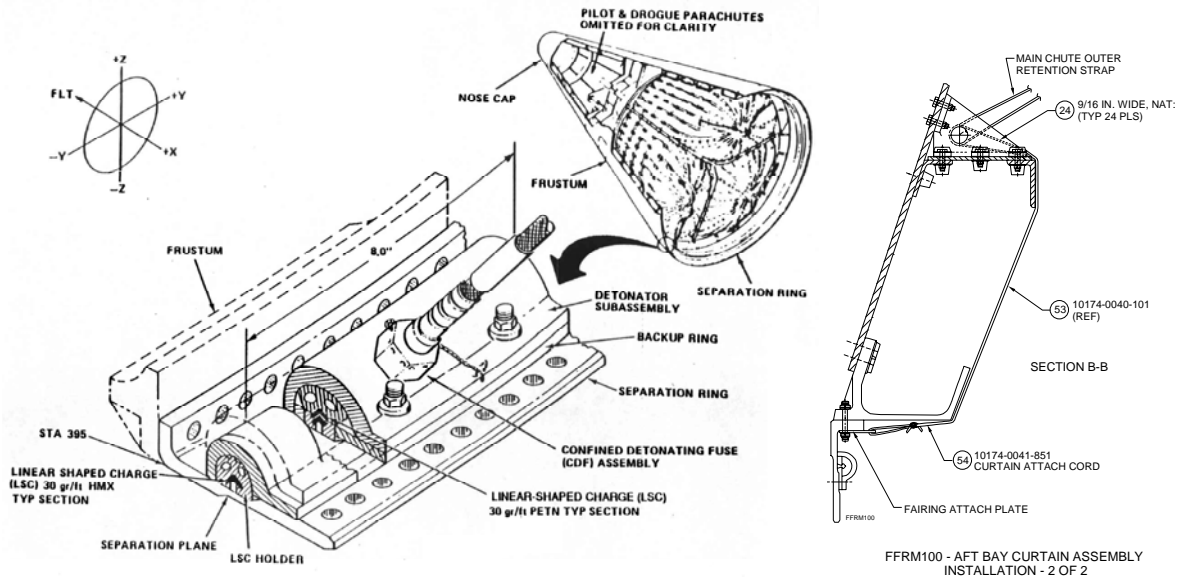

Figure 7-8. SRB Frustum/Separation Ring Assembly

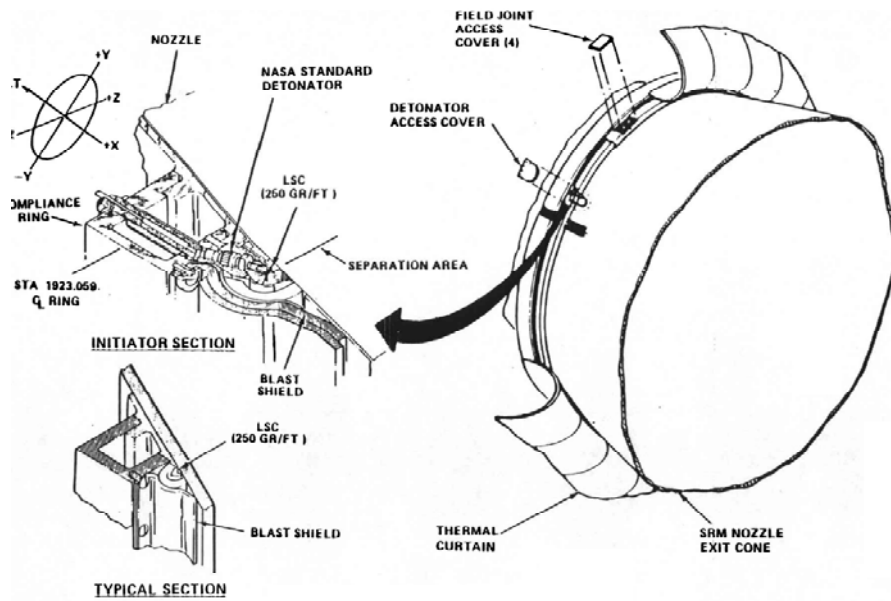

Figure 7-9. SRM Nozzle Linear Shaped Charge Cutoff Device



Figure 7-10. SRB Post-Splashdown Spar Mode

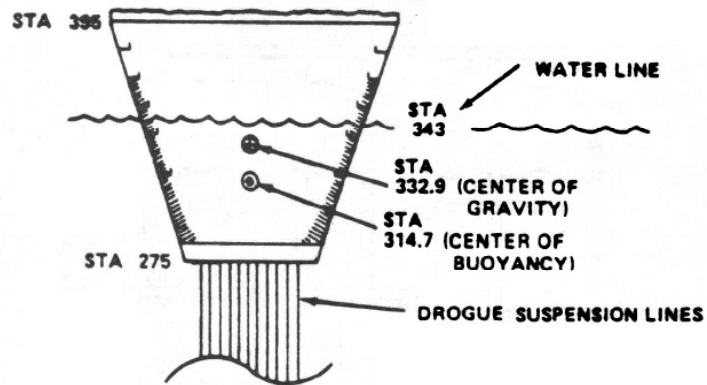

Figure 7-11. SRB Frustum Flotation Model With Drogue Attached

# PILOT PARACHUTE

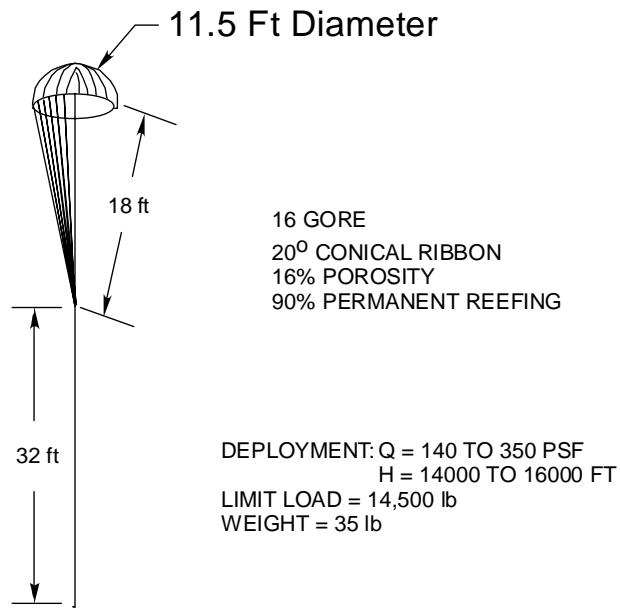

Figure 7-12. Pilot Parachute Canopy Assembly



Figure 7-13. Pilot Parachute Pack Assembly

# DROGUE PARACHUTE

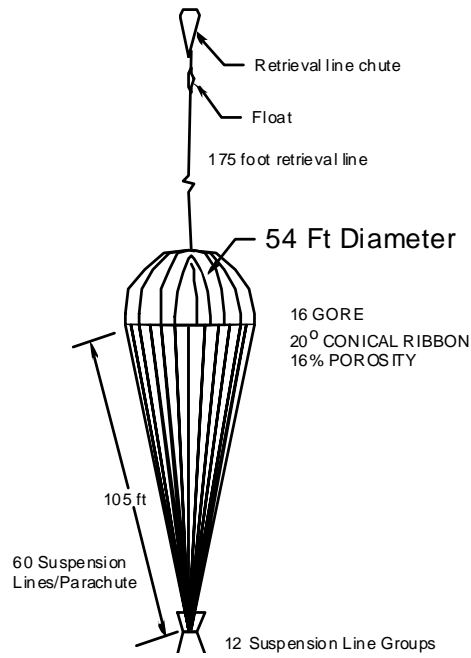

Figure 7-14. Drogue Parachute Details

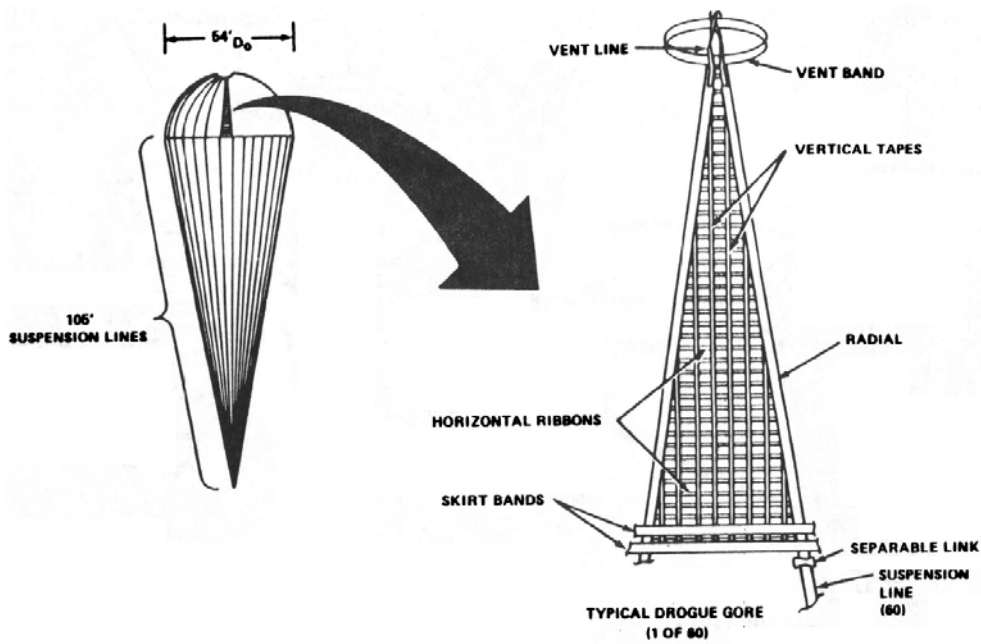

Figure 7-15. SRB Drogue Parachute Gore Configuration



Figure 7-16. Drogue Parachute Pack Assembly



Figure 7-17. Pilot Pack connected to Drogue Parachute Pack

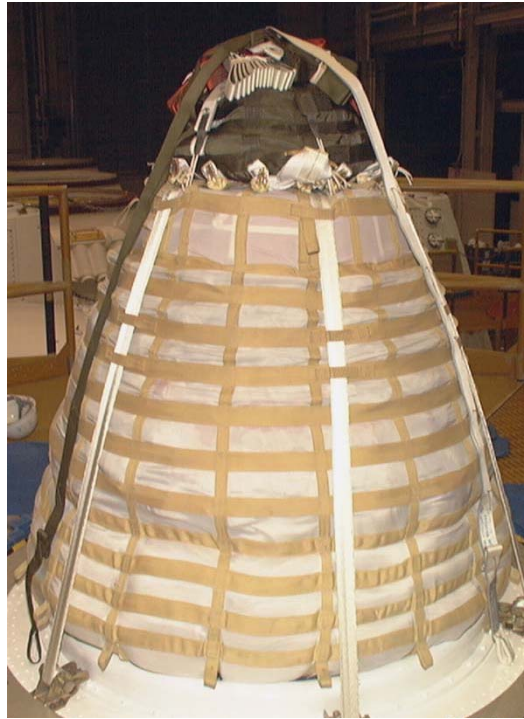

Figure 7-18. Drogue-Pilot Assembly

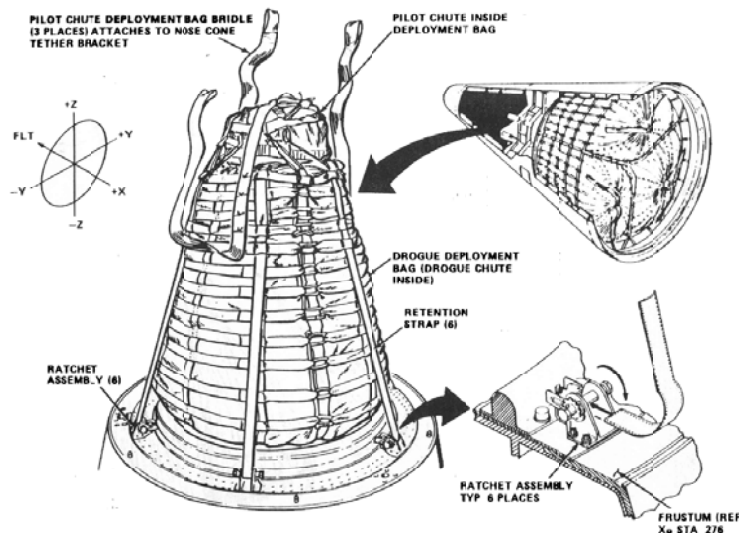

Figure 7-19. Drogue-Pilot Assembly Integration

# MAIN PARACHUTE

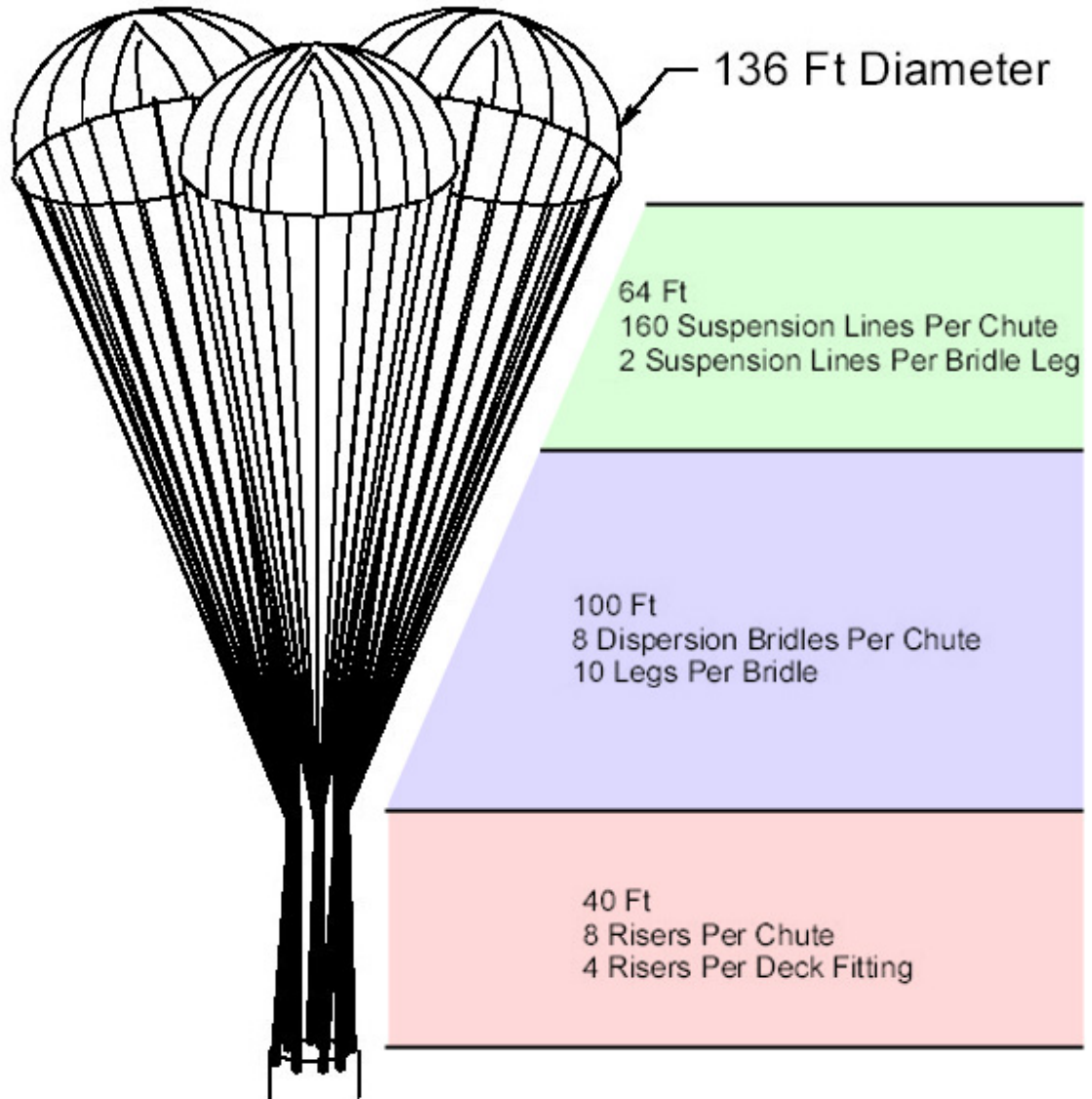

Figure 7-20. Main Parachutes Deployed

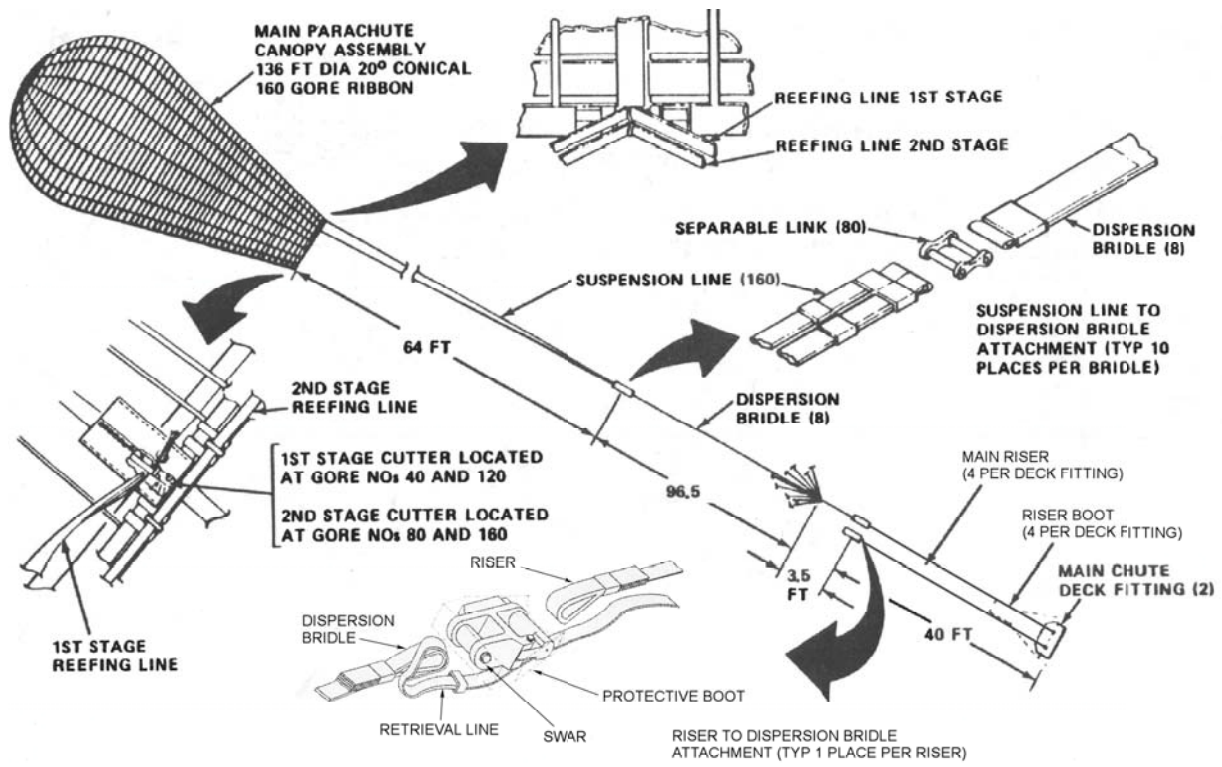

Figure 7-21a. Main Parachute Details

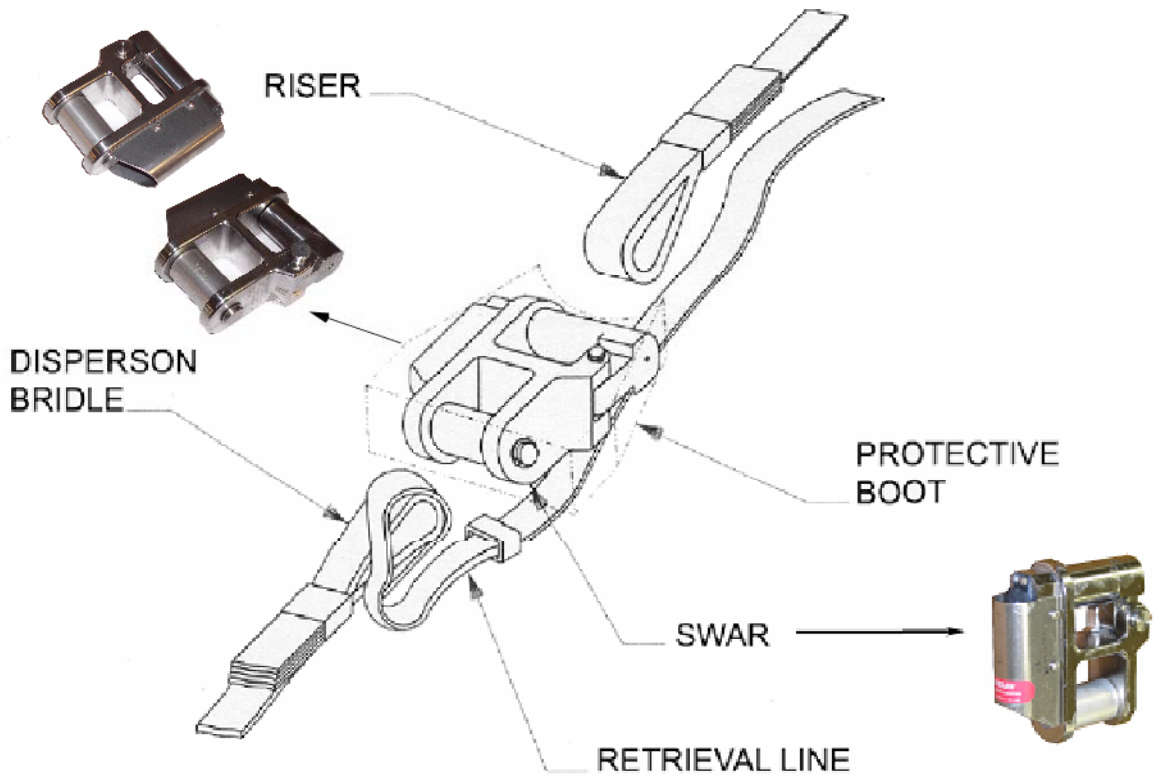

Figure 7-21b. SWAR details





Figure 7-22. Main Parachute Pack Assembly

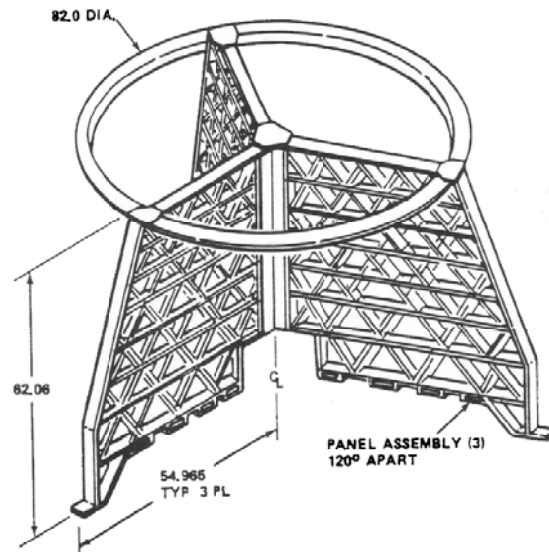

Figure 7-23. Main Parachute Support Structure



Figure 7-24. Main Parachute Cluster Assembly and Plenum Chamber

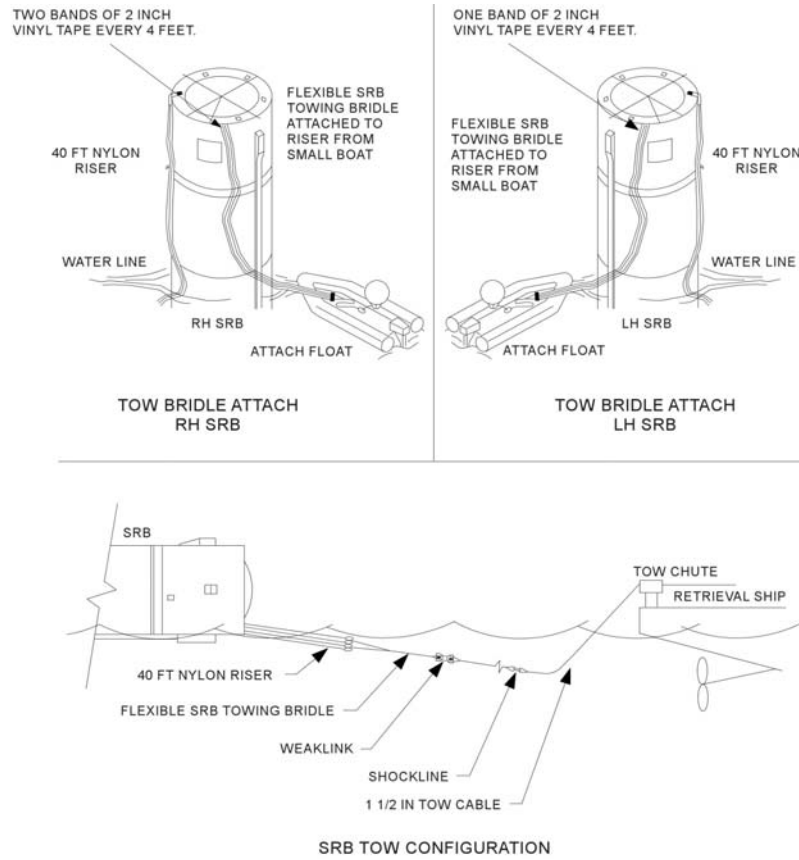

Figure 7-25. Water Impact Conditions And Post Impact Parachute Placement

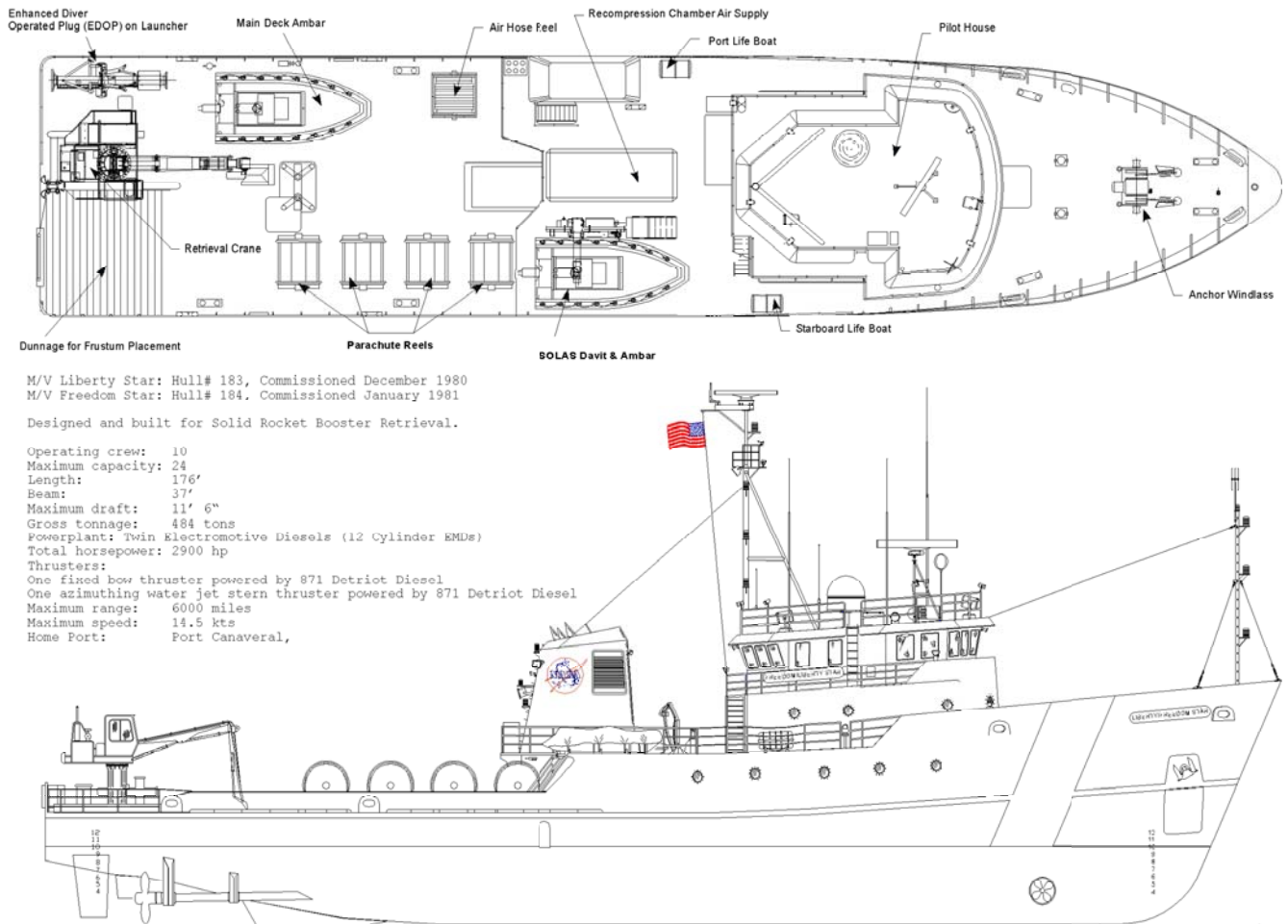
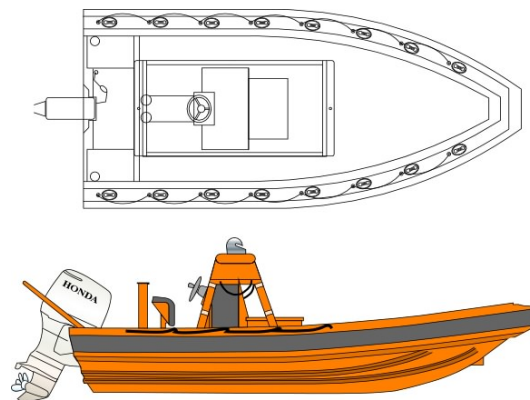

Figure 7-26. SRB Recovery Ship



18' Ambar Dive boat

Figure 7-27. SRB Recovery Ambar

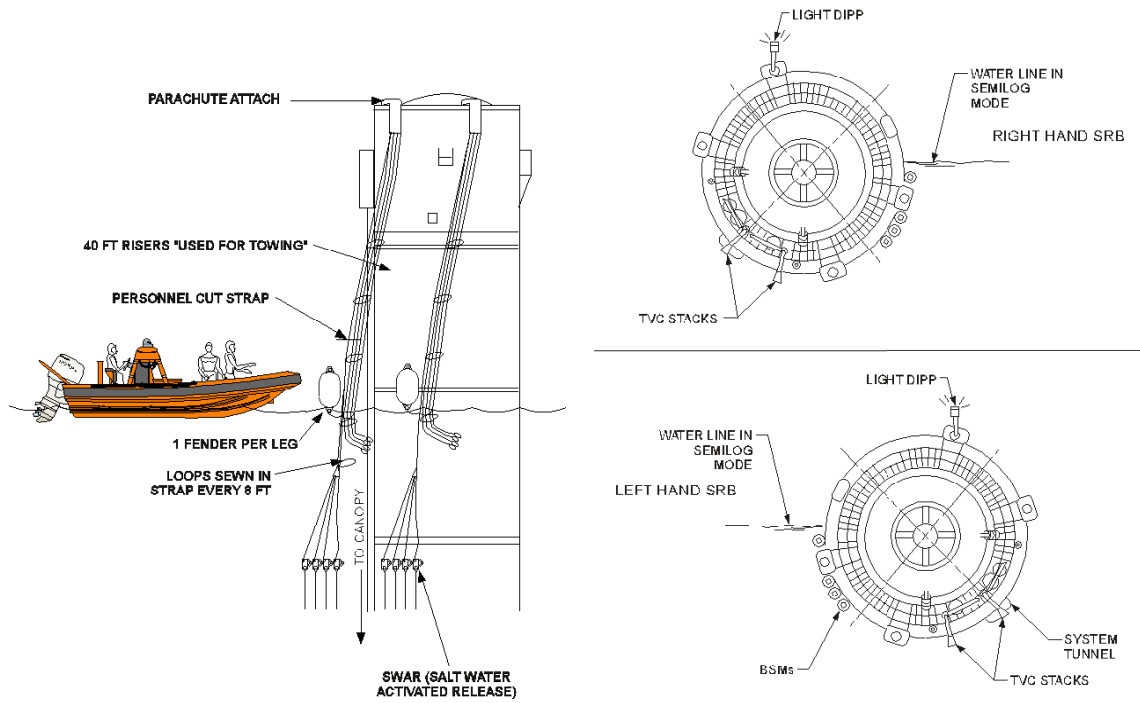

Figure 7-28. SRB Diver Operations

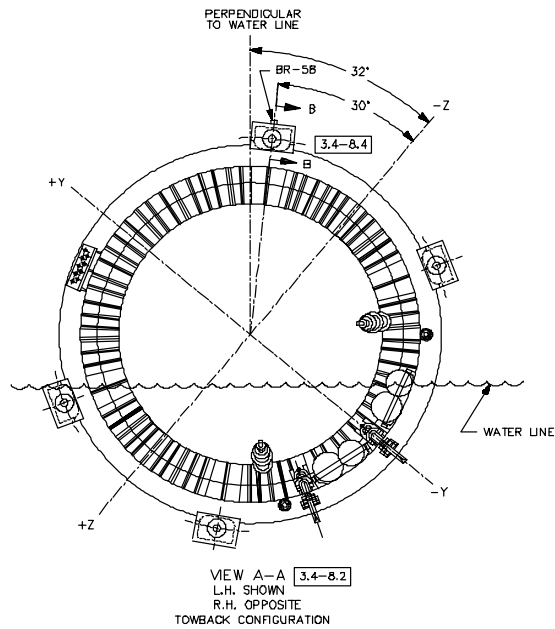

Figure 7-29. SRB Log Mode Orientation and Waterline

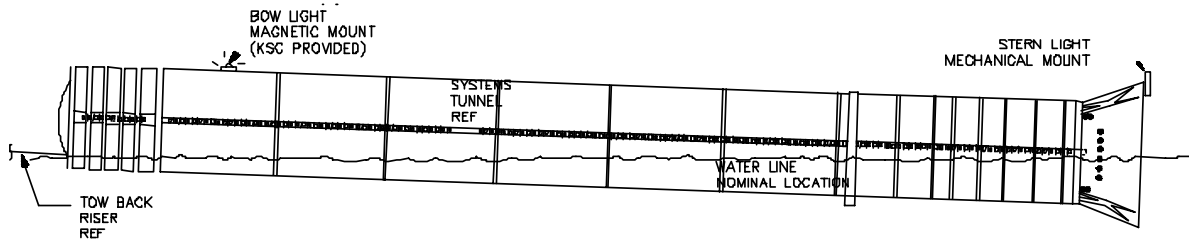

Figure 7-30 SRB in Log Mode Showing Waterline (EDOP not shown)

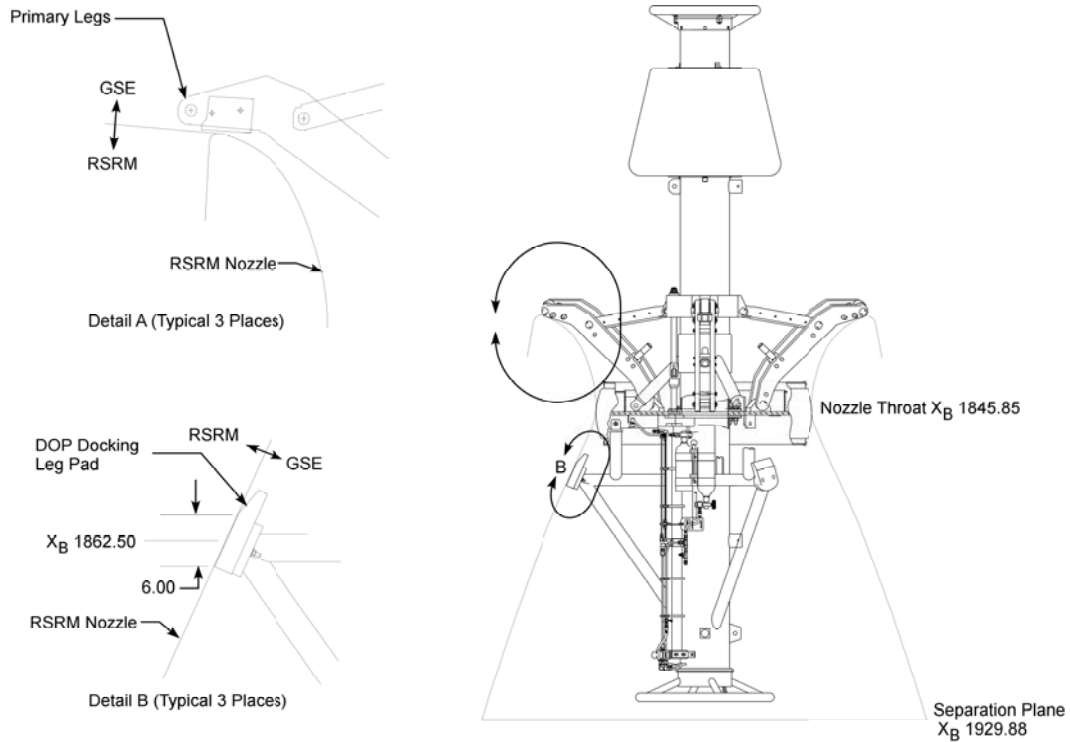

Figure 7-31 Enhanced Diver Operating Plug

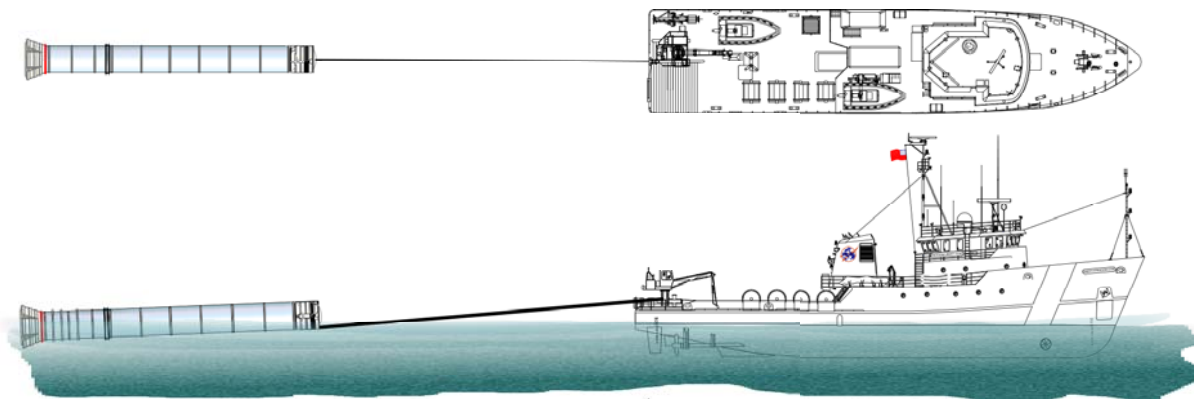

Figure 7-32 SRB in Log Mode Being Towed by Recovery Ship during transit to Slip

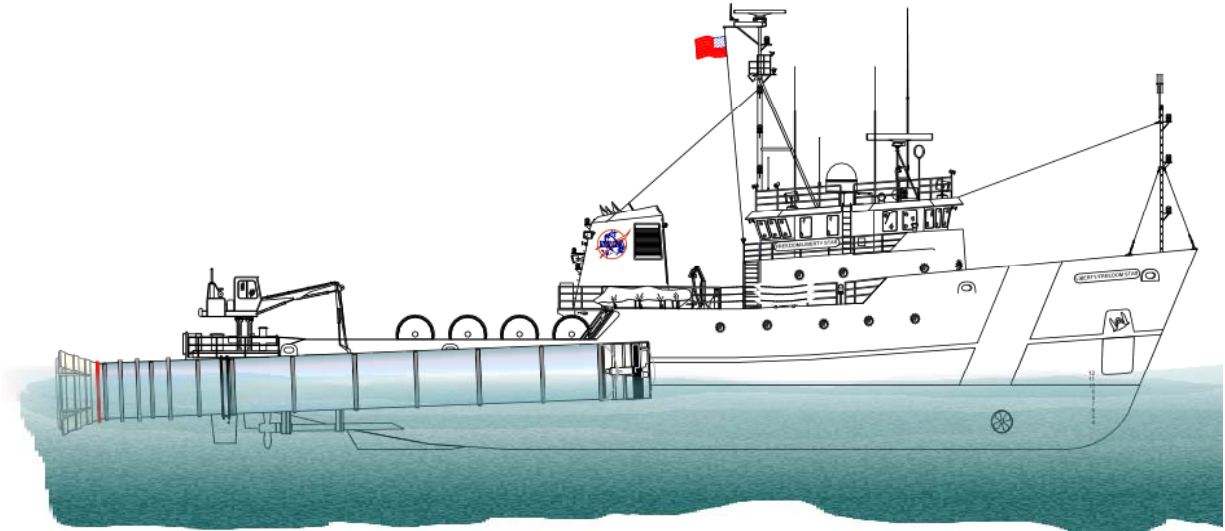

Figure 7-33 SRB and Recovery Ship During Hip Operations

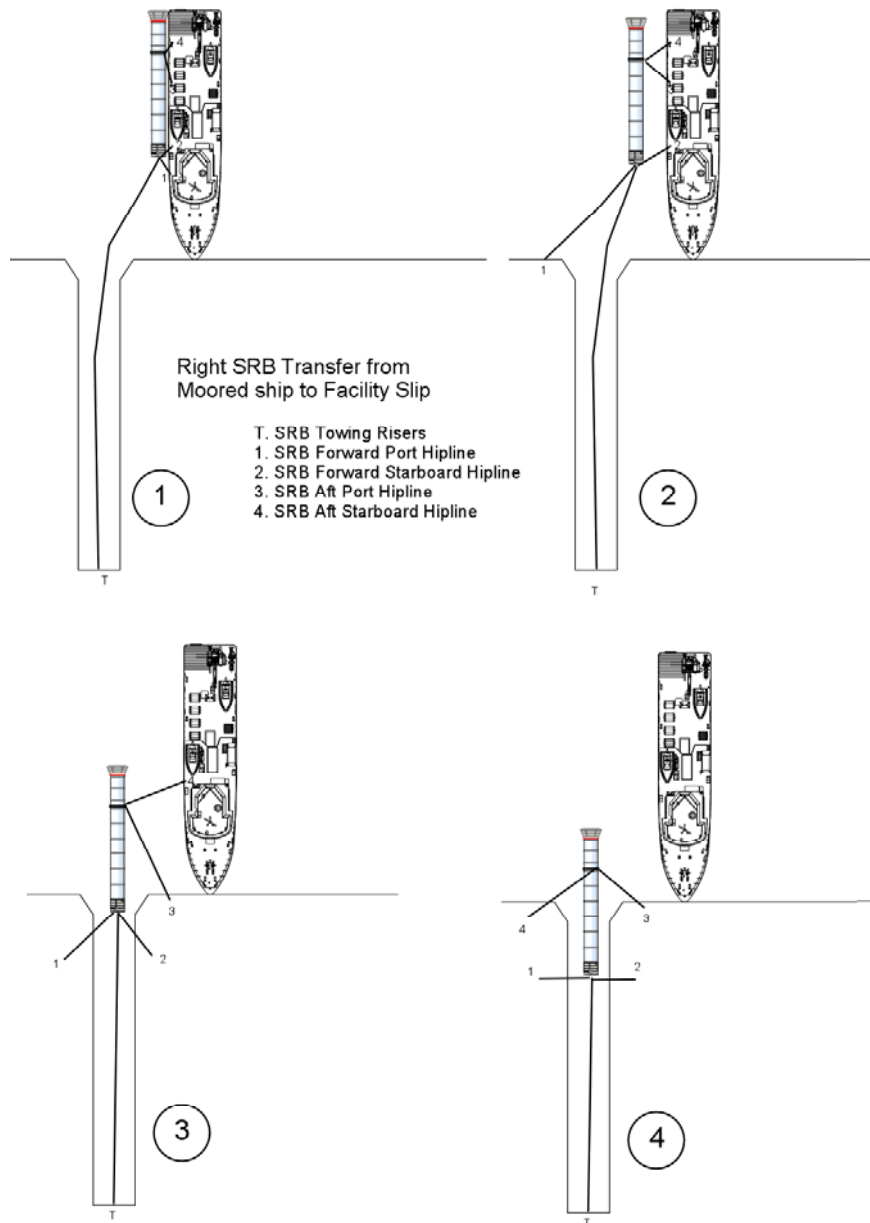

Figure 7-34 SRB Retrieval Operations at SRB Slip.



## 8.0 RANGE SAFETY SUBSYSTEM

### 8.1 GENERAL.

The Range Safety Subsystem (RSS) is designed to cause flight termination of the Space Transportation System (STS) should either a major malfunction or errant path occur during the boost stage of flight. The RSS terminates flight by splitting the cases of the SRBs, which eliminates thrust.

The Flight Control Officer (FCO), through the ground equipment, may be required to transmit range safety commands during an STS launch at any time from lift-off until SRB separation. The SRBTS and the skin-tracking signal returns from the vehicle provide distance and direction information to the range computer. The computer provides the FCO with real-time information on vehicle location, direction, and impact prediction. This data, in addition to visual observations, allows the FCO to evaluate the flight and to decide if flight termination must be considered. If off-nominal conditions occur, the FCO must decide whether to allow continued vehicle flight (if hazards to life and/or property are decreasing) or to immediately initiate flight termination action.

NASA provides the Eastern Test Range (ETR) with a trajectory prediction for each launch. From this idealized trajectory data, the range derives "limit lines" for satisfactory performance. The trajectory and limit lines are displayed for the FCO, and tracking data is displayed as a progression of points within the limit lines. Should the tracking points break the limit lines, the FCO has the option to initiate the destruct sequence. Other considerations, such as voice communication of all systems operating properly, could temper that option judgment. If flight termination action is required, the FCO will issue the destruct commands that are sent to whichever ground site is active. These commands cause the ground station to transmit the ARM and FIRE commands via encoded messages. The first of these commands (ARM) causes the Pyro Initiator Charger (PIC) circuitry to charge to approximately 40 volts DC, provides power to the FIRE latch, and illuminates a cockpit ARM light on the Orbiter display panel. The second command (FIRE) transmitted to the vehicle causes the PIC voltage to discharge into the NSI bridgewire, initiating the ordnance chain. The SRB RSS Functional Diagram is shown in Figure 8-1.

The RSS is a duplex configuration that provides dual subsystems ("A" and "B") on each SRB that are "cross-strapped" to the opposite SRB through the ET. The SRB RSS is comprised of the following items:

- a. Command antennas (2 per SRB).
- b. A directional and a hybrid coupler. (One each per SRB, See Figures 8-2 and 8-3.)
- c. Integrated Receiver Decoder (IRD) (2 per SRB)
- d. Range Safety Distributor (RSD) (Contains redundant and isolated control circuits called Subsystem A and Subsystem B)
- e. Redundant NSIs
- f. An S&A Device
- g. Four CDF assemblies
- h. Two CDF Assembly bulkhead connectors
- i. A destruct assembly - Linear Shaped Charge (LSC) on each SRB
- j. Harness assemblies (all interconnecting cables)
- k. Redundant power from two 50 AH Silver-Zinc Batteries (The SRB RSS Subsystem A is powered by the RSS battery (20 cells) and Subsystem B is powered by the Recovery Battery (19 cells).

## 8.2 RSS CONTROL INTERFACES.

The command system provides remote control of onboard STS flight termination functions. These command control functions can be categorized as (a) launch processing system (LPS) control of pre-launch configuration, test, and initiation functions through data bus or hardwire interfaces and "closed-loop" RF, or (b) in-flight commands initiated through the master events controller (MEC) or through the Air Force ground transmitter "open-loop" RF interfaces.

### 8.2.1 LPS Command Control.

The LPS exercises pre-launch control of onboard RS functions through the T-0 umbilical that connects the GSE to the orbiter. Most LPS commands are transmitted through the umbilical and into the orbiter MEC. These commands are then routed through the SRB to the MDMs in the forward IEA and then on to the individual component subsystem control devices. Using this method, the LPS issues signals to (a) arm the positioning of the RSS S&A devices (Figures 8-4 and 8-5), (b) command power turn "ON/OFF for individual SRB systems, and (c) command exercise of the BITE for the PIC. The LPS also issues the RSS inhibit/reset commands that are propagated by an uninterrupted hardwire connection in the SRB directly to the reset pin on the ARM latching switches in the RSD. Figure 8-6 illustrates the S&A device along with the RSS panel number 1. Figure 8-7 illustrates panel number 2. Panel number 2 contains the redundant RSS integrated receiver/decoder (IRD) (shown schematically in Figure 8-8 and described in Section 8.3).

The LPS also controls the "closed-loop" GSE used to transmit RF ARM/FIRE signals to the onboard RSS for major ground systems tests, e.g., shuttle interface tests; flight readiness firing (FRF), Terminal Count Demonstration Test (S0017), and at T-45 minutes, the final pre-launch "closed-loop" tests.

In every case, the STS telemetry system provides "feedback" data to verify subsystems response to valid commands.

### 8.2.2 In-flight Commands.

At approximately five seconds before SRB separation, the orbiter computer will sense SRB motor chamber pressure decay and will begin the SRB separation sequence. As a part of this sequence, both SRB S&A devices will be commanded (by the MEC) to the SAFED position and SRB RSS power will be commanded OFF.

The Air Force FCO controls in-flight RF commands. Should the FCO determine that the orbiter has violated the safety limit lines/criteria, he will initiate transmission of the ARM/FIRE commands to perform the ordnance detonation. Figure 8-9 shows the RSS ordnance component layout schematically and Figure 8-10 shows the LSC located in the systems tunnel along with a representation of the RSS antenna.

## 8.3 DESTRICT SUBSYSTEM DESCRIPTION.

The physical configuration of the STS demands a complex antenna system design in order to meet the requirements imposed by the ETR in accordance with EWR 127-1. The range requires the antenna system to provide 95 percent spherical coverage. This composite coverage requirement is met by a set of four antennas, with the cross strapping of the direct current (DC) output of the RSD (see Figure 8-11 for RSS antenna locations).

The interrelationship between the left and right SRB RSS is a bidirectional cross-strapped configuration via each SRB RSD. Subsystem A and Subsystem B of each SRB RSD are interconnected to the Subsystems B and A of the other SRB RSD. Any command (ARM or FIRE) received by either Subsystem A or Subsystem B of one SRB RSS is also received by Subsystem B or Subsystem A, respectively, of the other SRB RSS. This interface exists until separation of the SRBs.

The IRD receives the frequency modulated range command message at 416.5 megahertz (MHz) and demodulates the audio message format. The decoder section uses high-speed micro-processing techniques to determine that the received audio message has the same tone pair format as the flight code loaded into memory prior to launch. When the received message contains a tone pair sequence identical to the ARM or FIRE preloaded code, a corresponding output command of 28 volts is issued to the RSD for processing..

The SRB RSD has the following capabilities:

- a. Provide voltage regulation (System A only) and control of power to the RSS.
- b. Provide control of the S&A device (System A only) in response to orbiter or LPS commands.
- c. Accept ARM and FIRE commands from the IRD and initiate destruct action.
- d. Provide isolation and interconnection for cross-strapped ARM and FIRE commands between the SRBs.
- e. Inhibit pyrotechnic initiation during pre-launch operations.
- f. Provide RSS status to telemetry and an RS ARMED indication to alert the crew of an ARM command issued.

The RSD contains the PIC subassemblies that provides for storage of energy in a capacitor bank. This energy is discharged through the NSD when an appropriate command sequence is received from the IRD.

#### 8.3.1 RSS ARM Sequence.

The ARM and FIRE outputs of the RS IRD are connected directly into the RSD. The RSD provides isolation and routing for the cross-strapped ARM and FIRE signals to and from each SRB RSS . Each section of the RSD contains two electronic type latching switches (as differentiated from electromechanical relays). One of these latching switches receives the ARM command pulse from the IRD (or cross-strapping) while the other receives the FIRE command pulse. When the ARM switch is actuated, the following functions are performed:

- a. An ARM signal is provided to the orbiter interface for the RSS ARM indicator light.
- b. Power is provided to the PIC for the built-in test circuits and to charge the capacitor bank.
- c. Power is supplied to the FIRE latching switch.

#### 8.3.2 RSS FIRE Sequence.

When the FIRE latching switch receives a FIRE command pulse from the RSS IRD, or from cross-strapping, the following functions are performed, provided the ARM latching switch has previously been powered:

- a. A  $30 \pm 10$  ms time delay circuit is initiated (this allows for all signal time delays, e.g., latch switch "set" time, etc., in the signal cross-strapping system).
- b. Following the time delay, the PIC is switched on and the capacitor bank is discharged into the NSD.

#### 8.4 RSD ASSEMBLY INTERFACES FUNCTIONS.

In addition to ordnance destruct action, the RSD also provides the following:

- a. ARM latching switch INHIBIT/RESET control.
- b. RSS power OFF/ON control.
- c. Power distribution to the IRDs.
- d. Processing of commands from the orbiter and GSE to ARM, or SAFE the S&A device.
- e. Routing of RSS measurements through the SRB MDM to the orbiter transmission system.

##### 8.4.1 Interface Between the GSE and the S&A Device.

The EWR document requires that the S&A device be armed prior to launch. The LPS/General Purpose Computer (GPC) will perform the arming function. The orbiter onboard GPC-MEC will return the S&A device to the SAFE position in the event of a prolonged vehicle "hold/scrub" during vehicle launch operations and during flight operations shortly before SRB separation. The action to return the S&A to SAFE, along with turning off the range safety power supplies, provides a redundant protection to the SRB retrieval crew.

##### 8.4.2 Inhibit/Reset.

The RSD implements the LPS controlled "inhibit/reset" signals, which protect the STS and its crew from inadvertent destruct during final launch countdown after the ordnance is connected and the S&A device is commanded into the ARM position.

##### 8.4.3 RSS Power Supply.

The SRB RSD assembly consists of two independent and physically isolated electrical subassemblies, Subsystem A and Subsystem B, which are identical except that Subsystem A contains the position control for the S&A device and a voltage regulator for the RSS battery power, while Subsystem B contains a filter for the recovery battery power.

Power for Subsystem A is routed through a voltage regulator to a three-amp power latching switch. The Subsystem A voltage regulator drops the open circuit voltage of the RSS silver-zinc battery to approximately 28 VDC under nominal loads. Recovery battery power to Subsystem B does not require regulation, but a transient suppression filter is used because of the long wire from the recovery battery to the RSS RSD. The power ON command is from the GSE via SRB MDM and the OFF command is from the OV MEC (commanded by LPS on ground). From the three-amp latch switch, the power is divided into the IRD and the one-amp ARM latching switch. From the one-amp ARM latching switch, which is activated by the ARM command, the power is divided into two legs; one arms the PIC and the other supplies the one-amp FIRE latching switch. The RSD acts as the control center for the ARM and FIRE commands and provides for interconnecting (cross-strapping) the SRB RSS as previously described.

##### 8.4.4 S&A Device ARM & SAFE.

The S&A device is controlled exclusively from Subsystem A of the RSD. The S&A provides for mechanical interruption of the explosive chain. The device can be controlled electrically to interrupt the explosive train (SAFED), or ensure a propagation path (ARMED) between the NSDs and the destruct charge. The device has a cylindrical element with through holes that align with each NSD port and the corresponding Confined Detonating Fuse (CDF) assembly mounting port. There are two NSDs, two through-holes, and two CDF assembly ports for complete redundancy. To change from

either fixed state, the cylindrical element (rotor) is rotated by issuing the command (SAFE or ARM) that applies 28 volt solenoids to the toroidal motor. Rotation is 90° clockwise or counter clockwise. Through-holes are filled with pyrotechnic pellets to allow propagation of the explosive train.

Power for the device is supplied by the 28-volt regulated output of RSS System "A". RSS power ON is not required for S&A device operation. The S&A device is armed when the RSD receives an S&A ARM command from the GSE via the SRB MDM. The command closes a three-amp switch within the distributor, resulting in power to the ARM input of the S&A device. The safe logic for the S&A device requires two simultaneous SAFE commands that are hardwired from the orbiter MEC to the distributor. The commands close two non-latching switches in series, resulting in power to the SAFE input of the S&A device. The position indication (SAFED or ARMED) of the S&A device is routed directly to the SRB MDM and does not interface with the distributor.

After live ordnance is connected (CDF outputs) on the launch vehicle, the S&A is maintained in the SAFE position for safety. The 45th Space Wing range requirements dictate that ordnance be armed at lift-off. The ARM command is sent by ground equipment at T-5 minutes in the countdown.

## 8.5 RSS GROUND TRANSMISSION.

In a normal destruct sequence the ETR ground transmitter would transmit the ARM command a minimum of four times. Following the last transmission, there would be a time delay of a minimum of one second for PIC capacitor bank charging. After the time delay, the ground transmitter would send the FIRE (destruct) command a minimum of four times.

## 8.6 RSS ORDNANCE SUBSYSTEM DESCRIPTION

### 8.6.1 SRB RSS Ordnance.

The SRB RSS ordnance train consists of two redundant NSDs, one S&A device, four CDF assemblies, two CDF Assembly bulkhead connectors, and an LSC assembly (see Figure 8-9 and 8-10). The NSDs fire into the S&A device; the explosive leads in the S&A device propagate the ordnance train to the CDF assemblies. The CDF assemblies initiate through the CDF Assembly bulkhead connectors to other CDF assemblies, which in turn detonate the LSC.

The LSC is mounted along approximately 70 percent of-the booster length in the cable tunnel. The LSC is shown in Figure 3-21. The 80 foot long LSC assembly is used to split the SRB case causing thrust termination. The destruct assembly consists of a combination of individual components: the forward, intermediate, and aft LSC subassemblies; the CDF assembly-to-LSC connector; and the LSC assembly-to-LSC assembly connectors. Six LSC subassemblies (one forward, four intermediate, and one aft) are used in the SRB destruct assembly. The explosive material used in the LSC is HMX with a density of 1,000 grains per foot.

## 8.7 RSS ACTIVATION SEQUENCE.

The present planning for launch countdown operations of the RSS involves the following:

- a. Final open-loop testing of the onboard equipment to show compatibility with the ETR ground transmission equipment at approximately T-6 1/2 days using a test code.
- b. Removal of the test code following the open-loop test and installation of the flight code (classified) into the IRDs.
- c. Performance of a closed-loop functional test after installation of the flight code.

The Air Force requirements state that a final functional test must be performed "within 60 minutes of launch." In order to provide for a short hold within the last 30 minutes of countdown, MSFC has scheduled the final testing to occur at T-45 minutes. The sequence for testing can be found in SE-019-090-2H, SRB Mission Events Timeline.

## 8.8 SOLID ROCKET BOOSTER TRACKING SYSTEM (SRBTS)

### 8.8.1 SRBTS Operational Description

The Solid Rocket Booster Tracking System (SRBTS) permits tracking of the relative location of each SRB during shuttle ascent. The SRBTS provides interim tracking of the SRBs from liftoff through acquisition of radar skin tracking by the Eastern Range (ER). From that point on till SRB separation, the SRBTS functions as a back-up to the skin tracking radar. The SRBTS receives and responds to ER-transmitted radar signals to provide tracking of both SRBs. Each C-band transponder is uniquely coded to allow separate identification of the left and right SRBs. The primary function of the SRBTS is to supplement the radar skin tracking data to determine the position of the SRBs relative to the acceptable operating limits of the Eastern Range. The Flight Control Officer (FCO) utilizes the SRBTS data to determine the necessity of flight termination.

The SRBTS is not required to be operational at liftoff (not an LCC) and is classified as a Criticality 3 system. The ER has the ability to conduct the launch with out SRBTS support, but must use a different set of guidelines then it would if the SRBTS were functioning.

### 8.8.2 SRBTS Components

The SRBTS consists of two C-band antennas, a power divider, a C-band transponder, and a C-band Controller (CBC) on each SRB.

#### 8.8.2.1 C-band Antenna

The C-band Antenna is a commercial off the shelf C-band, optical quartz loaded, cavity backed helix antenna. Two antennae are flush mounted 180° apart in each SRB and are the receiving and radiating element during interrogation and response with the ground tracking station.

#### 8.8.2.2 C-band Power Divider

The C-band Power Divider is a commercial off the shelf unit that splits the signal supplied by the C-band Transponder to each of the two C-band Antennas. One power divider is used in each SRB.

#### 8.8.2.3 C-band Transponder

The C-band Transponder is provided by MSFC to decode the interrogation pulse that is issued by the ground tracking station. After decoding the interrogation pulse, the transponder replies by transmitting a response pulse that is used to calculate the SRB's location. Each transponder is tuned to listen for a different interrogation pulse sequence—one for the left and one for the right SRB. The ground tracking station determines the position of each SRB by the timing of the received response pulse relative to transmittal of the interrogation pulse sequence.

#### 8.8.2.4 C-band Controller (CBC)

The C-band Controller is a completely self-contained power and control source for the C-band Transponders. The C-band Controller power supply is an alkaline battery pack consisting of 48 “D” cell batteries that provides a nominal 31 volts (regulated) to the C-band Transponder. The CBC responds to three commands from the MDM: instrumentation on, power on, and power off.

#### 8.8.3 SRBTS Functional Description

The MDM in the forward IEA issues the commands for the SRBTS to the C-band Controller, which provides power to the C-band Transponder. The C-band Transponder begins listening for its unique interrogation pulse that is transmitted by the range radar received through the C-band Antenna. Once the correct pulse sequence has been decoded, the C-band Transponder transmits a response pulse, which is then radiated to the ground by the C-band Antenna. The ground then calculates the location of the SRBs to provide a redundant source of SRB tracking data for use by the FCO in determining the position of the SRBs relative to the safe operating limits of the Eastern Range.

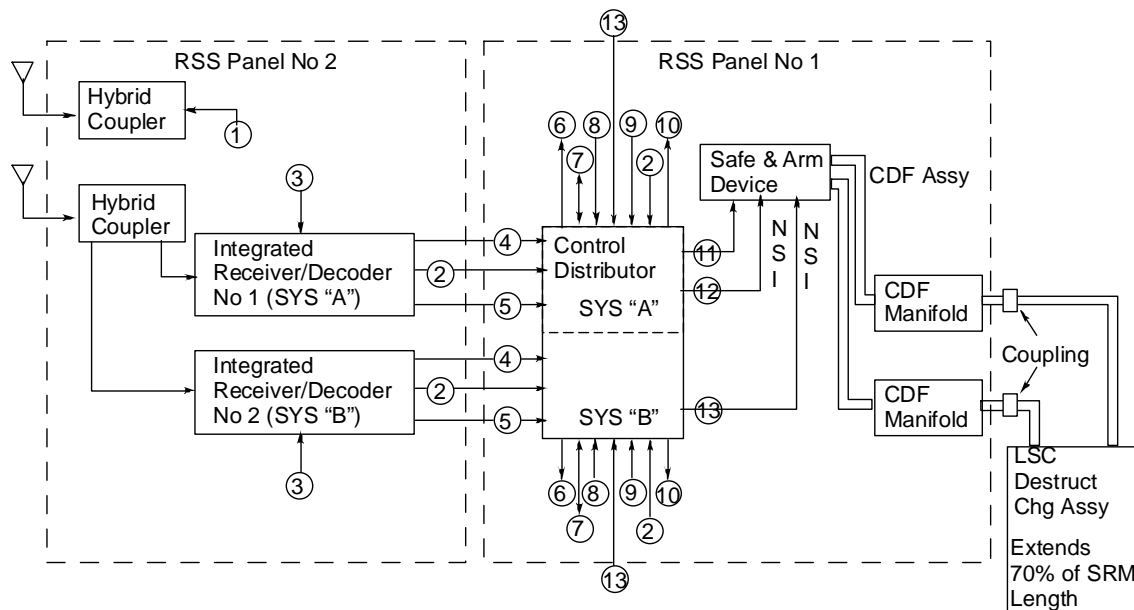

- |   |   |
|---|---|
| <ol style="list-style-type: none"> <li>1. GSE RF Input for Closed Loop Checkout</li> <li>2. Signal Strength Monitor to TM</li> <li>3. Code Insertion Connection</li> <li>4. "ARM" Command</li> <li>5. "FIRE" Command</li> <li>6. Monitor "Power On", "Inhibit", "Arm", "Fire", "PIC Arm", "RIG Fire", &amp; "S&amp;A Arm/Safe" Position</li> <li>7. Cross Strapping Between SRBs &amp; To ET</li> </ol> | <ol style="list-style-type: none"> <li>8. RS "Power Off", "Inhibit", And "S&amp;A Safe" Commands from Orbiter</li> <li>9. RS "Power Off", "Inhibit", And "S&amp;A Safe" Commands from SRB MDM</li> <li>10. "Abort Light (ARM)" Signal to Orbiter</li> <li>11. S&amp;A Control &amp; Monitoring Functions</li> <li>12. Initiation Destruct Signal</li> <li>13. RSS Battery used for SYS "A" &amp; "B"</li> </ol> |
|---|---|

Figure 8-1 SRB RSS Functional Diagram

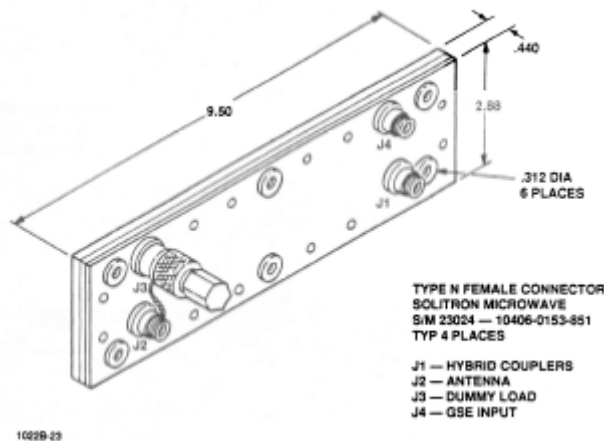

Figure 8-2. RSS Directional Coupler



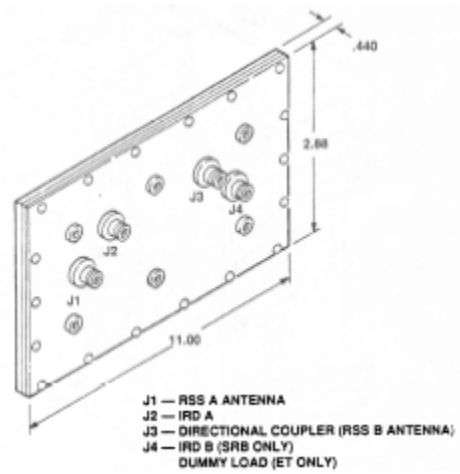

Figure 8-3. RSS Hybrid Coupler

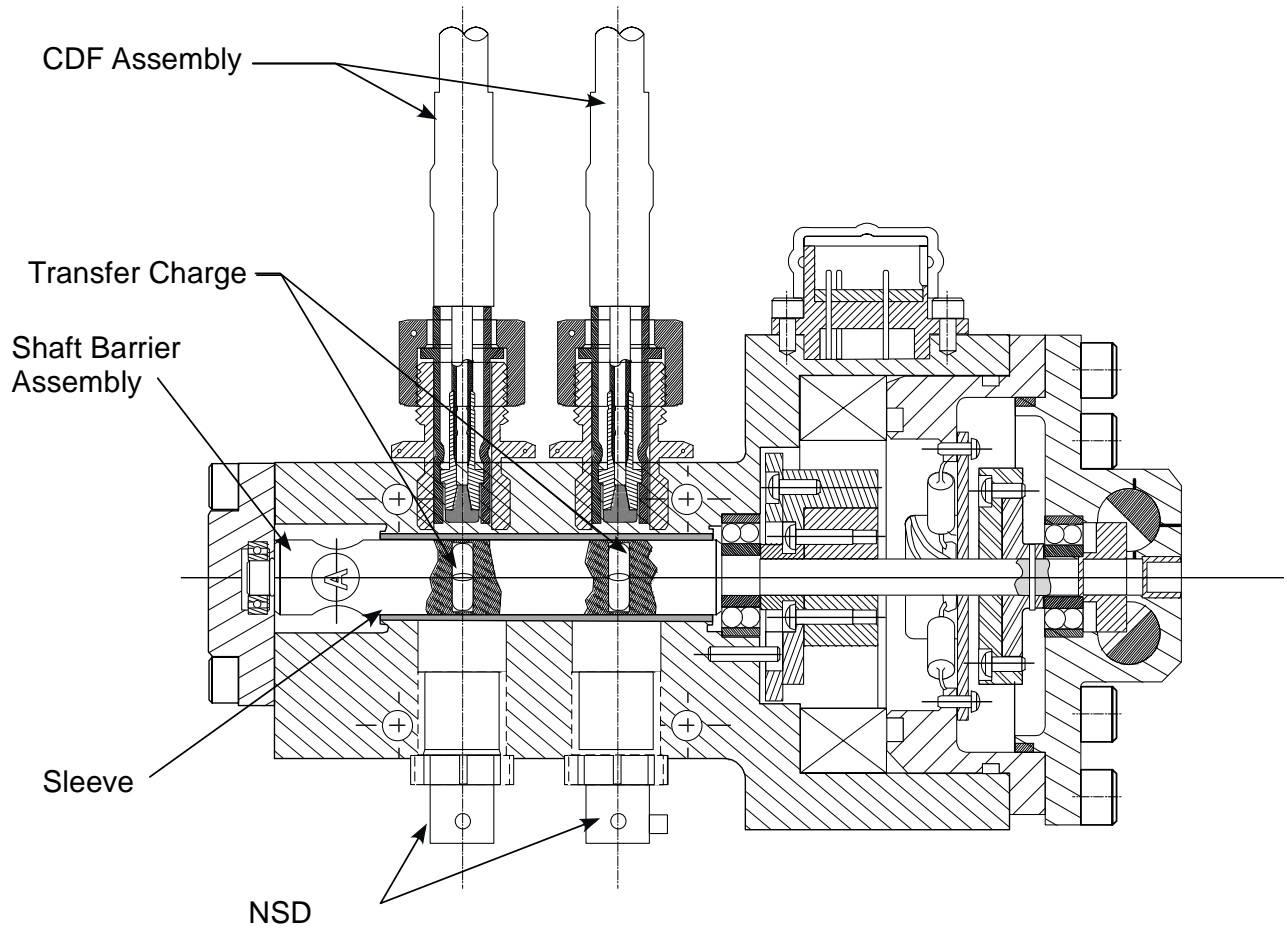

Figure 8-4. SRB Range Safe and Arm (S&A) Device Section View

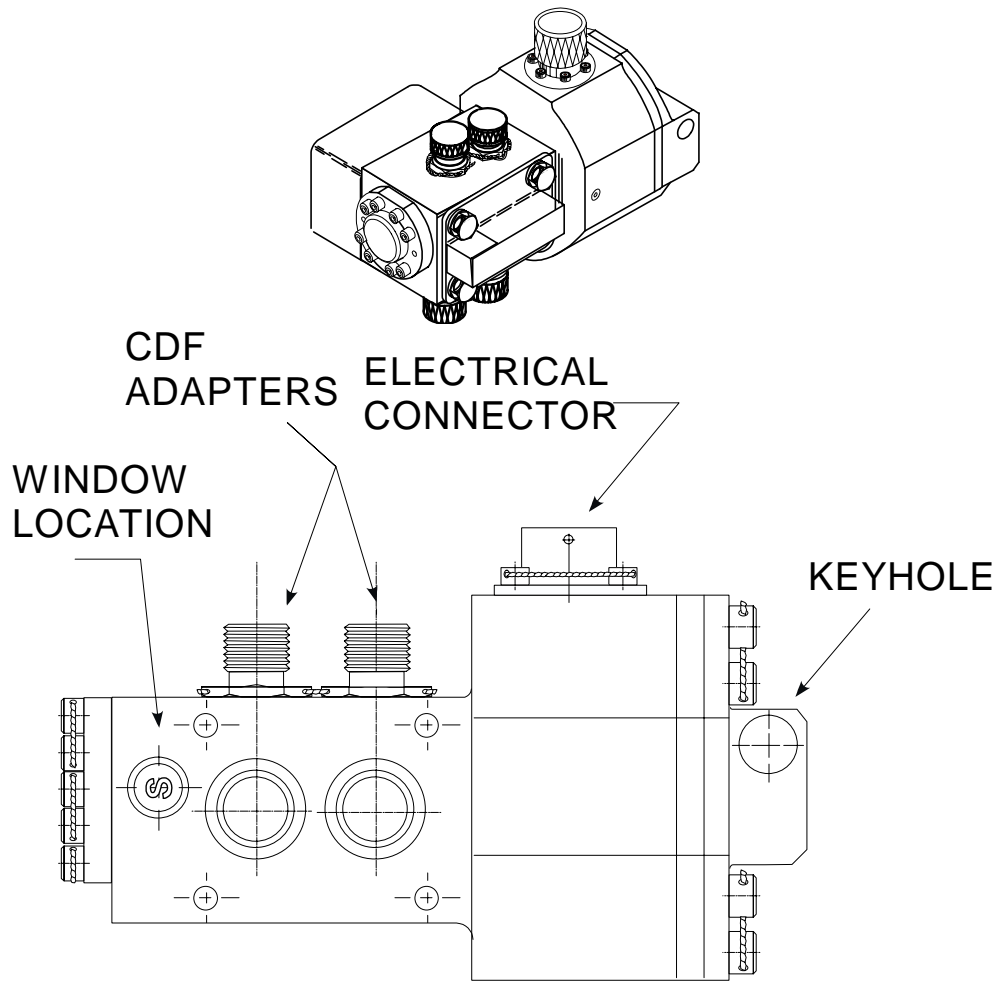
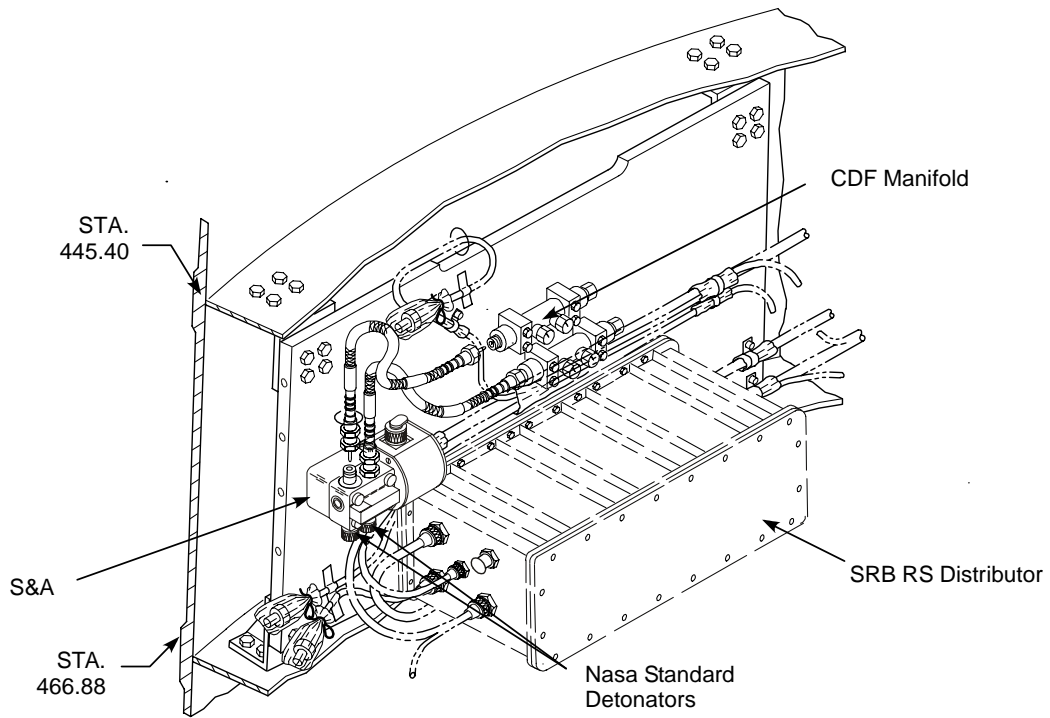

Figure 8-5 Safe and Arm Assembly for RSS



OVERALL VIEW OF RSS PANEL

Figure 8-6 Range Safety Panel No. 1

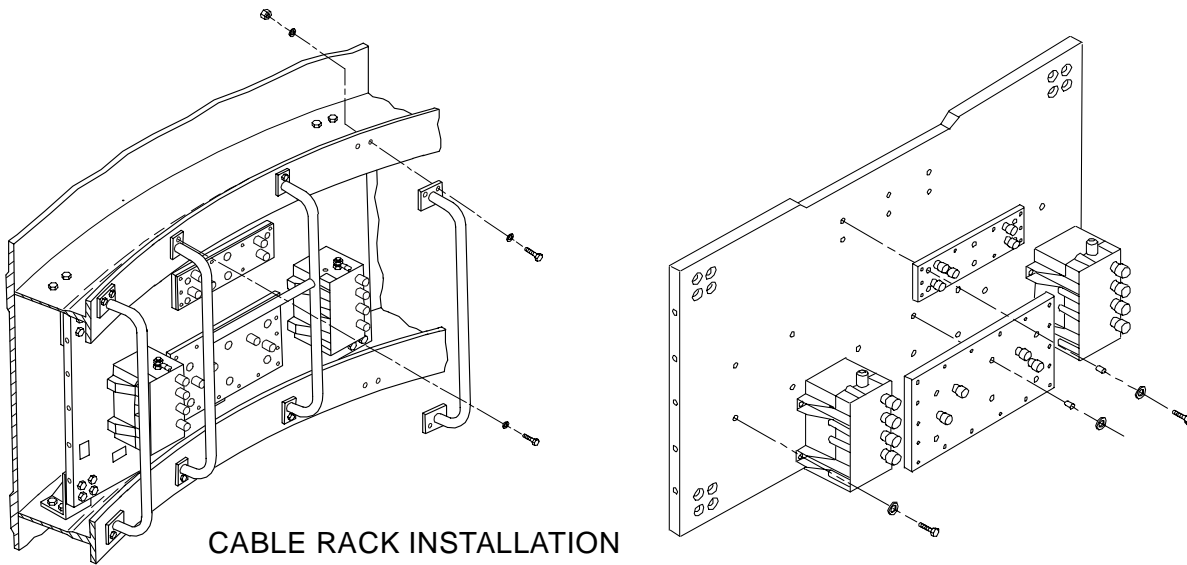

Figure 8-7 Range Safety Subsystem Panel No. 2 Forward Skirt

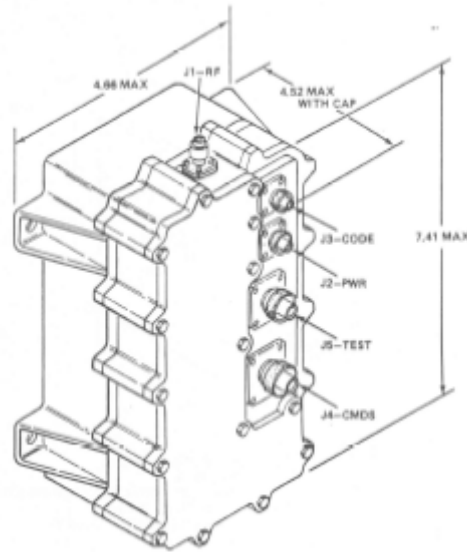

Figure 8-8. RSS Integrated Receiver/Decoder (IRD)

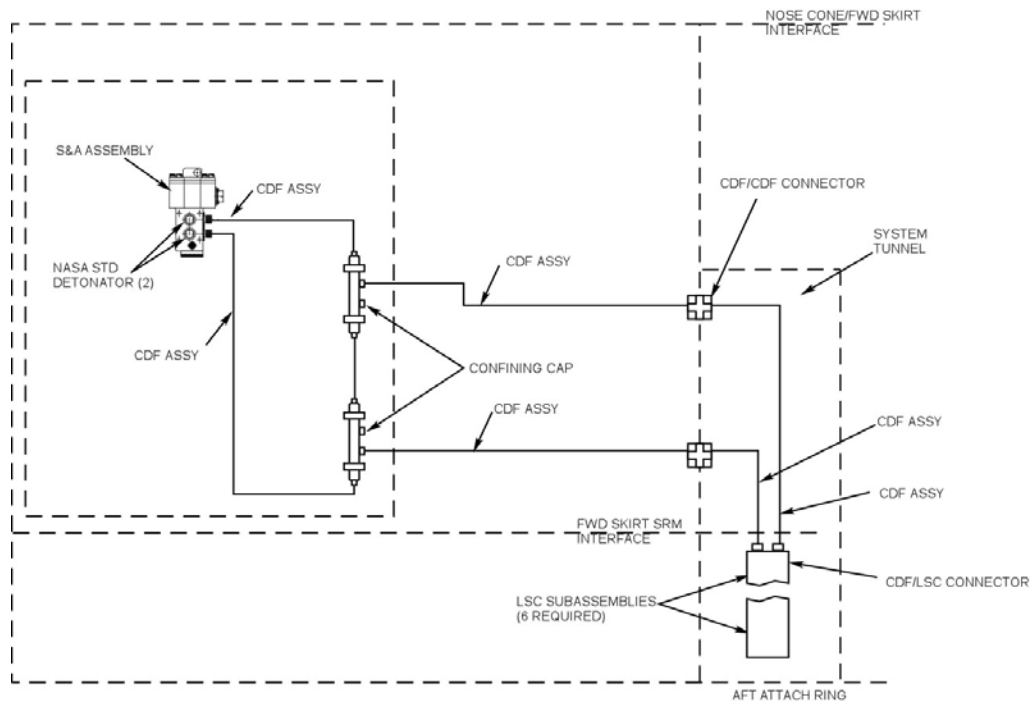

Figure 8-9. SRB RSS Ordnance Components

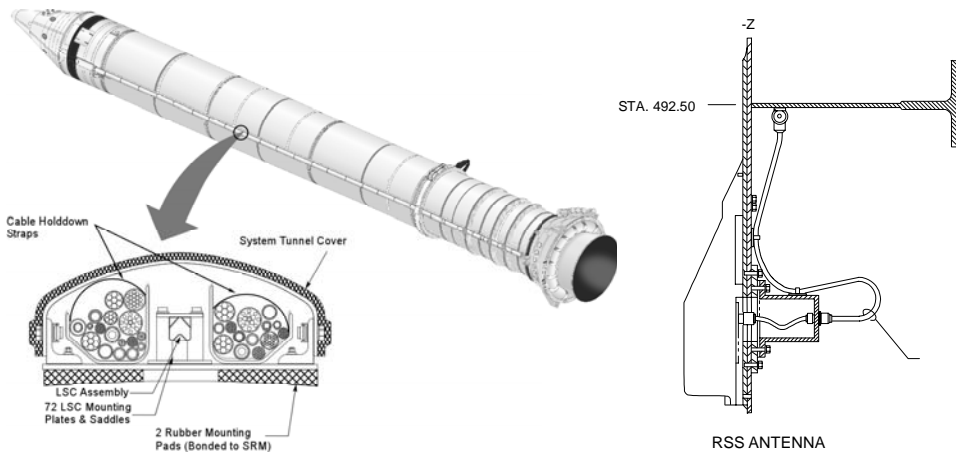

Figure 8-10. SRB Range Safety Command Destruct Subsystem

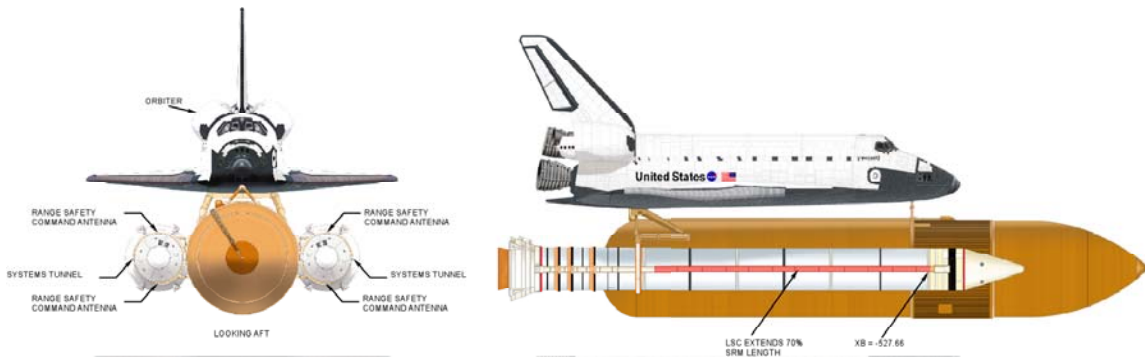

Figure 8-11. RSS Antenna Locations

## 9.0 SOLID ROCKET MOTOR

**NOTE:** The Reuseable Solid Rocket Motor (RSRM) information is being provided here for reference only. This information is not maintained by the SRB Project Office and may not reflect the current configuration. The portions that interface with SRB hardware will be maintained by the SRB office for completeness of information.

### 9.1 GENERAL.

Details on the SRM can be found in Section 1 of this document along with additional information in the attached appendices. The SRM is the primary propulsive element providing impulse and thrust vector control from ignition to SRB staging. The SRM subsystem consists of a weld-free, insulated and lined, segmented rocket motor case loaded with solid propellant; an ignition system that includes an electromechanical safe and arm device, initiators, and igniter chamber; an omni-directional movable nozzle, exit cone with a LSC for severance, an external systems tunnel; instrumentation; and required integration hardware. The major subassemblies are the forward motor segment, two interchangeable center motor segments, an aft motor segment, and an aft nozzle exit cone assembly with severance ordnance. This SRM envelope is shown in Figure 9-1. The SRM components and subsystems are physically interchangeable and are replaceable. Performance interchangeability of flight SRMs is maintained by propellant standardization and matching burning rates of motor segments. Maximum sea level thrust for each SRM is 3.07 million pounds.

### 9.2 SRM INTEGRATED IGNITION SEQUENCE OF OPERATION.

Operation of the SW ignition subsystem is predicated upon six distinct events in the space shuttle countdown sequence. These are as follows:

- a. Ignition and thrust buildup of the three SSMEs (0-6 seconds)
- b. SRB ignition ready indication (no inhibits),
- c. S&A device in the armed state,
- d. PICs in the armed state,
- e. Issuance of FIRE 1 command,
- f. Issuance of FIRE 2 command.

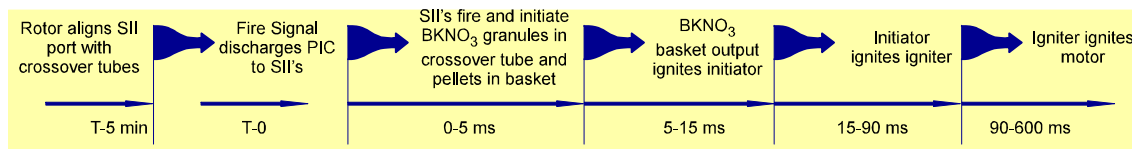

### IGNITION SEQUENCE

This assumes that the space shuttle countdown sequence has progressed to T-0 with no malfunction to preclude ignition and launch.

The SRBs are ignited at T-0 by the firing of redundant initiators through an S&A device into the SRM igniter. Actuation of the ignition sequence is by redundant commands originating in the OV GN&C computer. Initiation of these commands is dependent upon buildup of the OV SSMEs to 90 percent of rated thrust. The SSMEs are ignited at T-3.46 seconds. SRM ignition is commanded via hardware from the OV MECs to the forward IEA. Circuitry in the IEA executes PIC ARM FIRE 1 and FIRE 2 commands to two SRM NSIs, one per PIC, in each SRM ignition train. These commands are

simultaneously routed through the OV T-0 umbilicals to PICs provided by Kennedy Space Center (KSC) to effect SRB holddown release. A few milliseconds after SRM ignition, a command is issued to retract the OV T-0 umbilical.

Figure 9-2 shows the functional circuits involved in the SRM integrated ignition sequence of operation. The PICs used to fire the NSIs are located in the forward IEA and described in Section 4.0 of this document.

### 9.3 SRM CASE.

The SRM case functions as a pressure vessel in which thrust can be developed and as a structural frame through which flight loads are transmitted and reacted. The case is designed to withstand launch, ascent, reentry, and water impact loads and, after refurbishment and reloading, be reused 19 times. The case is composed of 11 segments, roll-formed of D6AC steel, machined and heat treated to withstand a maximum operating pressure of 1016 PSIA. The steel-case segments assembled in a single motor are a forward dome, six cylindrical segments, the ET attach segment, two stiffener segments, and an aft dome. The 11 case segments are preassembled into the forward, aft, and two center segments at the factory. The factory and field joints are assembled together using 177 MP35N cobalt alloy pins. See The pins protrude from the case surface and are held in place with a metal retainer band. The factory joints are externally sealed with a moisture seal vulcanized to the case wall. The field joints are externally sealed with a moisture seal containing redundant-heating coils and sensing devices to maintain the joint area at temperatures of 75°F or higher. The case segments are always assembled in the same positions with three removable tooling pins, positioned at approximately 120° around the case for case alignment and insertion of the 177 pins for assembly. Each factory joint is internally pressure sealed with dual V1115 Fluorocarbon O-rings and full internal insulation. The field joints are pressure sealed internally with bonded insulation and three O-rings. Each of the factory assembled segments is insulated and cast with propellant as a unit. The ignition system is attached to the forward segment by bolts and sealed with Gask-O-Seals. The nozzle is attached to the aft segment with 100 radial and 100 axial bolts, dual O-rings, a wiper O-ring, and bonded internal insulation. The assembled SRM case has a nominal overall length, boss to boss, of 1,388.567 inches. The outside diameter of the basic cylinder wall is 146.00 inches and a maximum nominal external dimension of 149.478 inches at the ET attach stub. The external surface of the assembled case is protected from general and stress corrosion by rust inhibitor paint.

The SRB hardware is connected to the RSRM casing via connections designated field joints (as they are connected pre-launch at the Hangar AF facility). These SRB joints are shown in Figure 9-3. The individual casting segments designated in Figure 9-1 are connected either via a factory joint or field joint connection. These connections are illustrated in Figure 9-4.

#### 9.3.1 Forward Segment.

The forward segment is swaged from a pancake billet of D6AC steel material. The use of a relatively flat 1.6:1 ellipse allows for a completely weld-free part. The dome thickness is tapered to maintain a constant stress. A short stub skirt with a male (tang) interface has been provided for attaching the SRB forward skirt assembly. A 21-inch inside diameter polar boss with bolted attachment provisions (forty 3/4-inch bolt holes) is at the apex of the forward dome for attachment of the ignition system. An aft facing male (tang) joint attaches this segment to the cylindrical case segment.

### 9.3.2 Cylindrical Segment.

The cylindrical segments are roll formed from rolled ring forgings. The basic cylindrical walls are roll formed "net", which requires no additional machining. Tang and clevis joints at either end are finish-machined after heat treatment in order to achieve the close tolerances required. The cylindrical segments are assembled to face aft in the forward segment assembly, and they have a nominal wall thickness of 0.506 inches with a tolerance of  $\pm 0.020$  inches. The cylindrical segments are assembled to face aft in the two center segments; they have a nominal wall thickness of 0.479 inches with a tolerance of  $\pm 0.020$  inches. The cylindrical segments in both the forward and two center motor segments have tangs with machined capture features to restrict rotation in the joints during motor pressurization.

### 9.3.3 SRB/ET Attachment Segment.

The attachment segment is roll-formed from a rolled ring forging. This segment contains two. attach flanges symmetrically located about Booster Station 1511 for attaching the SRB/ET aft attach ring, and has a forward-clevis joint and aft tang for attachment to the adjacent cylindrical and stiffener segments. The attachment stubs and clevis joints are machined after heat treatment.

### 9.3.4 Case Stiffener Segment.

The two case stiffener segments are roll-formed from rolled ring forgings. Each stiffener segment contains attach flanges for attaching two circumferential stiffener ring assemblies. The function of the stiffener rings is to prevent case buckling due to the cavity collapse loads during water impact. Two externally attached T-rings are assembled to the aft stiffener segment while the forward stiffener has a single T-ring assembled on the aft flange. The segments are identical and interchangeable.

### 9.3.5 Aft Dome.

The aft dome is forged into a partial hemispherical shape from a cylindrical rolled ring forging. A short stub skirt with a male tang interface is provided for attaching the SRM to the SRB aft skirt assembly. A polar boss provides for bolting the nozzle to the aft dome. One hundred 1 3/8-inch axial bolts and one hundred 7/8-inch radial bolts sealed with Stat-O-Seals attach the nozzle to the case. The nominal wall thickness of the hemispherical aft dome is 0.362 inches with a  $\pm 0.020$ -inch tolerance.

### 9.3.6 Stiffener Ring.

The three stiffener rings are made of 4340 steel and are fabricated in 120° sections, insulated and bolted together with splice plates to encircle the case. They are refurbished and reused up to 19 times.

## 9.4 PROPELLANT

### 9.4.1 Propellant Formulation.

The SRM propellant, TP-H1148N, is nearly identical to the proven formulations used in the Minuteman Stage I and Poseidon C-3 Stage I motors. Minor tailoring of the oxidizer and ferric oxide ratios achieved desired burning rates.

### 9.4.2 Composition

Basic composition properties of the RSRM propellants are given below in Table 9-1.



**TABLE 9-1 SRM Propellant Composition**

<u>Ingredient</u>	<u>Function</u>	Nominal Percent <u>Weight</u>
Aluminum Powder (Plus Ferric Oxide)	Fuel	16.0
Ammonium Perchlorate (AP)	Oxidizer	70.0
Ferric Oxide (Fe <sub>2</sub> O <sub>3</sub> )	Combustion Accelerator	**
Terpolymer, Liquid, Butadiene- Acrylic Acid-Acrylonitrile (HB Polymer) and Epoxy Resin, Liquid Bisphenol A/Epichlorohydrine Type	Binder	14.0
		100.0

\*\*The percent Fe<sub>2</sub>O<sub>3</sub> (combustion accelerator) is determined by standardization.

### 9.4.3 Properties

Basic burn properties and characteristics of the RSRM propellants are given below in Table 9-2.

**TABLE 9-2 SRM Propellant Burn Data**

Target Burn Rate	0.368 IPS--SRM-8 and Subs (TP-H1148N)
Density	0.064 lb/in <sup>3</sup>
Maximum Stress	110 lb/in <sup>2</sup>

The propellant is vacuum cast into the four SRM casting segments using 7,000 pound mixes. Bottom discharge casting is used to cast all segments. The forward segment requires 45 mixes, each center segment 41 mixes, and the aft segment 40 mixes.

### 9.4.4 Grain Design.

The quantity and design of the solid propellant in each segment of the SRM has been tailored to fulfill the performance requirements of the shuttle program. The propellant grain design for the forward portion of the forward segment is an eleven point star or deep fin configuration. The grain configuration in the aft portion of the forward segment, the two center segments-, and the aft segment are tapered, cylindrical perforated (CP) designs. The aft face of the forward segment, the aft ends of the two center segments, and the forward face of the aft segment are partially inhibited to a prescribed pattern, while the forward faces of the center segments are nearly fully inhibited to achieve the required thrust-time performance profile. The high thrust level required during the lift-off portion of the shuttle flight results from the extensive burning surface of the 11-point star configuration in the forward segment. After the initial portion of the flight, the thrust is reduced with the burnout of the starred section. After 52 seconds into the flight, thrust increases with burning of the CP configurations in all the segments. At approximately 80 seconds into flight, a thrust decay designed to limit vehicle acceleration reduces acceleration, and final tail-off is achieved by burning out the aft segments and slivers in the other segments.

## 9.5 INSULATION AND LINER

### 9.5.1 Insulation.

The insulation subsystem includes the chamber insulation, propellant stress relief flaps, and forward and aft facing inhibitors. The primary insulation material used in the chamber, relief flaps, and forward inhibitors is asbestos silica-filled nitrile butadiene rubber (NBR). Carbon fiber-filled EPDM insulation is used on the internal surfaces under the stress relief flaps and in the highly erosive aft dome areas. In both areas, the EPDM is backed by the NBR insulation. The castable inhibitor material on the forward and center segments is an asbestos-filled, carboxyl terminated polybutadiene (CTPB) polymer. The layers of uncured insulation raw materials are mechanically laid up under pressure and covered with a vacuum barrier. The insulation is cured (vulcanized) by pressure and heat, while a vacuum over the materials draws off the curing by-products. The vulcanization process cures the layers of raw materials into a single homogeneous mass, bonded to the case wall. The stress relief flaps are formed by sheets of inert materials laid up between the layers of insulation during vulcanization. The insulation in the segment to segment (field) joints is formed using mold tooling to provide the required configuration, and is autoclave cured at the same time as the other insulation.

During assembly, the insulation at the segment to segment joint is bonded together to provide the primary joint seal. A "J" flap is designed into the field -joint insulation to assure positive bondline pressure adhesion during motor operation. The factory joint external moisture seal, composed of EPDM, is bonded and vulcanized over the pin retainer bands on the outside of the case with the internal insulation. The aft facing inhibitors of the forward and center segments provide for controlled burning of the propellant to meet thrust performance requirements; they are formed by casting and toweling the CTPB over the partially cured propellant grains, and cured along with the propellant. The primary chamber insulation, propellant stress relief flaps, and forward facing web inhibitors provide thermal protection to the case and propellant grain and provide a chemically compatible stratum to which the liner/propellant is bonded. The propellant stress relief flaps at the aft end of each of the forward and center segments are provided to reduce insulation-liner bondline loads induced at propellant grain termination surfaces following propellant cure, cool down, handling, launch pressurization, and flight operations.

#### 9.5.1.1 Forward Casting Segment.

The formal segment insulation has been designed to protect the SRM casting segment during motor operation based on the 12-point star-CP grain configuration. After the propellant is burned, the case wall is protected by internal insulation, the thickness in a given area being determined by the temperatures, exposure time, and the velocity of the hot gases over that surface. In the forward segment, the thickness of the insulation varies from a thickness of 2.28 inches to a minimum thickness of 0.090 inches at the web burnout point.

#### 9.5.1.2 Center Casting Segments.

The center segments are identically insulated and interchangeable. There is a very short cast inhibitor at the aft end of these segments designed to provide extensive burn back of the propellant forward of the joint. The center segments have an insulation thickness ranging from 2.28 inches thick, to a minimum of 0.090 inches.

#### 9.5.1.3 Aft Casting Segment.

The insulation thickness of the aft segment varies from 5.096 inches at the nozzle/case interface to 0.380 inches at the web burnout point.

### 9.5.2 Liner.

The liner material provides a bond between the insulation and propellant in SRMs, and, therefore must be compatible with the selected insulation and propellant. The liner must have acceptable aging characteristics to maintain the insulation/liner/propellant bond throughout the service life of the SRM. The material selected for the liner is an asbestos-filled CTPB polymer (UF-2137).

## 9.6 NOZZLE.

The nozzle assembly is a convergent-divergent moveable nozzle design containing an aft pivot point flexible bearing as the gimbal mechanism. The nozzle provides a suitable interface for the retrieval system, attach point for the TVC actuators, attachment structure to mate with the motor aft closure, and an attachment part for the flexible heat shields. It contains an LSC for severance of the aft portion of the aft exit cone and a passive snubber assembly for cushioning water impact to prevent potential bearing damage. Figures 9-5 through 9-8 illustrate the major nozzle assemblies and components. The physical characteristics are listed on Table 9-3. The characteristics are compatible with the SRM performance requirements regarding thrust-time, movement constraints, geometric thrust vector, and dynamic thrust vector. The nozzle is a modular-type construction with parts grouped into assemblies to facilitate reuse and refurbishment of the flexible bearing nine times and the structural components for 19 times. In all the assemblies, redundant O-ring seals with leak test ports for seal testing, are provided. Internal nozzle component interfaces are sealed with extruded RTV sealant backfill.

**TABLE 9-3 SRM Nozzle Characteristics**

Nozzle Type	Contoured
Expansion Ratio	7.72:1
Exit Diameter (Inner) (Inches)	149.64
Exit Diameter- (Outer) (Inches)	151.95 (Excluding cork TPS)
Initial Throat Diameter (Inches)	53.860
Exit Area (Inner) (Feet <sup>2</sup> )	122.14
Nozzle Length Throat to Exit (Inches)	154.153
Nozzle Total Length	178.75
Submergence Ratio	19%
Initial L/RT	5.724
Exit Cone, Contoured	
Initial Angle (Degrees)	24.6
Turnback Angle (Degrees)	14.14
Exit Angle (Degrees)	10.46

### 9.6.1 Cowl Assembly.

The cowl assembly consists of an aluminum housing that attaches to the nose/inlet housing and the bearing assembly, and supports the OD ablative liner. The cowl assembly is vented internally with 36 vent holes, and insulated with silica cloth phenolic and DC 93-104 insulation. It supports the outer boot and boot assembly that provide the primary thermal protection for the bearing, while also providing for bearing flexion.

### 9.6.2 Nose/Inlet Assembly.

The nose/inlet assembly is the interface for the throat assembly and bearing forward end ring. It consists of an aluminum superstructure that is insulated and lined. The liner forms the gas flow contour

around the nose. The forward nose ring traps the aft ring against forward motion. The nose cap, in turn, traps the forward nose ring to provide positive redundant retention. The assembly is sealed at each end to preclude penetration of hot, high-pressure gas from the chamber into its void area.

#### 9.6.3 Throat/Inlet Assembly.

The throat/inlet assembly consists of a steel housing covered by carbon cloth phenolic ablative insulation and a glass cloth phenolic structural backing. The assembly interfaces with the nose/inlet, forward exit cone, and flex bearing assemblies. The shell is convergent to contain and support the throat and inlet rings, preclude downstream movement, and prevent ejection loads from reaching the exit cone

#### 9.6.4 Exit Cone Assembly, Forward.

This assembly consists of a full-length structural steel housing with carbon cloth phenolic insulation backed with glass cloth phenolic. At the forward end, externally, the snubber assembly prevents the excessive distention of the flexible bearing upon impact at splashdown.

#### 9.6.5 Exit Cone Assembly, Aft.

This assembly consists of an ablative inner insulation of carbon cloth phenolic, backed with a glass cloth phenolic over-wrap for structural integrity. The forward portion is covered with an aluminum outer shell that includes the aluminum compliance rings at its aft end. Actuator brackets attached to the compliance ring provide for motor thrust vectoring. An LSC located immediately aft of the compliance ring severs the nozzle aft exit cone after motor separation and burnout to reduce splashdown loads on the flex bearing.

#### 9.6.6 SRM Nozzle Plug.

The SRM nozzle plug is made of a high density polyurethane foam machined to a nominal thickness of 6.5 inches. It is coated forward and aft with RTV-21 silicone rubber insulation barrier. The outer plug/nozzle surface interface is protected with a polysulfide stiffener that also forms the bond to the forward exit cone of the nozzle immediately aft of the nozzle throat. The plug is assembled with the nozzle at the plant to provide for environmental protection during handling, transit, assembly, test, and SSME ignition. It is designed to be expelled and to disintegrate upon SRM ignition without damaging the nozzle or the MLP.

#### 9.6.7 Fixed Housing Assembly.

The fixed housing assembly consists of a conical steel shell insulated with carbon cloth phenolic and backed with glass cloth phenolic. It extends from the aft case boss to the flexible bearing aft end ring, and is the primary support structure for the nozzle assembly. It is subjected to both case pressure loads and axial compressive blowout loads. At the forward portion, the thickened insulation protects and retains the flexible boot assembly that is the primary protection of the flexible bearing from the hot chamber temperatures. The fixed housing is bolted to the aft dome boss with 100 axial bolts and 100 radial bolts. The radial bolts are sealed with Stat-O-Seals.

The carbon cloth phenolic is bonded to the aft dome EPDM and NBR insulation to form a primary seal. A wiper O-ring prevents adhesive migration into the joint sealed with redundant axial and radial O-rings. A leak test port provides for seal testing of the O-rings.

#### 9.6.8 Flexible Bearing Boot.

The flexible bearing boot is thermally protected by a flexible boot composed of seven plies of silica- asbestos filled NBR separated by carbon cloth and vented to provide flexion by 40 0.25-inch diameter vent holes through the six outer plies. The vents are behind the carbon cloth phenolic lip at the forward end of the fixed housing assembly that internally retains the boot. Externally, the boot is retained by the carbon cloth phenolic outer boot ring bonded to the cowl ring.

#### 9.6.9 Passive Snubber Assembly.

The snubber design consists of a 360° aluminum ring attached to the steel frame of the forward exit cone. Thirty-two snubber segments attached to it are positioned to conform to the aft ring of the flexible bearing with a gap of 0.250 to 0.270 inches between the snubber and the end ring. Positioning is accomplished with 32 aluminum axial and 32 radial shims. Upon water impact, the nozzle will be forced forward until the snubber segments impact upon the aft ring of the flex bearing.

### 9.7 FLEXIBLE BEARING ASSEMBLY.

The flexible bearing assembly provides an omni-directional nozzle movement capability. Protected primarily by the boot assembly, the bearing consists of a flexible core contained between two D6AC steel end rings. The core is a laminated structure consisting of 10 spherical D6AC steel shims and 11 natural rubber pads. End rings and shims absorb the applied loads while simultaneously controlling bearing motion during vectoring. The elastomeric pads transmit the loads while allowing relative motion to occur between the structural members. The end rings and internal bearing surfaces are protected with paint. Because the external surface is vented behind the boot, it is protected with a silicone elastomer bearing protector. The bearing is shown in Figure 9-6.

### 9.8 IGNITION SUBSYSTEM COMPONENTS.

The SRM ignition subsystem is mounted in the rocket motor case to the forward polar boss. It is 47.45 inches long and contains a total of 140 pounds of TPH1178 propellant in the initiator and igniter chambers. The ignition subsystem consists of the following:

- a. An S&A device which has a reusable electromechanical actuation and monitoring assembly containing an electric motor, a manual safing and locking mechanism, a visual position indicator, and booster barrier assembly containing the motor pressure seal, the safety barrier (rotated to ARM by the actuation and monitoring assembly), two initiators, a pyrotechnic booster charge, and an "armed" and "safe" indicator electrical switch.
- b. An igniter adapter that provides the mounting point between the other ignition subsystem components and the motor forward case segment.
- c. An igniter initiator, which is a small, multi-nozzle, steel, cased, solid propellant igniter containing a case bonded 30point star propellant grain.
- d. A rocket motor igniter which- is a single nozzle, steel-cased, internally and externally insulated solid propellant igniter containing a case bonded 40-point star propellant grain.

### 9.9 IGNITION DESIGN CHARACTERISTICS.

For the ignition sequence, the manual lock-pin must be removed from the S&A device an electrical arming signal to the S&A device causes the barrier rotor to move into the armed position. In the armed position, the SRM ignition initiators fire through a thin barrier seal into the pyrotechnic pellet charge, which is retained in the S&A device behind a perforated plate. The pellet charge ignites the TP=H1178 propellant of the igniter initiator, whose combustion products, in turn, ignite the propellant of the rocket motor igniter. The igniter initiator is threaded directly into the igniter adapter with thread

sealing compound, whereas the S&A device is bolted to the adapter with redundant, verifiable seals. Both the igniter initiator and adapter are insulated to provide protection from the heat of the propellant gases. The adapter is reusable and has heavy insulation to assure structural and dimensional integrity for 20 uses. The igniter initiator is not reusable. The D6AC steel igniter chamber is bolted to the adapter with redundant, verifiable seals and is insulated both externally and internally. The insulation is provided to assure a low temperature profile in the igniter chamber during motor operation and SRM descent, and is primarily required because of radiant heating and recirculation of motor gases through the large axial aft throat of the igniter.

The silica-phenolic throat insert has a thick profile to assure reusability of the igniter chamber without degradation because of excessive heating. The igniter adapter is bolted to the forward motor segment with redundant, verifiable seals.

#### 9.9.1 Igniter Adapter.

The igniter adapter is a machined D6AC steel forging providing the internal mounting surface for the igniter and the external mounting surface initiator for the S&A device to the forward rocket motor case boss. Forty 3/4-inch diameter high-strength steel bolts mount the adapter to the case. Gask-O-Seals provide for redundant pressure sealing between the adapter and the case, the igniter and adapter, and the adapter and the S&A device. Quarter inch tube ports provide for leak testing of each of the seals. Stat-O-Seals are used to seal the bolts on the inner bolt ring. Special bolt holes are provided in the adapter ring for mounting three 0-1000 PSI pressure transducers to measure chamber pressure. Internally, the adapter is insulated with 0.57 inches of silica-asbestos filled NBR.

#### 9.9.2 Igniter Initiator.

The igniter initiator is essentially a small six nozzle rocket motor ignited by the ignition of a basket of boron potassium nitrate pellets and granules in the S&A device. The initiator is made of AMS-4130 steel threading to the adapter. It is insulated with pre-molded silica-asbestos filled NBR bonded to the initiator and igniter insulation. The case is lined with OF-2137 liner and fueled with TP-H1178 propellant cast into the initiator and extruded into a 30-point star configuration to provide a large initial burning surface. TP-H1178 propellant differs from the TP-H1148N propellant used in the motor case in that it must burn faster and its large burning surface requires better propellant mechanical properties. To meet these requirements, the propellant uses a 3.0 percent iron oxide (Fe<sub>2</sub>O<sub>3</sub>) burn rate accelerator instead of the approximately 0.3 percent, used in the TP-H1148N propellant. It also contains smaller quantities of aluminum powder and the PBAN binder and ECA curing agents are increased from 14 percent to 18 percent. Spherical aluminum is also used to provide better mechanical properties. The throat inserts are made of carbon-phenolic. The initiator is not reused.

#### 9.9.3 Rocket Motor Igniter

The igniter chamber is made of D6AC steel and is reused 19 times. It is bolted to the adapter from outside the case with 32 3/4-inch diameter high-strength steel bolts. It is insulated internally with 0.35 to 0.76 inches of silica-asbestos filled NBR and externally with 0.93 inches of the same insulation. A single silica phenolic nozzle insert is bonded to the igniter chamber. The same liner and propellant that is used in the initiator is used in the igniter. It is cast into the chamber and extruded into a 40-point star configuration to provide an initial burning surface area of 6,600 square inches. Upon ignition at 60° F, the propellant grain produces a nominal operating pressure of 1,910 PSI and a nominal mass flow of 335 pounds per second for 0.350 seconds. The igniter provides for ignition of all the exposed propellant in the motor in less than 0.3 seconds, shuttle lift-off in 0.23 seconds and maximum operating pressure in 0.6 seconds. Figures 9-9 and 9-12 show the design of the ignition system and the

component connection flanges. Both the initiator and igniter proper are environmentally sealed with NBR membranes.

#### 9.9.4 S&A Device.

The device consists of an actuation and monitoring (A&M) assembly containing an electromotive drive element, electrical switch and manual safing features, and a pyrotechnic-booster-barrier (B-B) assembly containing a mechanical safe-arm barrier, the two SIIs, and the pyrotechnic booster assembly. The device has a leak test port for testing the redundant BB assembly shaft seals and the S&A initiator seals. Except for the pyrotechnic booster assembly, the device is designed for 19 reuses. Figure 9-13 shows the S&A components.

Figure 9-14 shows the S&A device, initiator and igniter, and forward RSRM casing as they would appear once integrated.

NOTE: The PICs that fire the SILs are located in the forward IEA and are described in Section 4.0 of this document.

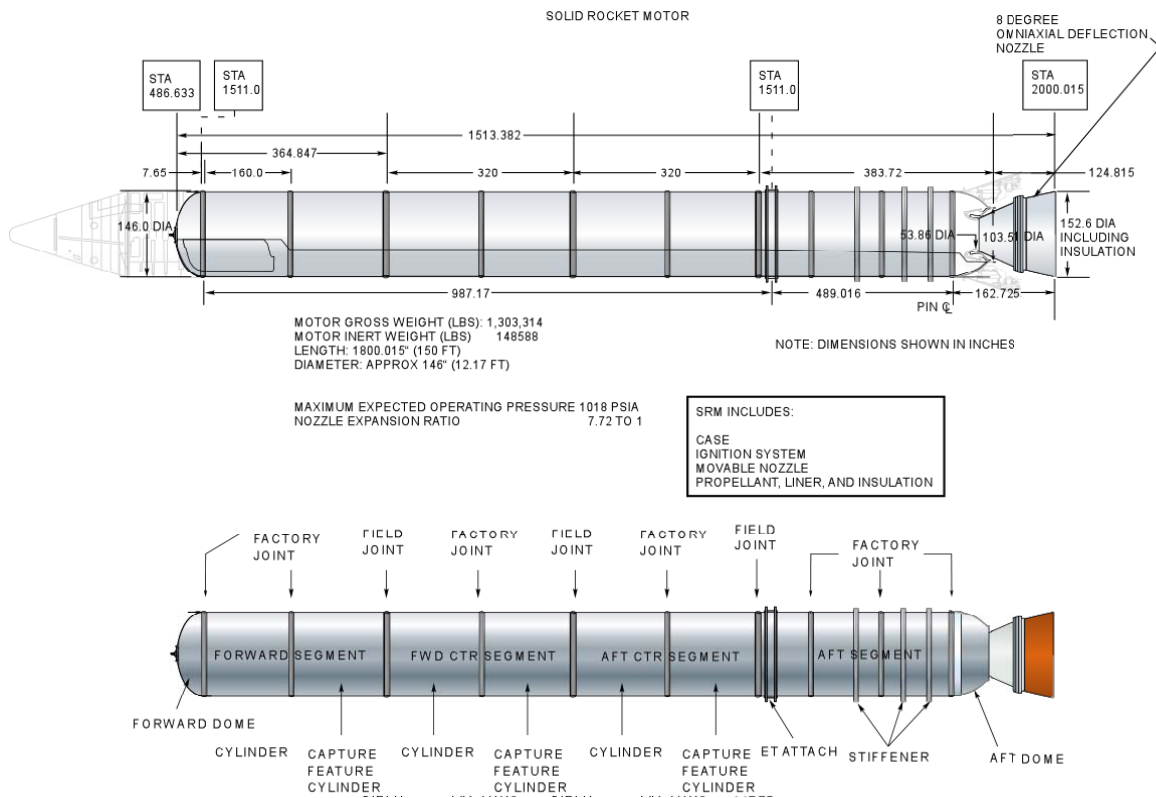

Figure 9-1. Solid Rocket Motor Configuration

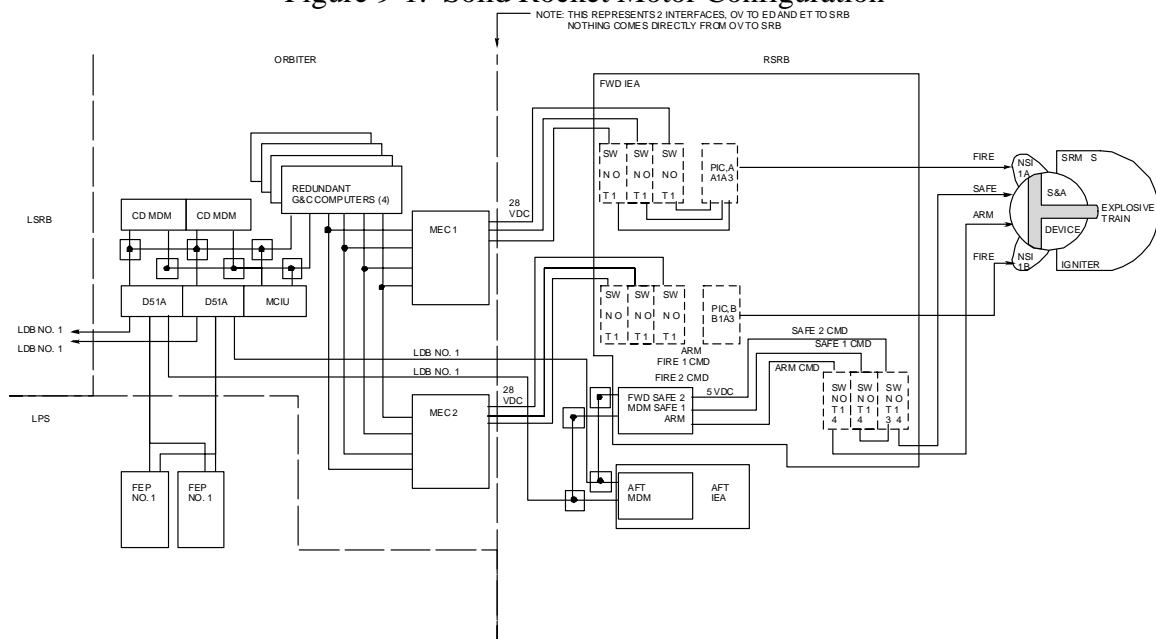
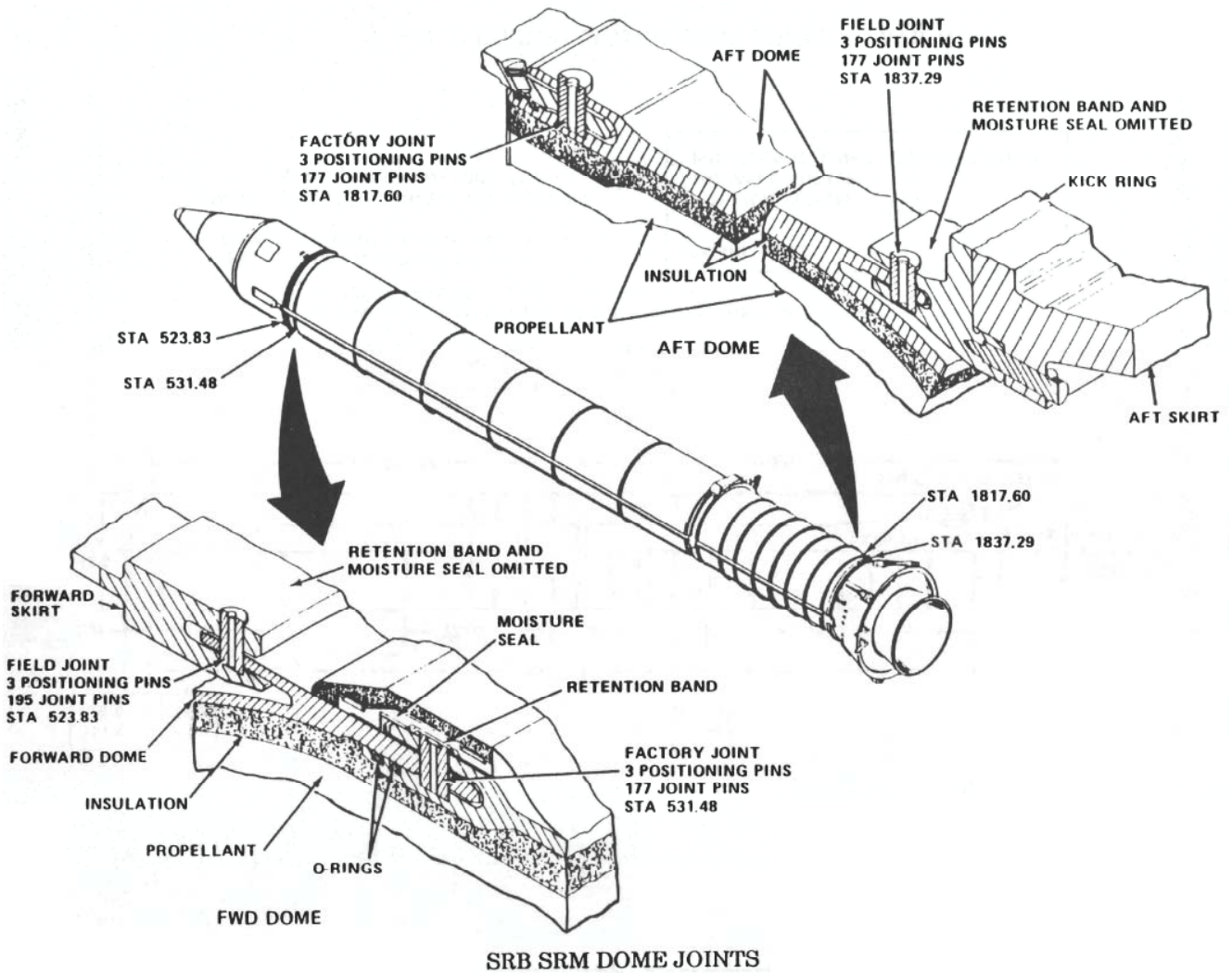

Figure 9-2. SRB Ignition Functional Circuits





SRB SRM DOME JOINTS

Figure 9-3a. SRM Dome Joints

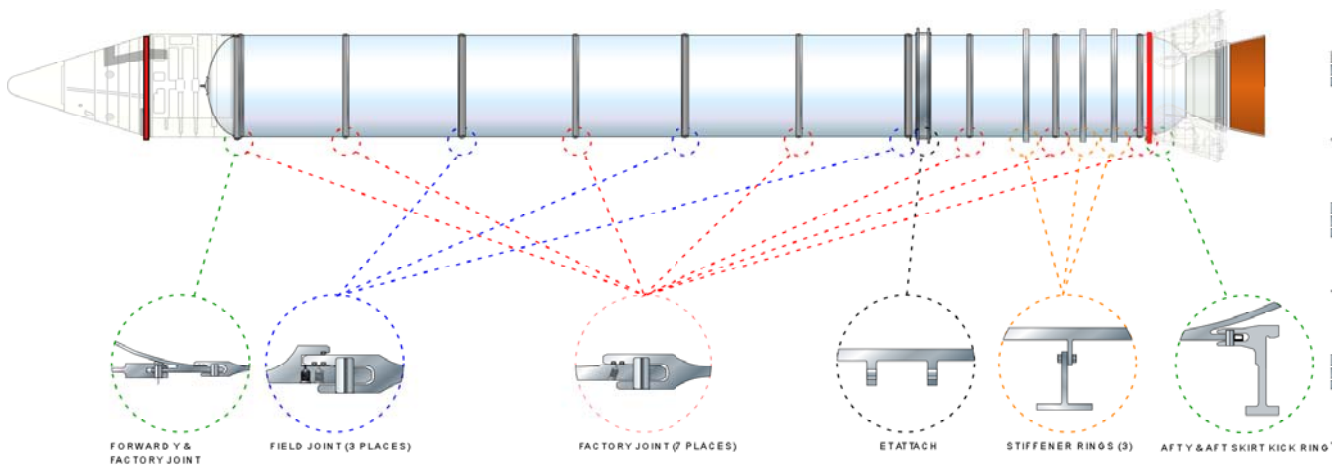

Figure 9-3b. SRB/SRM Joints

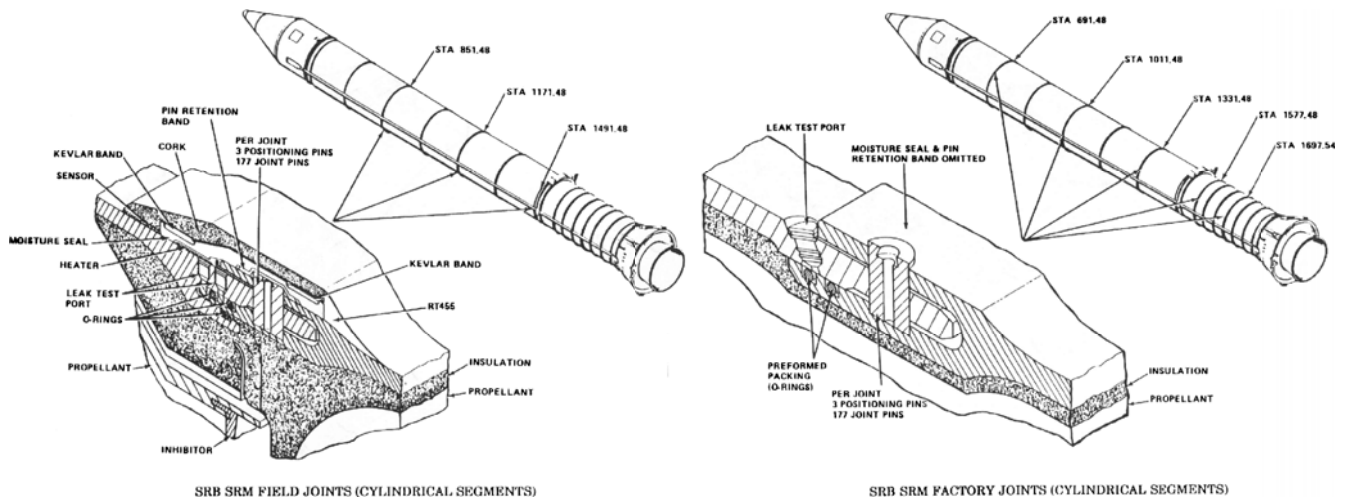

Figure 9-4a. SRM Field & Factory Joints

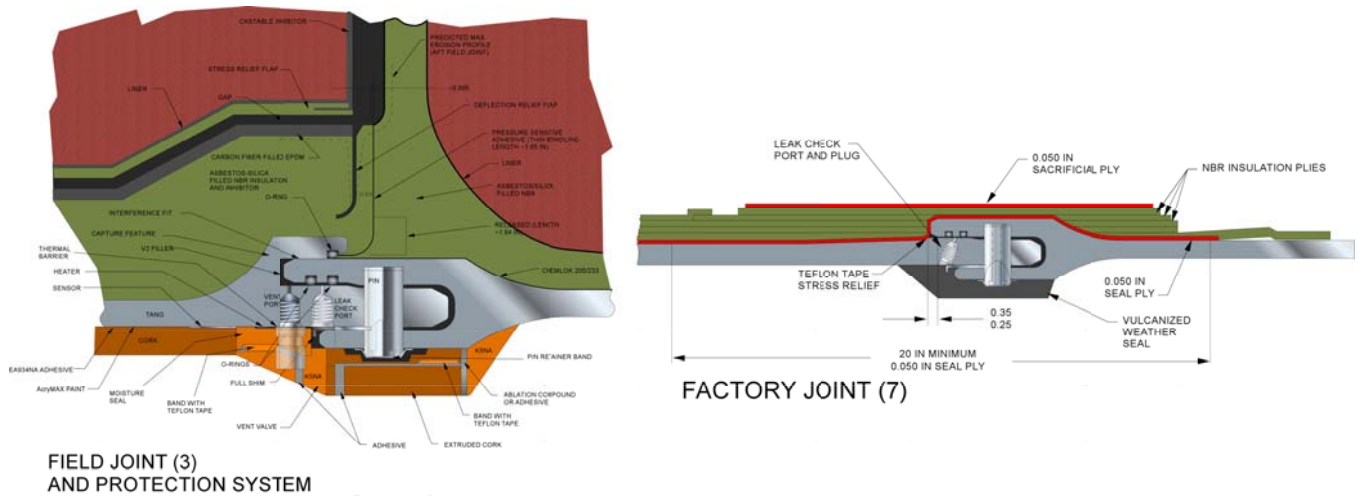

Figure 9-4b. SRM Field & Factory Joints Schematic



Figure 9-5. SRM Nozzle Assembly showing cutaway and Scale

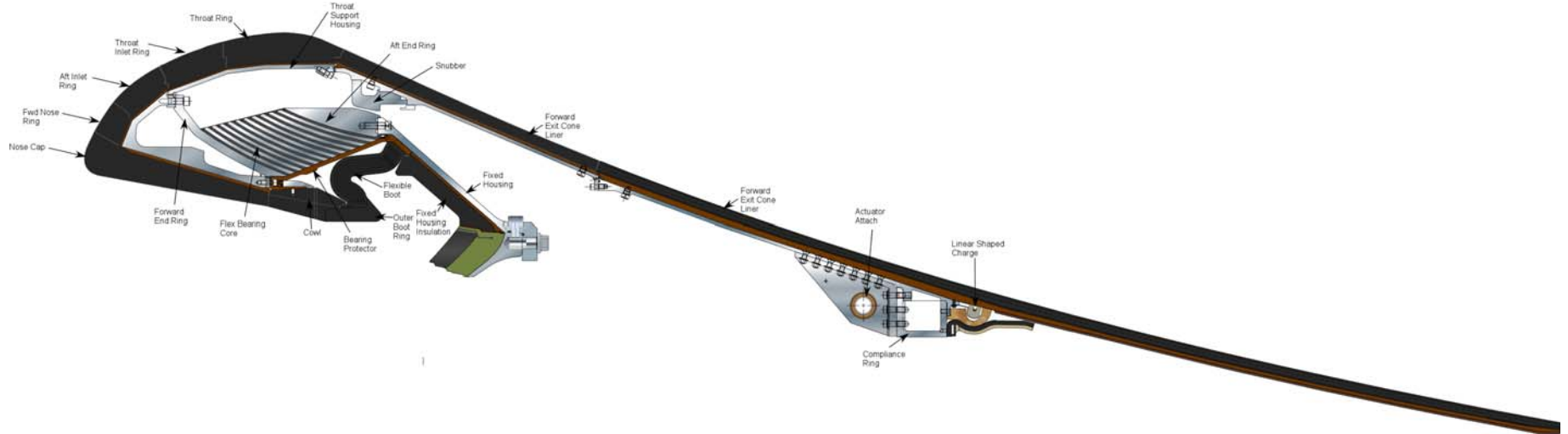

Figure 9-6 SRM Forward Nozzle and Aft Exit Cone Assemblies

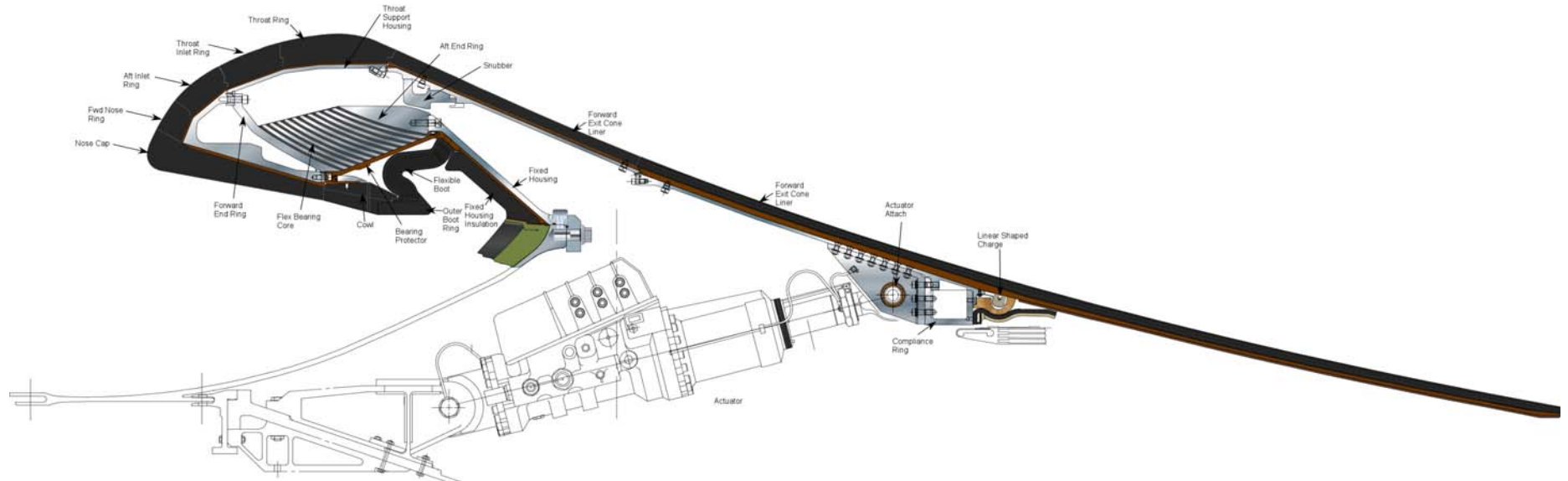

Figure 9-7a. SRM Nozzle Showing Actuator Connection and Aft Dome Joint

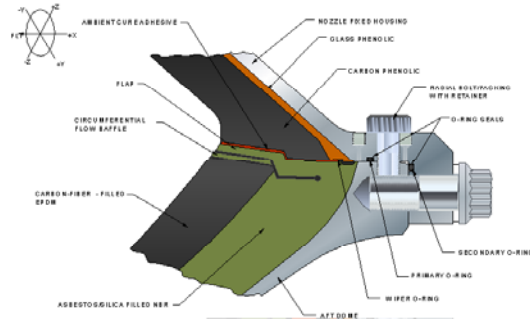

Figure 9-7b. SRM Nozzle Aft Dome Joint Schematic



Figure 9-8. SRM Nozzle Showing Five Joints

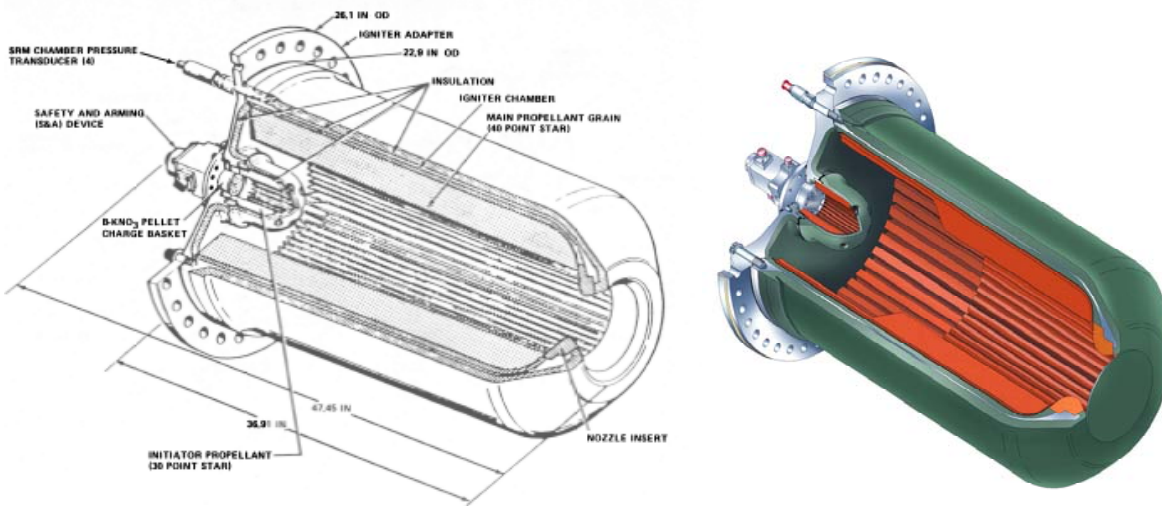
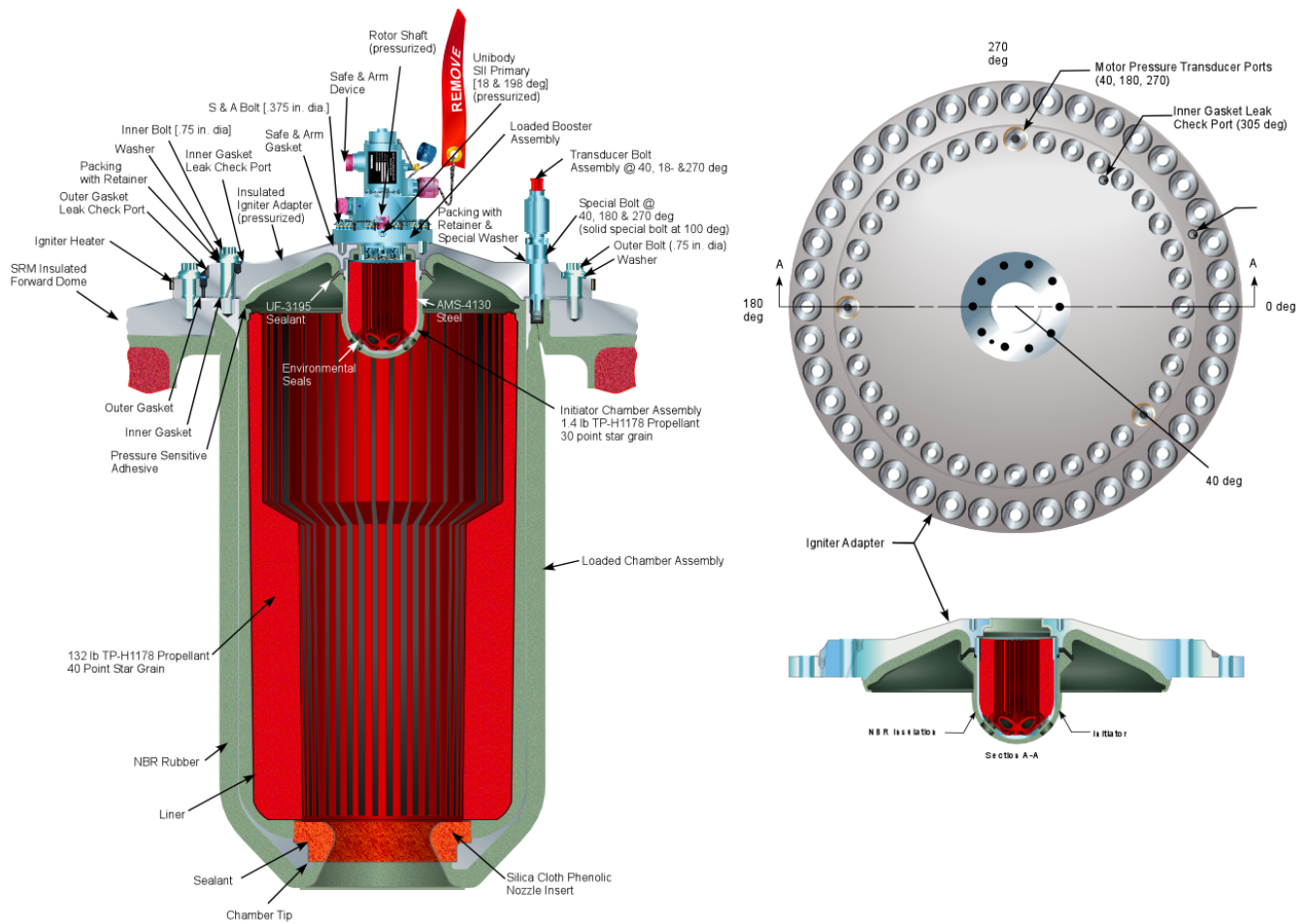

Figure 9-9. SRM Ignition Subsystem S&A Device Orthogonal View



IGNITION SYSTEM COMPONENTS

Figure 9-10. SRM Ignition Subsystem Igniter Device Showing Attach Flange and Details

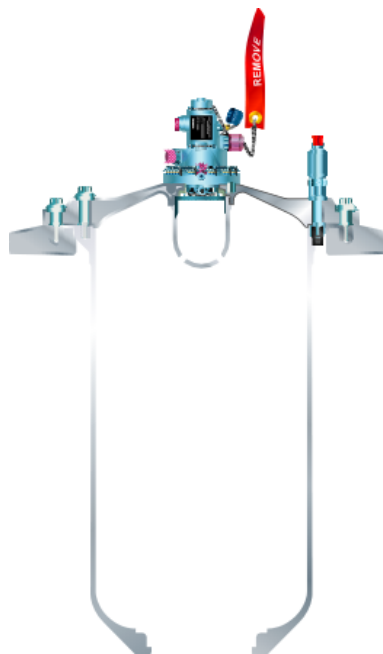

Figure 9-11. SRM Ignition S&A and Igniter Housing

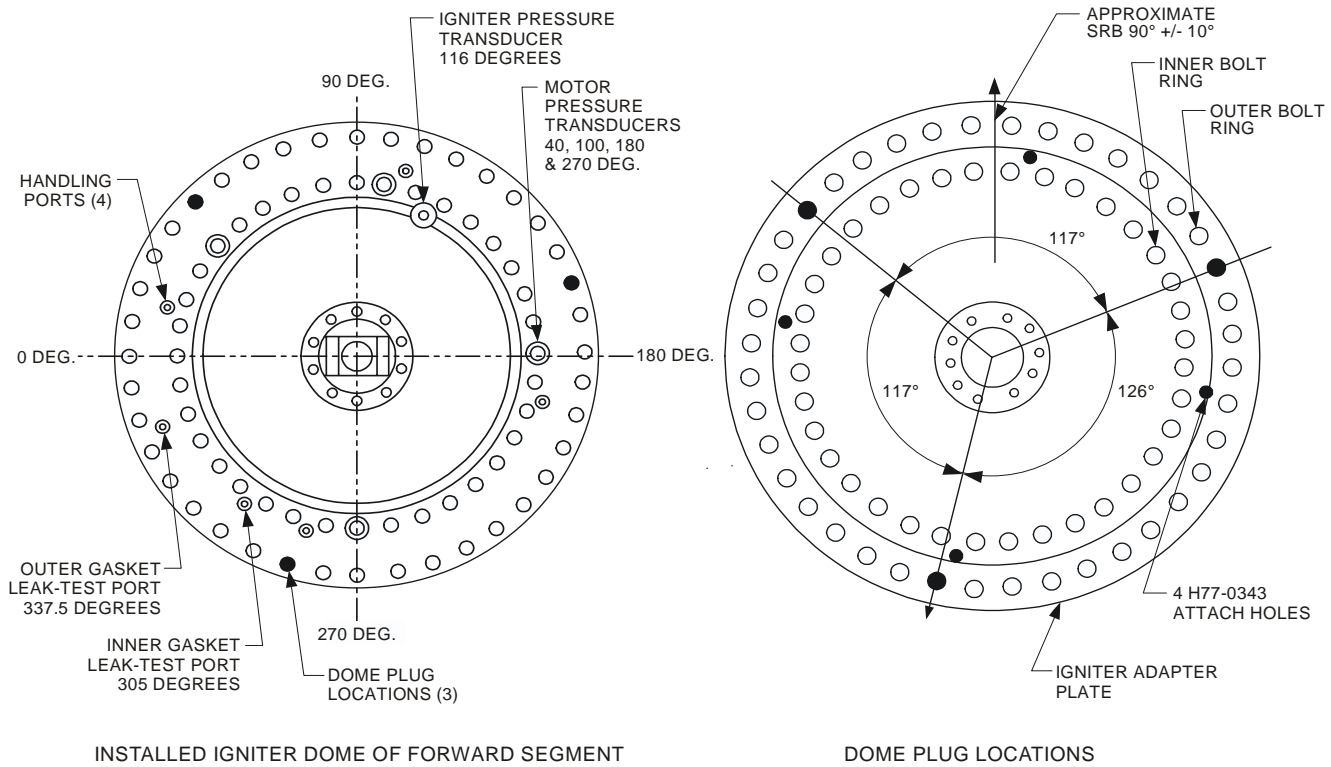

Figure 9-12. SRM Ignition S&A Device Attach Flange

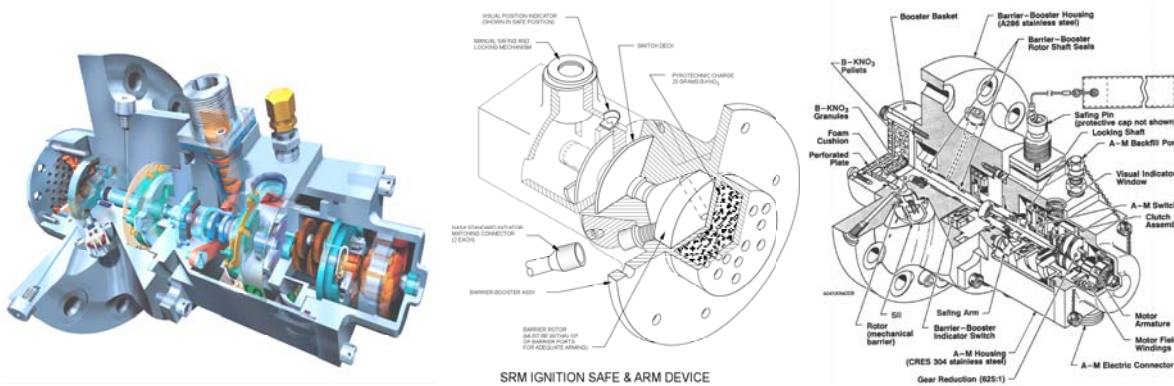

Figure 9-13. SRM Ignition S&A Device

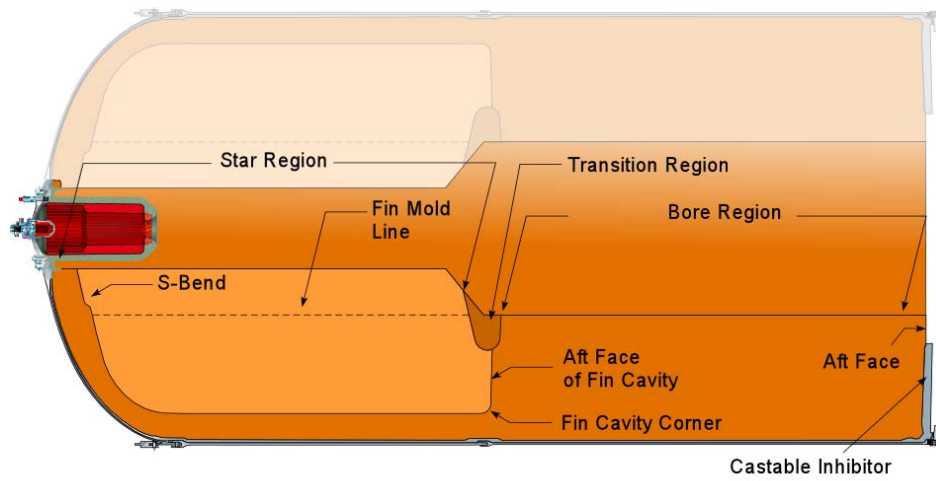

Figure 9-14. SRM Forward Case Cross Section Showing Star Pattern, S&A, And Igniter.